

Plug-in Signal Conditioners M-UNIT

PULSE ISOLATOR

(built-in excitation; rotary encoder use)

Functions & Features

- Galvanically isolating two pulse rate signals from a rotary encoder
- Various outputs (relay, open collector, voltage pulses and RS-422 line driver pulse)
- Different I/O specs can be specified
- Converting RS-422 line driver pulse input into an open collector pulse
- Excitation
- Isolation up to 2000 V AC
- High-density mounting

Typical Applications

- Isolating field pulse signals in order to reduce noises

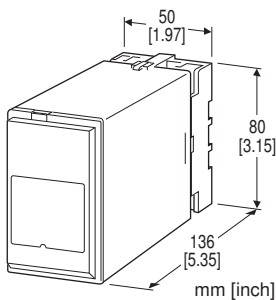

MODEL: RPPD-[1][2][3][4][5][6][7]-[8][9]

ORDERING INFORMATION

- Code number: RPPD-[1][2][3][4][5][6][7]-[8][9]
- Specify a code from below for each [1] through [9].
(e.g. RPPD-DD4AA3N-R/CE/Q)
- Output pulse width (e.g. 75 msec.)
- Use Ordering Information Sheet (No. ESU-1693). Default setting will be used if not otherwise specified. Refer to the factory default setting.
- Specify the specification for option code /Q
(e.g. /C01/S01)

[1] INPUT 1

- A: Dry contact
- B: Voltage pulse (Specify sensitivity)
- C: 5 V pulse (sensitivity 2 V)
- D: 12 V/24 V pulse (sensitivity 5 V)
- H: Two-wire current pulse
- J: RS-422 line driver pulse

[2] INPUT 2

Must be the same code as the one chosen for Input 1.

[3] EXCITATION

- 1: 5 V DC @ 120 mA
- 4: 12 V DC @ 60 mA
- 7: 24 V DC @ 25 mA

Excitation is not provided with input code J, but select code 1.

[4] OUTPUT 1

- A: Open collector (max. 100 kHz)
- M: 5 V pulse (max. 100 kHz)
- N: 12 V pulse (max. 100 kHz)
- P: 24 V pulse (max. frequency 50 kHz)
- H: High power photo MOSFET relay (max. 20 Hz)
(Option /CE Not available)
- J: RS-422 line driver pulse (max. 100 kHz)
- () = Max. frequency

[5] OUTPUT 2

- A: Open collector (max. frequency 100 kHz)
- M: 5 V pulse (max. frequency 100 kHz)
- N: 12 V pulse (max. frequency 100 kHz)
- P: 24 V pulse (max. frequency 50 kHz)
- J: RS-422 line driver pulse (max. 100 kHz)
- The max. frequency is in parentheses.

OUTPUT COMBINATIONS

The table below shows the selectable type of Output 1 for each Output 2 type.

With the Output 2 other than code A, the Output 1 must be the same type.

| OUTPUT2 | OUTPUT1 |
|---------|---------------|
| A | A, M, N, P, H |
| M | M |
| N | N |
| P | P |
| J | J |

[6] OUTPUT PULSE WIDTH

- 1: Equal to the input
- 3: One-shot output (std. pulse width 50 msec.)
(Specify when optional pulse width is required.)

[7] OUTPUT LOGIC (both Output 1 & 2)

- N: The same as the input
- R: Inverted

[8] POWER INPUT

AC Power

K: 85 - 132 V AC

(Operational voltage range 85 - 132 V, 47 - 66 Hz)

(CE not available)

DC Power

S: 12 V DC

(Operational voltage range 12 V \pm 10 %, ripple 10 %p-p max.)

(Option /CE Not available)

R: 24 V DC

(Operational voltage range 24 V \pm 10 %, ripple 10 %p-p max.)

V: 48 V DC

(Operational voltage range 48 V \pm 10 % , ripple 10 % p-p max.)

(CE not available)

P: 110 V DC

(Operational voltage range 85 - 150 V, ripple 10 %p-p max.)

(CE not available)

[9] OPTIONS (multiple selections)

Standards & Approvals

blank: Without CE

/CE: CE marking

Other Options

blank: none

/Q: Option other than the above (specify the specification)

SPECIFICATIONS OF OPTION: Q (multiple selections)

COATING (For the detail, refer to our web site.)

/C01: Silicone coating

/C02: Polyurethane coating

/C03: Rubber coating

TERMINAL SCREW MATERIAL

/S01: Stainless steel

FACTORY DEFAULT SETTING

■ SETTINGS FOR PULSE INPUT

INPUT 1, 2

• Dry Contact

| | |
|-------------------------|-----------------------|
| Input | Semiconductor contact |
| Filter | No filter |
| Detecting level 1 - 8 V | 2 V |
| Hysteresis 0 - 5 V | 0.5 V |

• Voltage pulse

| | |
|--------------------------|-----------------|
| Input waveform | Square wave |
| Input coupling | DC |
| Input amplitude | 0.5 - 50 Vp-p |
| Input offset | \leq 50 V |
| Filter | No filter |
| Detecting level 0 - 15 V | Adjusted to 1/2 |
| Hysteresis 0 - 5 V | 0.5 V |

• 5 V voltage pulse

| | |
|--------|-----------|
| Filter | No filter |
|--------|-----------|

• 12 V, 24 V voltage pulse

| | |
|--------|-----------|
| Filter | No filter |
|--------|-----------|

• 2-wire current pulse

| | |
|-------------------------|-----------|
| ON current (H) 0-25 mA | 14.5 mA |
| OFF current (L) 0-25 mA | 9.5 mA |
| Filter | No filter |

■ SETTINGS FOR PULSE OUTPUT

INPUT 1, 2

| | |
|--------------------|----------|
| Output pulse width | 50 msec. |
|--------------------|----------|

GENERAL SPECIFICATIONS

Construction: Plug-in

Connection: M3.5 screw terminals

Screw terminal: Chromated steel (standard) or stainless steel

Housing material: Flame-resistant resin (black)

Isolation: Input 1 or input 2 or sensor exc. to output 1 or output 2 to power

DIP SW1 & SW2: Used for input spec. setting

Input monitor LED

PL1: Red LED blinks according to input 1.

PL2: Red LED blinks according to input 2.

Excitation adjustment: 5 - 24 V DC

Input pulse sensing: DC coupled standard or AC coupled

Sensitivity adjustments: V_H pot. for Hi level; V_L pot. for Lo level

INPUT SPECIFICATIONS

Excitation: Shortcircuit protection; approx. 440 mA at shortcircuit

Pulse width time requirement: $\geq 5 \mu\text{sec}$.

The detecting levels shown below are default value. Refer to the manual for adjustment.

■ Dry Contact

Max. frequency: 100 kHz

Detecting Conditions

Exc. code: 1

Sensing: 5 V DC / 0.5 mA

Detecting level:

OFF: $\geq 2.25 \text{ V} / \geq 8.2 \text{ k}\Omega$

ON: $\leq 1.75 \text{ V} / \leq 5.3 \text{ k}\Omega$

Exc. code: 4

Sensing: 12 V DC / 1.2 mA

Detecting level:

OFF: $\geq 2.25 \text{ V} / \geq 2.3 \text{ k}\Omega$

ON: $\leq 1.75 \text{ V} / \leq 1.7 \text{ k}\Omega$

Exc. code: 7

Sensing: 16 V DC / 2.4 mA

Detecting level:

OFF: $\geq 2.25 \text{ V} / \geq 1 \text{ k}\Omega$

ON: $\leq 1.75 \text{ V} / \leq 0.8 \text{ k}\Omega$

Sensing voltage means the excitation supply to the sensor and the current value indicates that at shortcircuit.

Detecting level means the threshold used to determine ON or OFF status of the pulses and the resistance values indicated that of the sensor.

■ Voltage Pulse

Maximum frequency: 100 kHz

• **Customised pulse:** Specify DC offset and amplitude.

Waveform: Square or sine

Input impedance: $\geq 10 \text{ k}\Omega$

Input amplitude: 0.5 - 50 Vp-p

Max. voltage between input terminals: 50 V

• **5 V, 12 V, 24 V Pulse**

Waveform: Square or sine

Input impedance: $\geq 10 \text{ k}\Omega$

Detecting level

5 V Pulse: $V_H \geq 2.25 \text{ V}, V_L \leq 1.75 \text{ V}$

12 V / 24 V Pulse: $V_H \geq 5.25 \text{ V}, V_L \leq 4.75 \text{ V}$

($V_H - V_L \geq 500 \text{ mV}$)

■ Two-wire Current Pulse

Max. frequency: 100 kHz

Input resistance: receiving resistor 100 Ω

Input range: 0 - 25 mA

Hi/Lo level: $\leq 9.5 \text{ mA}$ for Lo, $\geq 14.5 \text{ mA}$ for Hi

■ RS-422 Line Driver Pulse

Maximum frequency: 100 kHz

Receiver: Conforms to RS-422

(No receiving resistor incorporated)

■ Voltage pulse waveform

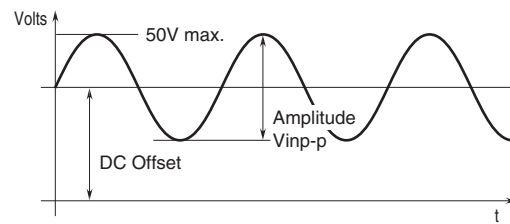

■ Voltage pulse (example)

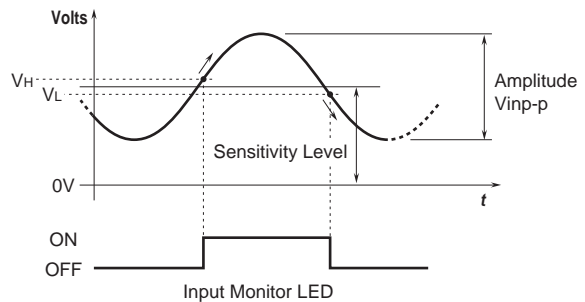

■ Dry contact (example)

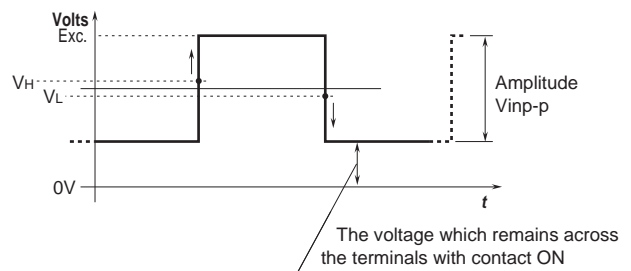

OUTPUT SPECIFICATIONS

■ High Power Photo MOSFET Relay

Maximum frequency: 20 Hz

• **Rise time:** 5 msec.

• **Sink time:** 3 msec.

Rating: 120 V AC or 120 V DC @ 200 mA (resistive load)

On resistance: 3 Ω

■ Open Collector

Maximum frequency: 100 kHz

50 V DC @ 50 mA (resistive load)

Saturation voltage: 0.5 V DC

■ **Voltage Pulse:** Rating (5, 12 or 24 V) $\pm 10 \%$

Maximum frequency: 100 kHz (50 kHz for 24 V)

Load resistance: $\geq 1.2 \text{ k}\Omega$

Low level: $\leq 0.5 \text{ V}$

■ **RS-422 Line Driver Pulse:** Conforms to RS-422

Output current: $\pm 20 \text{ mA}$

OUTPUT PULSE WIDTH

■ **Equal to the input:** Output waveforms have the same period and duty ratio as those of input waveforms (when DC coupled).

■ **One-shot Output**

This unit detects a pulse sink and outputs [input pulse width $\pm 20\%$]; 50 msec. standard

Note: 2 types of one-shot detection are available: pulse rise or sink. Refer to the table on the "Output Logic" section and specify when ordering.

Optional pulse width: 30 μ sec. - 300 msec.

INSTALLATION

Power consumption

- **AC:** Approx. 5.5 VA
- **DC:** Approx. 3.3 W (140 mA at 24 V)

Operating temperature: -5 to +60°C (23 to 140°F)

Operating humidity: 30 to 90 %RH (non-condensing)

Mounting: Surface or DIN rail

Weight: Approx. 135 - 200 g (0.30 - 0.44 lb)

PERFORMANCE

Response time

A delay of 4 μ sec. or below occurs when the pulse rises and falls.

- **Open collector:** The delay could be much longer for certain types of load.
- **High power photo MOSFET relay:** The output is delayed by 10 msec. at the rise, by 3 msec. at the fall.

Insulation resistance: $\geq 100\text{ M}\Omega$ with 500 V DC

Dielectric strength: 2000 V AC @1 minute (input to output to power to ground)

STANDARDS & APPROVALS

EU conformity:

EMC Directive

EMI EN 61000-6-4

EMS EN 61000-6-2

RoHS Directive

EXTERNAL VIEW

Note: This unit is factory calibrated according to the Ordering Information. If you need to change hardware setting, refer to the instruction manuals of the transmitter.

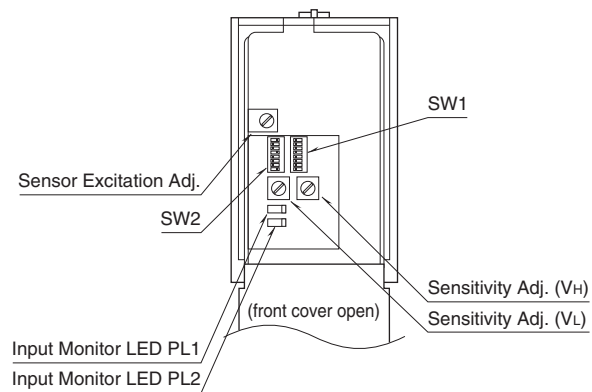

There is no need of hardware adjustment for RS-422 line driver pulse input. Unnecessary switches or LEDs are not provided.

OUTPUT LOGIC

Applicable for both Output 1 and 2.

| OUTPUT WAVEFORM | | INPUT WAVEFORM | VOLTAGE PULSE, 2-WIRE CURRENT PULSE or RS-422 LINE DRIVER PULSE | DRY CONTACT |
|--|--------------|--|---|-------------|
| | | | H L | OFF ON |
| VOLTAGE PULSE or RS-422 LINE DRIVER PULSE | Non Inverted | No pulse width conversion | | |
| | | One-shot, detecting input pulse rise | | |
| | | One-shot, detecting input pulse drop | | |
| | Inverted | No pulse width conversion | | |
| | | One-shot, detecting input pulse rise | | |
| | | One-shot, detecting input pulse drop | | |
| OPEN COLLECTOR or POWER PHOTO MOSFET RELAY | Non Inverted | No pulse width conversion | | |
| | | One-shot, detecting input pulse rise | | |
| | | One-shot, detecting input pulse drop | | |
| | Inverted | No pulse width conversion | | |
| | | One-shot, detecting input pulse rise | | |
| | | One-shot, detecting input pulse drop | | |

The pulse width in one-shot means the bold lined section of a pulse waveform.

*Pulse rise for RS-422 line driver pulse can not be detected.

EXTERNAL DIMENSIONS & TERMINAL ASSIGNMENTS unit: mm [inch]

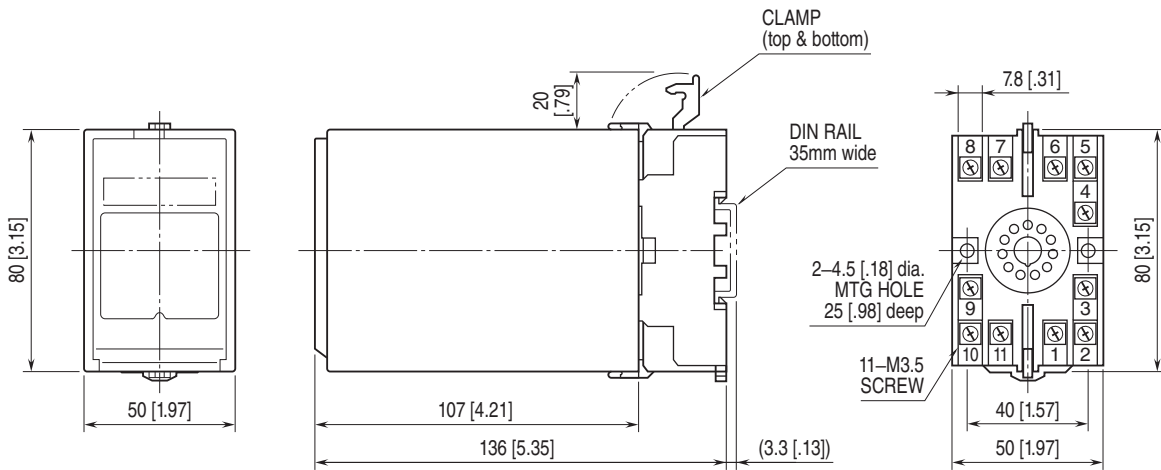

• When mounting, no extra space is needed between units.

SCHEMATIC CIRCUITRY & CONNECTION DIAGRAM

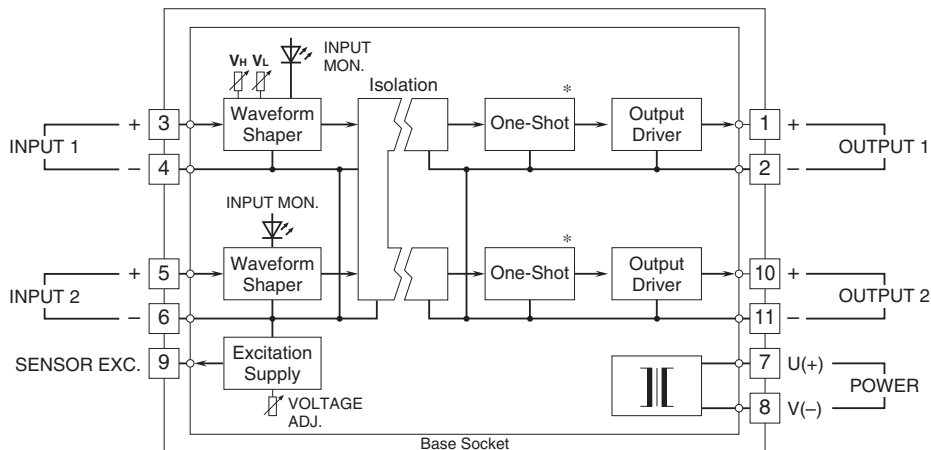

* Provided only when the one-shot output is specified.

Note 1: With 24V excitation and dry contact input, the voltage across the terminals 3 - 4, 5 - 6, divided in the waveform shaper, is of approx. 16V.

Note 2: Not negative common in case of RS-422 line driver pulse output or power photo MOSFET relay output.

Input Connection Examples

■ Dry Contact

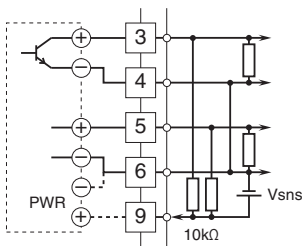

■ 2-Wire Current Pulse

• Built-in Excitation

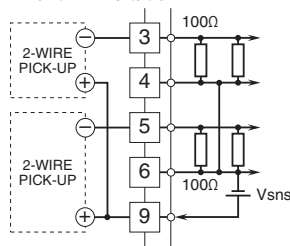

Output Connection Examples

■ Open Collector

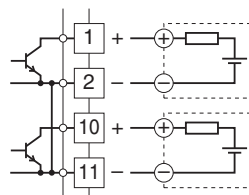

■ Voltage Pulse

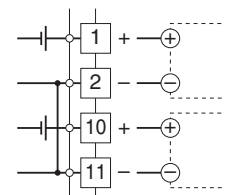

■ Voltage Pulse

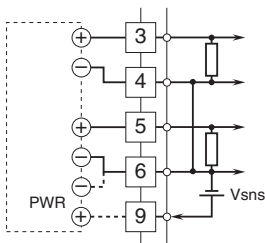

• External DC Supply

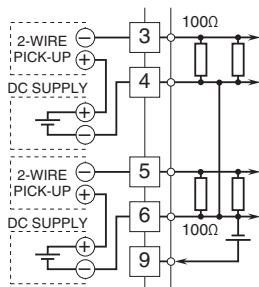

■ Power Photo MOSFET Relay

• AC Powered

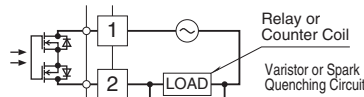

• DC Powered

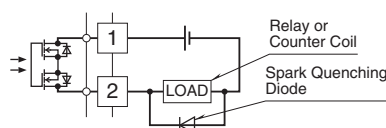

■ RS-422 Line Driver Pulse

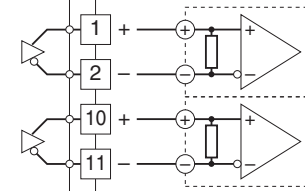

■ RS-422 LINE DRIVER PULSE INPUT

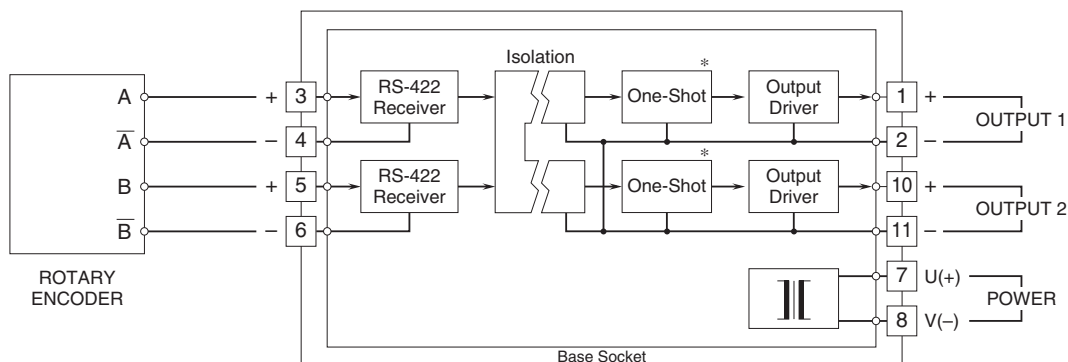

* Provided only when the one-shot output is specified.

Note 1: Sensor excitation not provided for RS-422 line driver pulse input.

Note 2: Not negative common in case of RS-422 line driver pulse output or power photo MOSFET relay output.



Specifications are subject to change without notice.