

## Remote I/O R1X Series

### THERMOCOUPLE & DC INPUT MODULE

(16 points; DeviceNet)

#### Functions & Features

- 16-point thermocouple or DC inputs
- DeviceNet interface

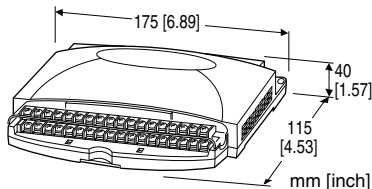

### MODEL: R1D-GH2T-[1][2]

#### ORDERING INFORMATION

- Code number: R1D-GH2T-[1][2]
- Specify a code from below for each of [1] and [2].  
(e.g. R1D-GH2T-M2/Q)
- Specify the specification for option code /Q  
(e.g. /C01)
  - Use Ordering Information Sheet (No. ESU-5956). Default setting will be used if not otherwise specified.

#### Factory default setting

Input type: DC Voltage  $\pm 5$  V  
Burnout protection: No burnout  
Cold junction compensation: No

### FIELD TERMINAL TYPE

T: M3 screw terminals

#### [1] POWER INPUT

AC Power

**M2:** 100 - 240 V AC (Operational voltage range 85 - 264 V, 47 - 66 Hz)

DC Power

**R:** 24 V DC

(Operational voltage range 24 V  $\pm 10$  %, ripple 10 %p-p max.)

#### [2] OPTIONS

blank: none

/Q: With options (specify the specification)

#### SPECIFICATIONS OF OPTION: Q

COATING (For the detail, refer to our web site.)

/C01: Silicone coating

/C02: Polyurethane coating

/C03: Rubber coating

#### RELATED PRODUCTS

- Resistor module (model: REM3-250)
- R1X configurator software (model: R1CON)
- EDS file

The EDS file and configurator software are downloadable at our web site.

A dedicated cable is required to connect the module to the PC. Please refer to the internet software download site or the users manual for the PC configurator for applicable cable types.

#### GENERAL SPECIFICATIONS

##### Connection

**Power input, DeviceNet:** Euro type connector terminal (applicable wire size: 0.2 to 2.5 mm<sup>2</sup> (AWG24 to 12), stripped length 7 mm)

**Input:** M3 screw terminals (torque 0.6 N·m)

**Configurator:** 2.5 dia. miniature jack; RS-232-C level

**Screw terminal:** Nickel-plated steel

**Housing material:** Flame-resistant resin (gray)

**Isolation:** Input to DeviceNet to power

**Power indicator:** Green LED turns on with power supplied.

#### DeviceNet COMMUNICATION

**Transmission cable:** Approved for DeviceNet

**Node address setting:** Rotary switch or software; 00 - 63

**Baud rate setting:** DIP switch or software

**MS (Module Status) indicator:** Bi-color (green/red)

LED indicates device status.

**NS (Network Status) indicator:** Bi-color (green/red)

LED indicates status of the communication link.

**Device Profile:** Generic Device

#### INPUT SPECIFICATIONS

##### ■ Thermocouple or DC input, 16 points

(Common negative for DC input)

• Measuring range  $\pm 20$  V,  $\pm 5$  V,  $\pm 1$  V: Atten. SW ON (3)

• Measuring range  $\pm 0.8$  V,  $\pm 0.2$  V,  $\pm 50$  mV,  $\pm 10$  mV: Atten. SW OFF (1)

**Input resistance:** 300 k $\Omega$

**Thermocouple types:** PR, K, E, J, T, B, R, S, C, N, U, L, P

**Sampling rate:** 150 millise./16 points

■ **A/D conversion output:** 16-bit signed binary (negative range represented by 2's complements)

Engineering unit value is converted into A/D conversion data as shown below.

**Input type & range: A/D data (decimal)**

- ±20 V: ±20000
- ±5 V: ±5000
- ±1 V: ±10000
- ±0.8 V: ±8000
- ±0.2 V: ±20000
- ±50 mV: ±5000
- ±10 mV: ±10000

Thermocouples: Temperature × 10

In order to change input type and range after shipment, the R1X configurator software (model: R1CON) is required.

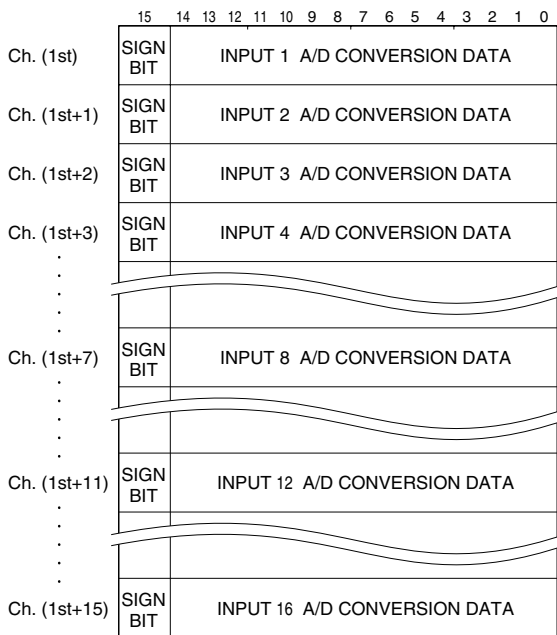

The R1D reserves 16 words at the Output Data Area (data sent from the R1D to the master) for the specified node address and sets the input data at this area. The Input Data Area (data sent to the R1D from the master) for the same node address is only reserved but unused.

## INSTALLATION

**Power consumption**

- AC: Approx. 6 VA
- DC: Approx. 2 W

**Supply voltage to network:** 11 - 25 V DC supplied through the network terminal block

**Supply current to network:** 50 mA max.

**Operating temperature:** -5 to +60°C (23 to 140°F)

**Operating humidity:** 30 to 90 %RH (non-condensing)

**Mounting:** Surface or DIN rail

**Weight:** 380 g (0.84 lb)

## PERFORMANCE (% of measuring range)

**Accuracy**

**DC input:** ±0.3 %

**Thermocouple input:** See the table on the end of this section.

**Cold junction compensation error:** ±3°C or ±5.4°F max. (at 20°C ±10°C or 68°F ±18°F)

**Temp. coefficient:** ±0.015 %/°C (±0.008 %/°F)

±0.05 %/°C (±0.03 %/°F) for 10 mV range and T/C B (RH)

**Insulation resistance:** ≥ 100 MΩ with 500 V DC

**Dielectric strength:** 1500 V AC @ 1 minute

(input to DeviceNet to power to FG)

**Thermocouple Accuracy**

T/C	USABLE RANGE (°C)	ACCURACY (%)	CONFORMANCE RANGE (°C)
(PR)	0 to 1770	±0.5	400 to 1770
K (CA)	-270 to +1370	±0.3	0 to 1370
E (CRC)	-270 to +1000	±0.7	0 to 1000
J (IC)	-210 to +1200	±0.7	0 to 1200
T (CC)	-270 to +400	±1.0	0 to 400
B (RH)	100 to 1820	±0.7	700 to 1820
R	-50 to +1760	±0.7	400 to 1760
S	-50 to +1760	±0.7	400 to 1760
C (WRe 5-26)	0 to 2320	±0.7	0 to 2320
N	-270 to +1300	±0.5	0 to 1300
U	-200 to +600	±0.5	0 to 600
L	-200 to +900	±0.3	0 to 900
P (Platinel II)	0 to 1395	±0.5	0 to 1395

T/C	USABLE RANGE (°F)	ACCURACY (%)	CONFORMANCE RANGE (°F)
(PR)	32 to 3218	±0.5	752 to 3218
K (CA)	-454 to +2498	±0.3	32 to 2498
E (CRC)	-454 to +1832	±0.7	32 to 1832
J (IC)	-346 to +2192	±0.7	32 to 2192
T (CC)	-454 to +752	±1.0	32 to 752
B (RH)	212 to 3308	±0.7	1292 to 3308
R	-58 to +3200	±0.7	752 to 3200
S	-58 to +3200	±0.7	752 to 3200
C (WRe 5-26)	32 to 4208	±0.7	32 to 4208
N	-454 to +2372	±0.5	32 to 2372
U	-328 to +1112	±0.5	32 to 1112
L	-328 to +1652	±0.3	32 to 1652
P (Platinel II)	32 to 1395	±0.5	32 to 1395

Note: CJC error is not included.

## EXTERNAL VIEW

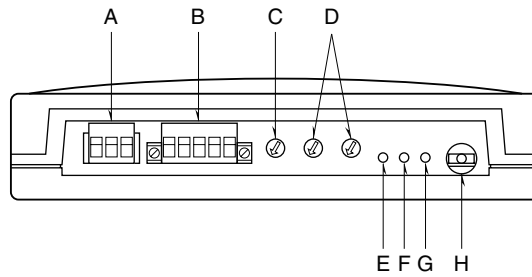

	NAME	FUNCTIONS	
<b>A</b>	Power terminal block	For power input	
<b>B</b>	Network terminal block	For wiring to DeviceNet	
<b>C</b>	Baud rate setting	125, 250, 500 kbps (factory set to: 125 kbps)	
<b>D</b>	Node address setting	Selectable within 00 – 63 (factory set to: 00)	
<b>E</b>	NS (Network Status) indicator LED	COLOR	FUNCTIONS
		Red	ON: Critical communication error blinking: Minor communication error
		Green	ON: Communication established blinking: Communication down
----	OFF: Power Not supplied		
<b>F</b>	MS (Module Status) indicator LED	COLOR	FUNCTIONS
		Red	ON: Critical failure blinking: Minor failure
		Green	ON: Normal conditions blinking: Device Not configured
----	OFF: Power Not supplied		
<b>G</b>	Power LED	COLOR	FUNCTIONS
		Green	ON: Power supplied
		----	OFF: Power Not supplied
<b>H</b>	Configurator jack	2.5 dia. miniature jack; RS-232-C level	

## CONNECTION DIAGRAM

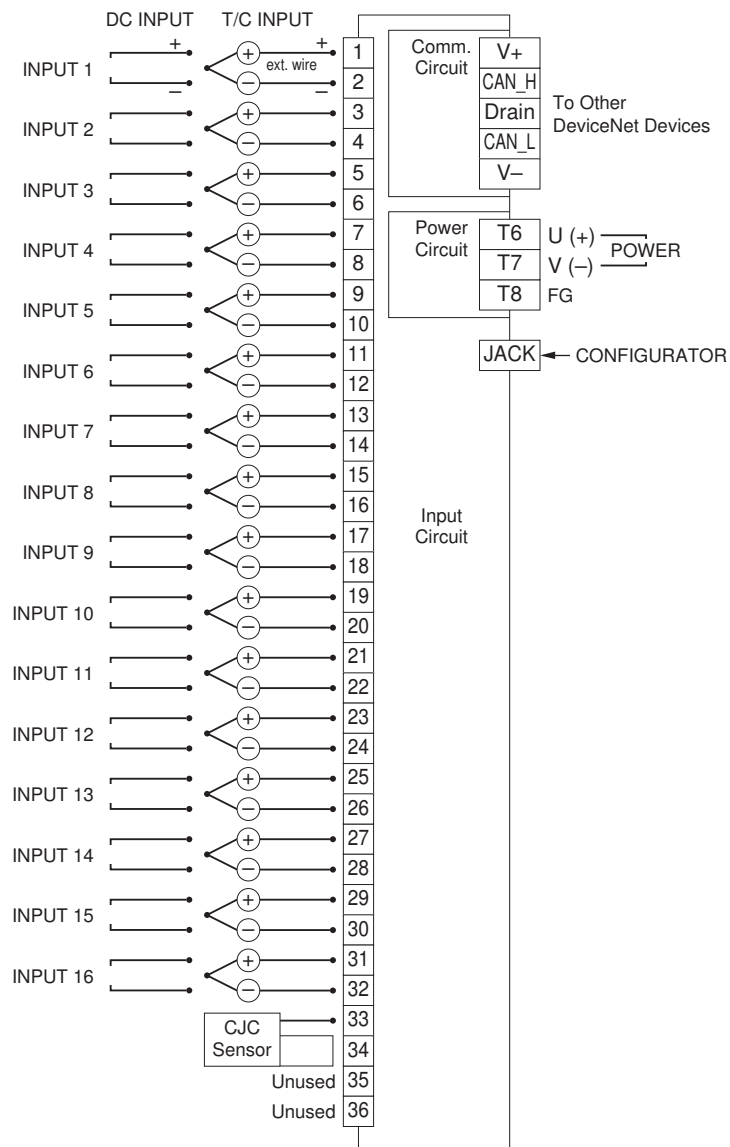

Note 1: This device is not designed to cancel noise included in the input signals.  
 Be careful to eliminate such noise by using shielded cables.  
 Note 2: Be sure to maintain the same potential at all the common negative terminals for DC input.  
 Caution: FG terminal is NOT a protective conductor terminal.

## EXTERNAL DIMENSIONS & TERMINAL ASSIGNMENTS unit: mm [inch]

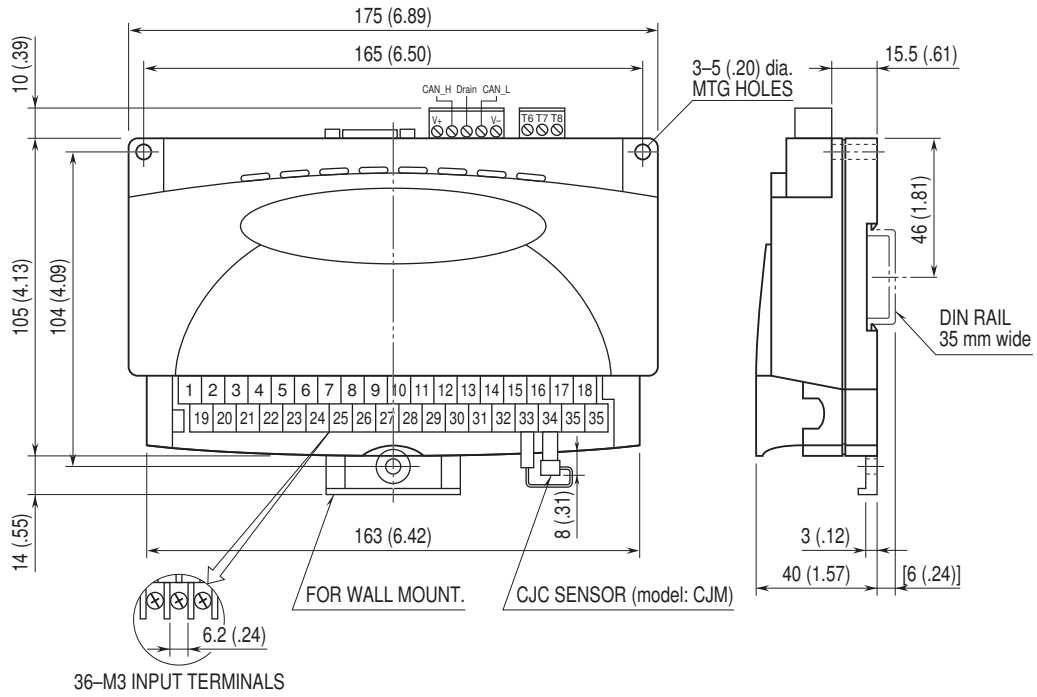

Specifications are subject to change without notice.