

Remote I/O R3 Series

MODBUS INTERFACE MODULE

Functions & Features

- Enables other protocol interface modules to communicate with Modbus data (gateway).
- Recognized as an analog I/O mixed module by other protocol interface modules.
- Used as Modbus slave device like R3-NM1.

Typical Applications

- A gateway for CC-Link and Modbus.

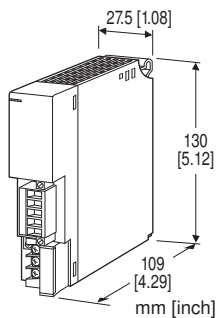

MODEL: R3-GM1S[1]

ORDERING INFORMATION

- Code number: R3-GM1S[1]
Specify a code from below for [1].
(e.g. R3-GM1S/CE/Q)
- Specify the specification for option code /Q
(e.g. /C01)

COMMUNICATION MODE

S: Single

[1] OPTIONS (multiple selections)

Standards & Approvals

blank: Without CE

/CE: CE marking

Other Options

blank: none

/Q: Option other than the above (specify the specification)

SPECIFICATIONS OF OPTION: Q

COATING (For the detail, refer to our web site.)

/C01: Silicone coating

/C02: Polyurethane coating

/C03: Rubber coating

CAUTION

- When selecting network modules, note that this unit is not designed to be used with network modules of certain types or versions.
- This unit CANNOT be used with R3-NC2, R3-NEIP1, R3-NFx, and R3-NLx.
- This unit CAN be used with:
R3-NM3 and R3-NML3 of firmware version V1.00 or higher;
R3-NC1, R3-NC3, R3-NDx, R3-NE1, R3-NFL1, R3-NM1, R3-NM4, and R3-NP1 of firmware version V2.00 or higher;
and
other models of any firmware versions.

PACKAGE INCLUDES...

- Terminating resistor (110 Ω, 0.25 W)

GENERAL SPECIFICATIONS

Connection

Modbus: Euro type connector terminal
(applicable wire size: 0.2 to 2.5 mm², stripped length 7 mm)

Internal bus: Via the Installation Base
(model: R3-BSx)

Internal Power: Via the Installation Base
(model: R3-BSx)

RUN contact output: M3 separable screw terminal
(torque 0.5 N·m)

Screw terminal: Nickel-plated steel

Isolation: Modbus to internal bus or internal power to RUN contact output

RUN indicator: Bi-color (green/red) LED
Green turns ON when Modbus communication is normal and fieldbus communication on the R3 Network module side is also normal; or

Red turns ON when receiving data.

Indication selectable with DIP SW3-4.

ERR indicator: Bi-color (green/red) LED
Green turns ON/blinks in communication errors (OFF with wire breakdown; Green blinks with setting errors); or
Red turns ON when transmitting data.

Indication selectable with DIP SW3-4.

Module allocation: Set with the side DIP switch.

■ RUN CONTACT OUTPUT

RUN contact: Turns on while the green RUN LED is ON (only when Modbus communication and the field bus built-in the interface module are in normal).

Rated load: 250 V AC @ 0.5 A (cos φ = 1)

30 V DC @ 0.5 A (resistive load)

(Less than 50 V AC to conform with EU Directive)

Maximum switching voltage: 250 V AC or 30 V DC

Maximum switching power: 250 VA or 150 W

Minimum load: 1 V DC @ 1 mA

Mechanical life: 2×10^7 cycles (300 cycles/min.)

When driving an inductive load, external contact protection and noise quenching recommended.

MODBUS COMMUNICATION

Standard: Conforms to TIA/EIA-485-A

Transmission distance: 500 meters max.

Transmission media: Shielded twisted-pair cable (CPEV-S 0.9 dia.)

Transmission setting: DIP switch (front)

Data mode: RTU (Binary) or ASCII

Parity: None, even or odd

Baud rate: 4800, 9600, 19.2 k, 38.4 k (bps)

Node address: Rotary switch; 01 - F7

INSTALLATION

Operating temperature: -10 to +55°C (14 to 131°F)

Operating humidity: 30 to 90 %RH (non-condensing)

Atmosphere: No corrosive gas or heavy dust

Mounting: Installation Base (model: R3-BSx)

Weight: 200 g (0.44 lb)

PERFORMANCE

Data allocation: $16 \times n$ (Module allocation: 1 to 8)

Current consumption: 100 mA

Insulation resistance: $\geq 100 \text{ M}\Omega$ with 500 V DC

Dielectric strength: 1500 V AC @ 1 minute

(Modbus to internal bus or internal power to RUN contact output)

2000 V AC @ 1 minute (power input to FG; isolated on the power supply module)

STANDARDS & APPROVALS

EU conformity:

EMC Directive

EMI EN 61000-6-4

EMS EN 61000-6-2

RoHS Directive

EXTERNAL VIEW

FRONT VIEW

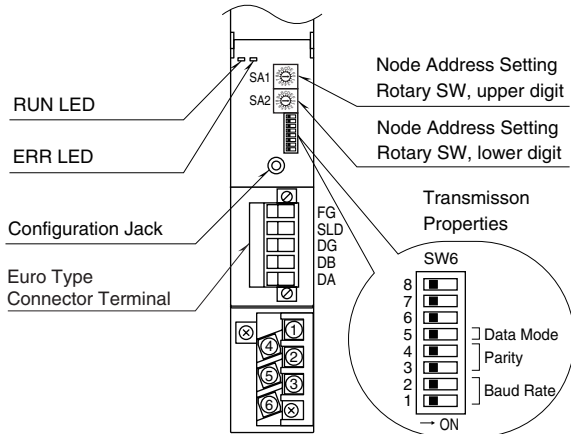

SIDE VIEW

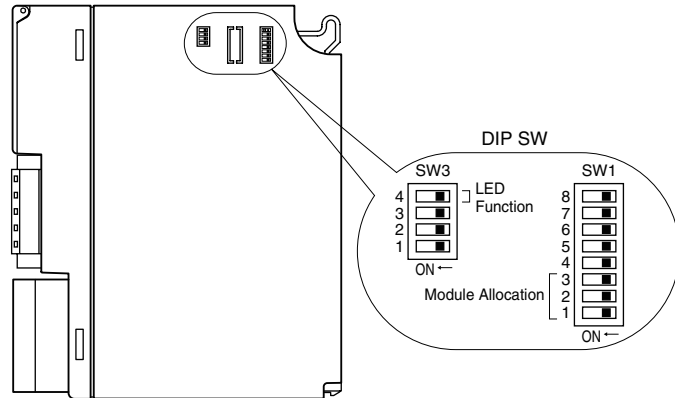

COMMUNICATION CABLE CONNECTIONS

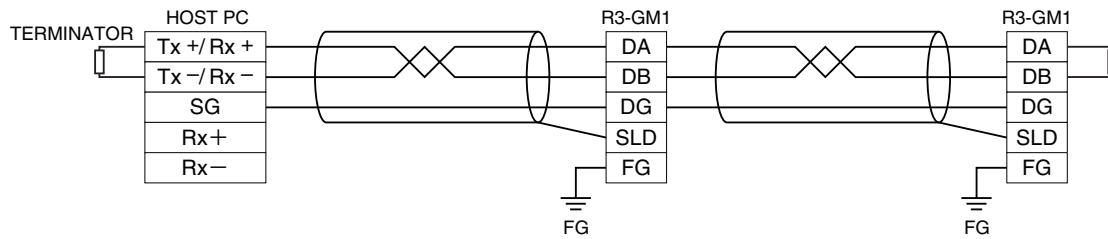

MODBUS FUNCTION CODES & SUPPORTED CODES

■ Data & Control Functions

CODE	NAME		
01	Read Coil Status		Digital output from the slave
02	Read Input Status	X	Status of digital inputs to the slave
03	Read Holding Registers	X	General purpose register within the slave
04	Read Input Registers	X	Collected data from the field by the slave
05	Force Single Coil		Digital output from the slave
06	Preset Single Register	X	General purpose register within the slave
07	Read Exception Status		
08	Diagnostics	X	
09	Program 484		
10	Poll 484		
11	Fetch Comm. Event Counter		Fetch a status word and an event counter
12	Fetch Comm. Event Log		A status word, an event counter, a message count and a field of event bytes
13	Program Controller		
14	Poll Controller		
15	Force Multiple Coils	X	Digital output from the slave
16	Preset Multiple Registers	X	General purpose register within the slave
17	Report Slave ID		Slave type / 'RUN' status
18	Program 884/M84		
19	Reset Comm. Link		
20	Read General Reference		
21	Write General Reference		
22	Mask Write 4X Register		
23	Read/Write 4X Register		
24	Read FIFO Queue		

■ Exception Codes

CODE	NAME		
01	Illegal Function	X	Function code is not allowable for the slave
02	Illegal Data Address	X	Address is not available within the slave
03	Illegal Data Value	X	Data is not valid for the function
04	Slave Device Failure		
05	Acknowledge		
06	Slave Device Busy		
07	Negative Acknowledge		
08	Memory Parity Error		

■ Diagnostic Subfunctions

CODE	NAME		
00	Return Query Data	X	Loop back test
01	Restart Comm. Option	X	Reset the slave and clear all counters
02	Return Diagnostic Register	X	Contents of the diagnostic data (2 bytes)
03	Change ASCII Input Delimiter	X	Delimiter character of ASCII message
04	Force Listen Only Mode	X	Force the slave into Listen Only Mode

MODBUS I/O ASSIGNMENT

	ADDRESS	DATA TYPE	DATA	MODULE POSITION
Input (1X)	1025 – 1032		Module Status	
Input Registers (3X)	1 – 16	I	Analog Input	1
	17 – 32			2
	33 – 48			3
	49 – 64			4
	65 – 80			5
	81 – 96			6
	97 – 112			7
	113 – 128			8
	257 – 288	F	Analog Input	1
	289 – 320			2
	321 – 352			3
	353 – 384			4
	385 – 416			5
	417 – 448			6
	449 – 480			7
	481 – 512			8
Holding Registers (4X)	1 – 16	I	Analog Output	1
	17 – 32			2
	33 – 48			3
	49 – 64			4
	65 – 80			5
	81 – 96			6
	97 – 112			7
	113 – 128			8
	257 – 288	F	Analog Output	1
	289 – 320			2
	321 – 352			3
	353 – 384			4
	385 – 416			5
	417 – 448			6
	449 – 480			7
	481 – 512			8

■ DATA TYPE

I: Integer, 0 – 10000 (0 – 100%)

F: Floating (32-bit data cannot be accessed via floating addresses.)

Note: DO NOT access addresses other than the ones mentioned above. Such access may cause problems such as malfunction.

• Module Status

Module Status indicates whether individual I/O module is mounted or not. The bit corresponding to the mounted slot turns to “1,” and the unmounted slot to “0.”

TRANSMISSION DATA DESCRIPTIONS

Use the DIP SW located at the side of the module to specify module allocation.

1 module is equivalent to 1 I/O module with 16 words analog input and 16 words analog output. Max. 8 modules (128 words input, 128 words output) transmission is available. R3-GM1 seems as if max. 8 I/O modules are mounted to 8 slots via Modbus. The input of the module is processed as follows.

Modbus Communication --> R3-GM1 Module --> R3 Base --> R3 Communication Module

In responding to the input, the output (Holding Register) command becomes valid via Modbus communication, and the input (Input Register) command is valid in the output.

Note: Do not mount any modules in the slots which are occupied by virtual modules. If a real I/O module is mounted in the slot, an internal bus error occurs. Max. 16 real I/O modules and virtual modules are available. The interface module can not read the data for more than 16 modules.

■ WHEN R3-GM1 IS MOUNTED ON SLOT NO. 2 (4 modules)

Real I/O modules are mounted on Slots No. 1 and 2, however, the network module (R3-NC3) recognizes that each of Slots No. 1 to 5 is occupied. That is, R3-NC3 recognizes R3-SV4 mounted on Slot No.1 as it is and recognizes R3-GM1 mounted on Slot No.2 as divided into four modules and occupying Slots No. 2 to 5.

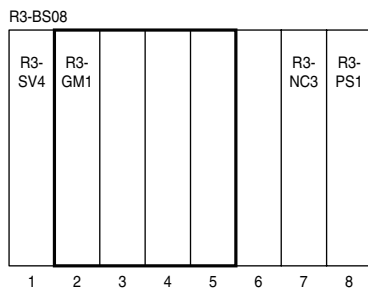

SLOT	REAL MODULE	VERTUAL MODULE	NO. OF WORDS
Slot No.1	R3-SV4	R3-SV4	4 Words
Slot No.2	R3-GM1	R3-GM1 (1/4)	16 Words
Slot No.3	No module	R3-GM1 (2/4)	16 Words
Slot No.4	No module	R3-GM1 (3/4)	16 Words
Slot No.5	No module	R3-GM1 (4/4)	16 Words
Slot No.6	No module	No module	----
Slot No.7	R3-NC3	R3-NC3	----
Slot No.8	R3-PS1	R3-PS1	----

I/O DATA DESCRIPTIONS

■ MODULE STATUS, DATA ERROR STATUS

Shows each module's availability and error status.

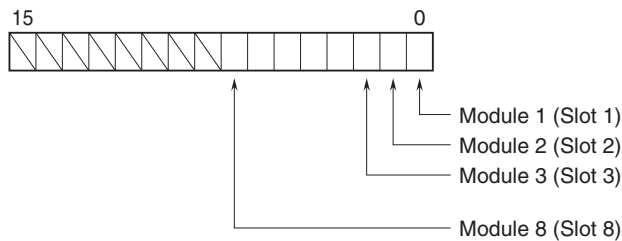

■ ANALOG DATA

16-bit binary data.



EXTERNAL DIMENSIONS & TERMINAL ASSIGNMENTS unit: mm [inch]

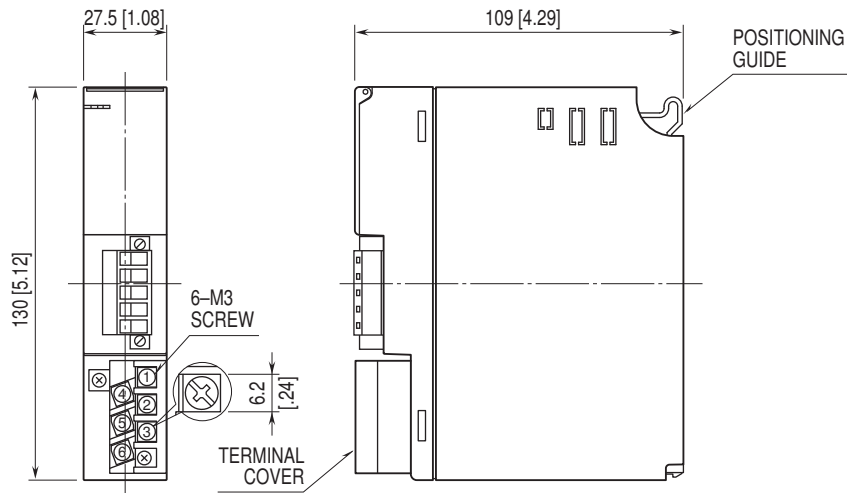

SCHEMATIC CIRCUITRY & CONNECTION DIAGRAM

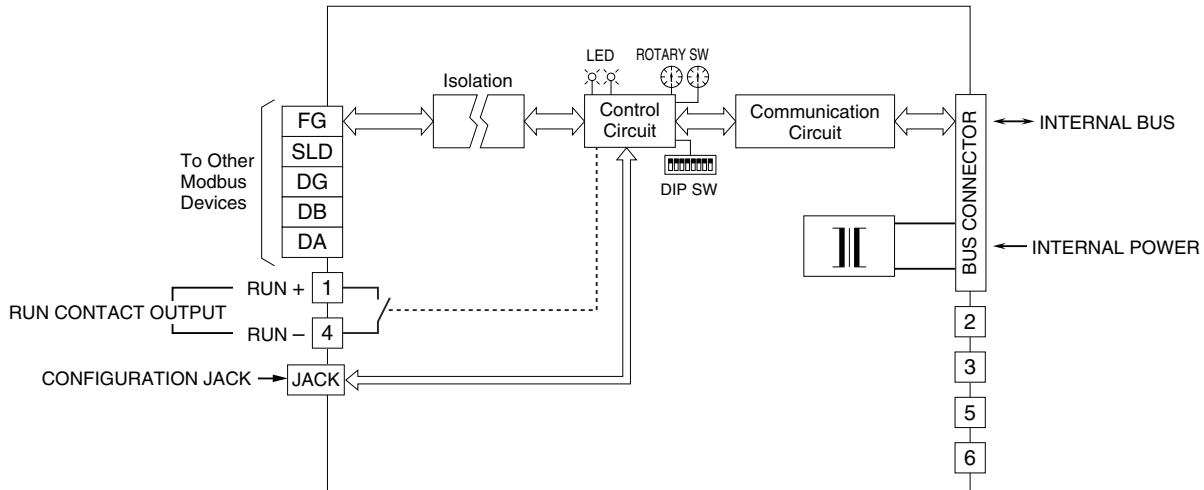

SYSTEM CONFIGURATION EXAMPLES

In the following system configuration, Modbus data is converted to CC-Link data via this unit which is used as a gateway.

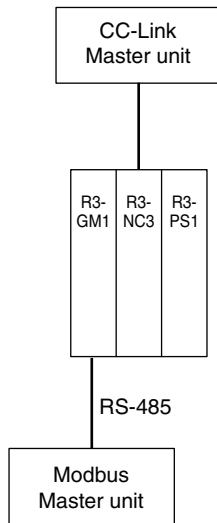

Specifications are subject to change without notice.