

Remote I/O R3 Series

/C02: Polyurethane coating

/C03: Rubber coating

VALVE POSITIONER MODULE

(for 2 systems; built-in SSR)

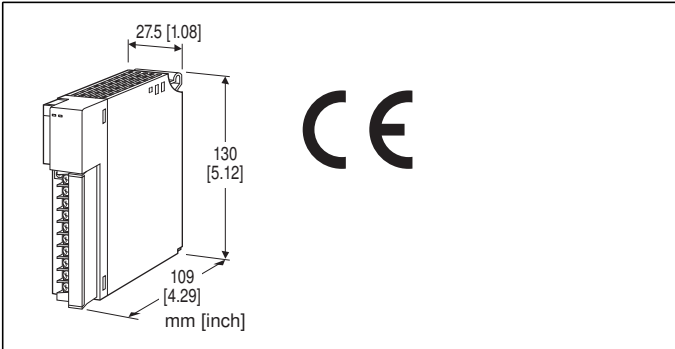

MODEL: R3-MEX2[1][2]

ORDERING INFORMATION

- Code number: R3-MEX2[1][2]
- Specify a code from below for each of [1] and [2].
(e.g. R3-MEX2W/CE/Q)
- Specify the specification for option code /Q
(e.g. /C01)

VALVE POSITIONER

2: 2 systems

FEEDBACK RESISTANCE

Potentiometer input

CONTROL OUTPUT

Built-in SSR

[1] COMMUNICATION MODE

S: Single

W: Dual

[2] OPTIONS (multiple selections)

Standards & Approvals

blank: Without CE

/CE: CE marking

Other Options

blank: none

/Q: Option other than the above (specify the specification)

SPECIFICATIONS OF OPTION: Q

COATING (For the detail, refer to our web site.)

/C01: Silicone coating

CAUTION

This unit is not designed to be used with the following types of interface modules (models: R3-NC2, R3-NEIP1, R3-NFx, R3-NLx).

Please use this unit with interface modules (models: R3-NC1, R3-NC3, R3-NDx, R3-NE1, R3-NFL1, R3-NM1, R3-NM4, R3-NP1) of firmware version V2.00 or higher, and interface modules (models: R3-NM3, R3-NML3) of firmware version V1.00 or higher.

GENERAL SPECIFICATIONS

Connection

Internal bus: Via the Installation Base (model: R3-BSx)

Input, Output: M3 separable screw terminal
(torque 0.5 N·m)

Internal power: Via the Installation Base (model: R3-BSx)

Screw terminal: Nickel-plated steel

Full-close position setting range:

0 - 25 % (factory default: 0 %)

Full-open position setting range:

75 - 100 % (factory default: 100 %)

Deadband adjustment:

0.1 - 8.0 % adjustable (factory default: 1.5 %)

Restart limiting timer:

0.5 to 10 sec. (factory default: 2 sec.)

Motor deadlock detecting time:

60 - 1000 sec. (factory default: 120 sec.)

Isolation: Control output 1 to control output 2 to feedback potentiometer 1 or feedback potentiometer 2 or internal bus or internal power

RUN indicator: Bi-color (red/green) LED;

Red when the bus A operates normally;

Green when the bus B operates normally;

Amber when both buses operate normally.

ERR indicator: Green LED turns on in normal operating conditions.

INPUT SPECIFICATIONS

■ **Feedback Potentiometer:** 100 Ω - 10 kΩ

Minimum span: 50 % of total resistance

Excitation: Approx. 3.3 V DC

OUTPUT SPECIFICATIONS

■ **Control Output:** SSR (zero-crossing); 20 - 240 V AC 0.1 - 1 A

Leakage current at OFF: Approx. 10 mA @ 240 V AC

Output operation at loss of communication: When a communication error occurs in the middle of an output operation, the operation continues toward until reaching target position most recently set by Host device.

Output Operation: (terminal No. in parentheses)

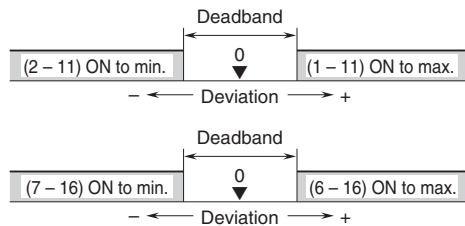

INSTALLATION

Operating temperature: -10 to +55°C (14 to 131°F)

Operating humidity: 30 to 90 %RH (non-condensing)

Atmosphere: No corrosive gas or heavy dust

Mounting: Installation Base (model: R3-BSx)

Weight: 190 g (0.42 lb)

PERFORMANCE

■ **POSITION FEEDBACK INPUT**

Conversion accuracy: $\pm 0.4\%$

The conversion accuracy is defined against the potentiometer's full span.

Conversion rate: 10 msec.

Data range: 0 - 1000

Data allocation: 4

Current consumption: Approx. 50 mA

Temp. coefficient: $\pm 0.015\%/^{\circ}\text{C}$ ($\pm 0.008\%/^{\circ}\text{F}$)

Temperature coefficient is defined against the potentiometer's full span.

Insulation resistance: $\geq 100\text{ M}\Omega$ with 500 V DC

Dielectric strength:

2000 V AC @1 minute (control output 1 to control output 2 to position feedback 1 or position feedback 2 or internal bus or internal power)

2000 V AC @1 minute (power input to FG; isolated on the power supply module)

STANDARDS & APPROVALS

EU conformity:

EMC Directive

EMI EN 61000-6-4

EMS EN 61000-6-2

Low Voltage Directive

EN 61010-1, EN 61010-2-201

Measurement Category II (control output)

Pollution degree 2

Position feedback 1 or position feedback 2 to control

output 1 to control output 2: Reinforced insulation (300 V)

RoHS Directive

FUNCTIONS

• **SSR (Solid State Relay)**

SSR consists only of semiconductor elements, and thus SSR is free from arc discharge and chattering which are typical with electromagnetic relays.

SSR has excellent durability against vibration, physical impact, and environmental influences.

• **Zero-Cross Function**

SSR with zero-cross function turns on when AC power voltage is near zero.

When input is provided in the middle of a wave cycle, SSR delays switching until the next time the voltage becomes near zero, thus limiting transient switching noise voltage and rush current.

EXTERNAL VIEW

■ FRONT VIEW

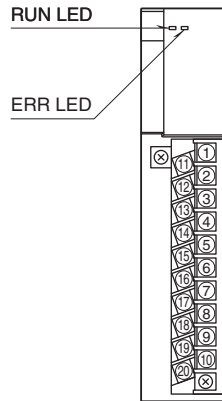

EXTERNAL DIMENSIONS & TERMINAL ASSIGNMENTS unit: mm [inch]

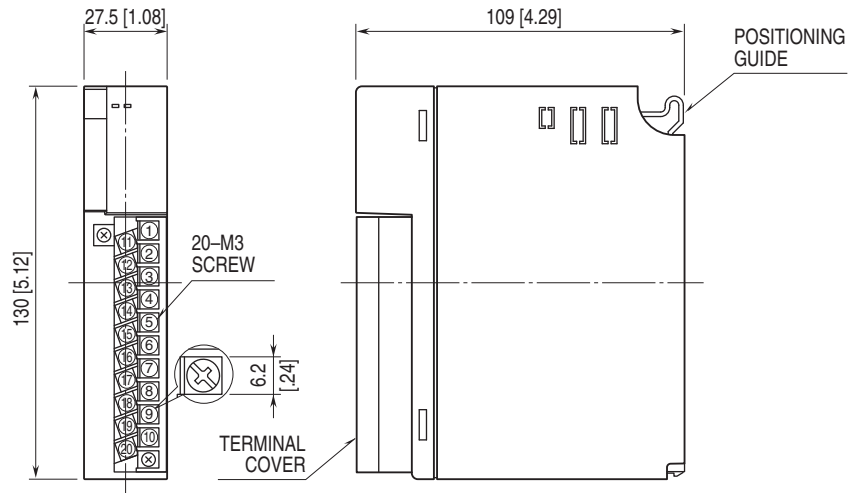

SCHEMATIC CIRCUITRY & CONNECTION DIAGRAM

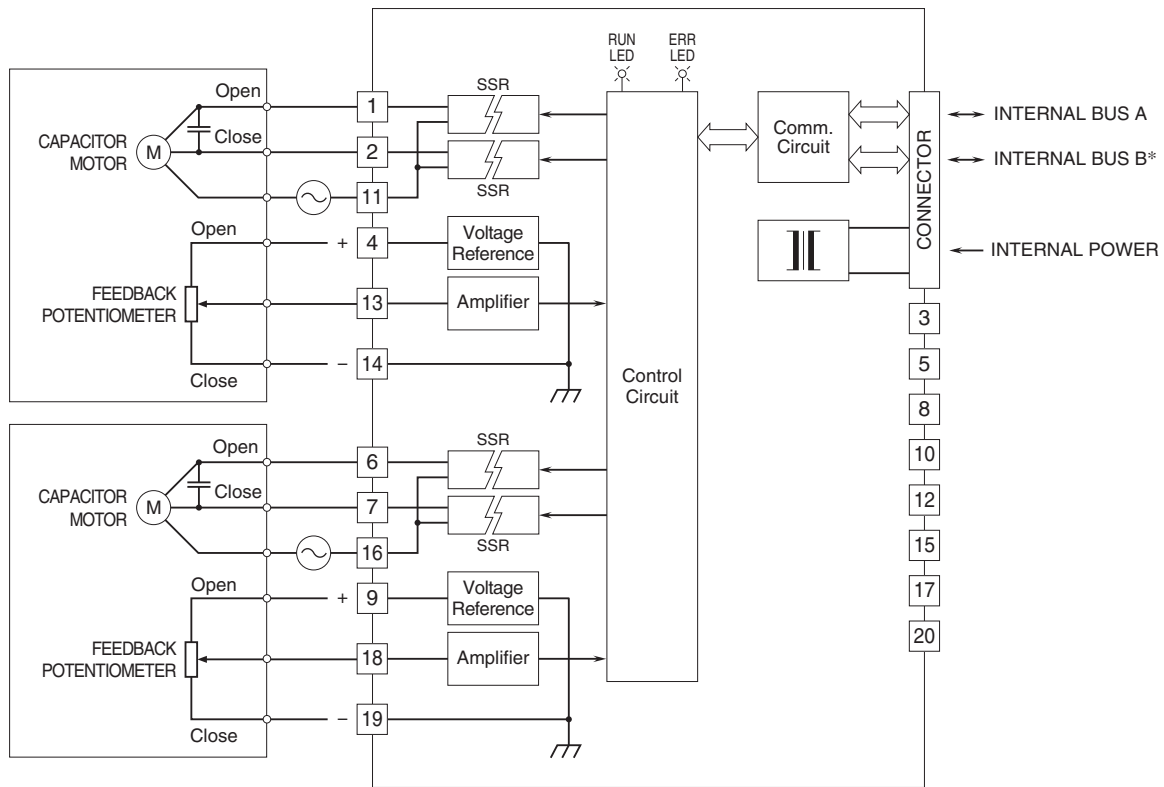

* For dual redundant communication type module only.



Specifications are subject to change without notice.