

Remote I/O R3 Series

TOTALIZED PULSE INPUT MODULE

(Pi 8 points, 32 Bits, tension clamp terminal block)

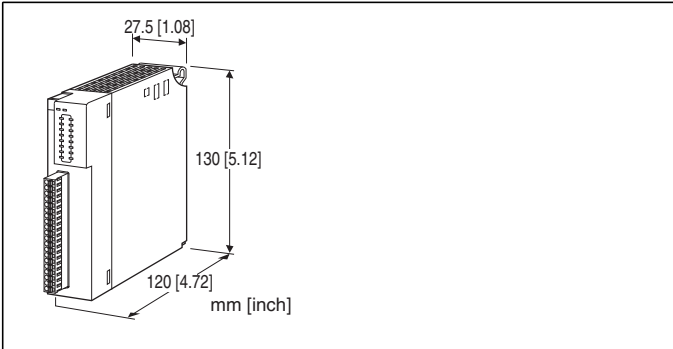

MODEL: R3S-PA8[1][2]

ORDERING INFORMATION

- Code number: R3S-PA8[1][2]
- Specify a code from below for each of [1] and [2].
(e.g. R3S-PA8W/PRS/Q)
- Specify the specification for option code /Q
(e.g. /C01/SET)

NO. OF CHANNELS

8: 8

[1] COMMUNICATION MODE

S: Single

W: Dual

[2] OPTIONS (multiple selections)

EX-FACTORY SETTING

blank: Enable count reset by host PC/PLC

/PRS: Enable count preset by host PC/PLC

Other Options

blank: none

/Q: Option other than the above (specify the specification)

SPECIFICATIONS OF OPTION: Q (multiple selections)

COATING (For the detail, refer to our web site.)

/C01: Silicone coating

/C02: Polyurethane coating

/C03: Rubber coating

EX-FACTORY SETTING

/SET: Preset according to the Ordering Information Sheet

(No. ESU-8457)

RELATED PRODUCTS

- Interface module (model: R3-NCx, R3-NCIE1, R3-NE1, R3-NMx, R3-NDx, R3-NFL1, R3-NP1, R3-NFx, R3-NML3, R3-NF2: Firmware version V0.05 or later)

Note:

- Count reset by host PC/PLC:

Available with this unit and the above mentioned interface modules of firmware version V2.00 or later, except R3-NFx (R3-NM3: Firmware version V1.00 or later). Notice that Count reset by host PC/PLC via R3-NFx or interface module of previous versions of firmware is unable.

- Count preset by host PC/PLC:

It is only available in combination with this unit displayed 'SW3-4 RESET/PRESET' on the right side panel and the interface module R3-NMx or R3-NE1 of firmware version V2.00 or later. Count preset is not available for other combination (R3-NM3: Firmware version V1.00 or later). Notice that this function is not available in the same time as count preset by host PC/PLC.

- In the FL-net Configuration Builder software (model: R3-NFLBLD), the number of channel for this module is displayed as 16 because data has 8 channels x 2 words.

GENERAL SPECIFICATIONS

Connection

Internal bus: Via the Installation Base (model: R3-BSx)

Input: Separable tension clamp terminal (applicable wire size: 0.2 to 1.5 mm², stripped length 10 mm)

Internal power: Via the Installation Base (model: R3-BSx)

Isolation: Input to internal bus or internal power

RUN indicator: Bi-color (red/green) LED;

Red when the bus A operates normally;

Green when the bus B operates normally;

Amber when both buses operate normally.

ERR indicator: Bi-color (red/green) LED;

Red with excitation abnormality;

Green in normal operating conditions.

Input status indicator: Red LED;

1 to 8: Turns on with the input ON.

9 to 15: Unused

16: Turns on with the reset input ON.

Count reset: Via DIP switch on the side or one pulse to reset input

Count setting from host PC/PLC: Count reset/count preset is changeable via DIP switch on the side.

INPUT SPECIFICATIONS

Number of input: 9 (8 points + Count reset)

Input resistance: 6 kΩ

Common: Negative commons, all points; 11 terminals

Maximum frequency: 100 Hz

(ON/OFF time \geq 5 msec.)

This unit is designed to be able to accept a frequency up to 100 Hz, however, 'chattering' contact must be avoided for accurate measuring of such high frequency. Use relays that do not cause any chattering.

Totalized pulse range: 0 - 9999999

Count at overflow: Reset and restart at '0.' (Max. pulse range selectable from 10000 to 2147483647 using the R3CON PC Configurator Software. '0' or '1' from which restart counting at overflow is pre-settable. Refer to the R3CON Users Manual for detailed information.)

■ INTERNAL EXCITATION

Sensing voltage: 13 V DC (max. 24 V with no load)

ON voltage: \geq 9 V (\leq 1.5 k Ω)

OFF voltage: \leq 4.5 V (\geq 18 k Ω)

INSTALLATION

Operating temperature: -10 to +55°C (14 to 131°F)

Operating humidity: 30 to 90 %RH (non-condensing)

Atmosphere: No corrosive gas or heavy dust

Mounting: Installation Base (model: R3-BSx)

Weight: 200 g (0.44 lb)

PERFORMANCE

Data allocation: 16

Current consumption: 70 mA

Insulation resistance: \geq 100 M Ω with 500 V DC

Dielectric strength: 2000 V AC @ 1 minute

(input to internal bus or internal power)

2000 V AC @ 1 minute (power input to FG; isolated on the power supply module)

COUNT RESET

There are three different ways to reset count value.

■ COUNT RESET WITH DIP SW

- 1) Remove Network Module or its cables and interrupt communication with other devices.
- 2) Turn ON the Count Reset SW (DIP SW3-1) on R3S-PA8 module.
- 3) Return the module to the base and turn the power supply on.
- 4) ERR LED turns on and the module starts resetting its counter. When the resetting is complete, the LED turns to green. DO NOT remove the power while the red LED is on.
- 5) After confirming that ERR LED is green, turn the power supply off.
- 6) Turn OFF the Count Reset SW (DIP SW3-1).
- 7) Return the Network module onto the base and turn the power supply on.

Note: Count Reset SW must be turned OFF after this procedure because the module does not start counting with

ON state. Even when the count overflow set value is 1, the counter is reset to 0.

■ COUNT RESET WITH RESET SIGNAL

With the Count Reset Input SW (DIP SW3-3) turned ON, the count reset signal value becomes effective.

SW3-3 = OFF: invalid

SW3-3 = ON: valid

One pulse supplied at the Count reset input terminal will be recognized as a reset signal.

1) ERR LED turns on (red color) when the reset signal is received.

2) In 1 second, the module starts resetting its counter. When the resetting is complete, the LED turns to green.

3) After 1 second, ERR LED turns back to the state before the reset signal has been received.

Note: Reset signals received while the module is processing (1) through (3) are ignored. Even when the count overflow set value is 1, the counter is reset to 0.

■ COUNT RESET FROM HOST PC/PLC

Refer to "COUNTER SETTING FROM HOST PC/PLC" section hereafter.

EXTERNAL VIEW

FRONT VIEW

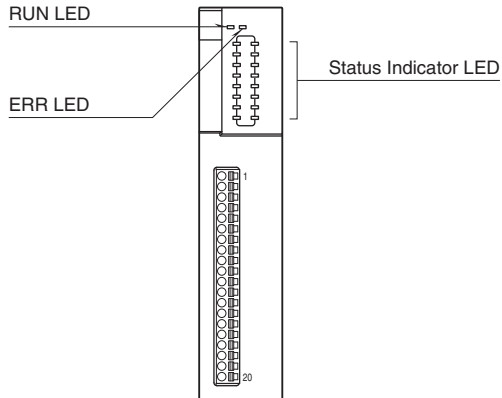

SIDE VIEW

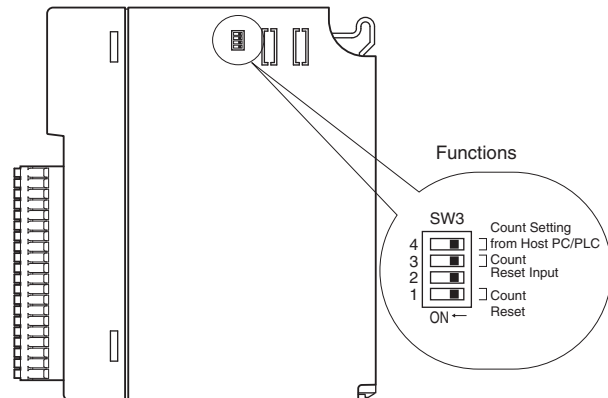

Set the Count Reset SW to OFF to start counting.

COUNTER SETTING FROM HOST PC/PLC

COUNTER RESET

(Available for R3-NCx, R3-NCIE1, R3-NE1, R3-NMx, R3-NDx, R3-NFL1, R3-NP1, R3-NML3 (Firmware version 2.00 or later, R3-NM3: Firmware version V1.00 or later))

Setting SW3-4 OFF and turning power on enable the function.

The bits indicating the channels to reset counter are allocated in the first word from host PC/PLC.

When these bits are changed from 0 to 1, the counter is reset. When it is confirmed that the counter is reset, return to 0.

Notice that if the bit remains at 1, the next reset will not work.

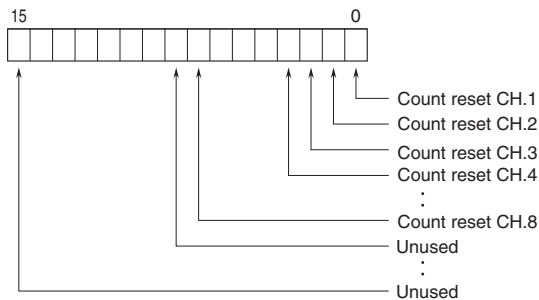

COUNTER PRESET

(Available in combination with R3-NE1, R3-NMx (Firmware version 2.00 or later, R3-NM3: Firmware version V1.00 or later), and R3S-PA8 displayed 'SW3-4 RESET/PRESET' on the right side)

Setting SW3-4 ON and turning power on enable the function.

Write the preset value to the Holding Registers, which has same address as the Input Registers.

When writing the same preset value consecutively, perform the following steps.

- Reset the power of the main unit.
- Temporarily write a different preset value. (e.g. 1000 > 2000 > 1000 etc.)

Input Registers

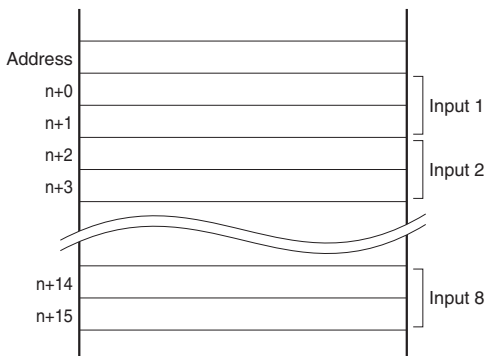

Holding Registers

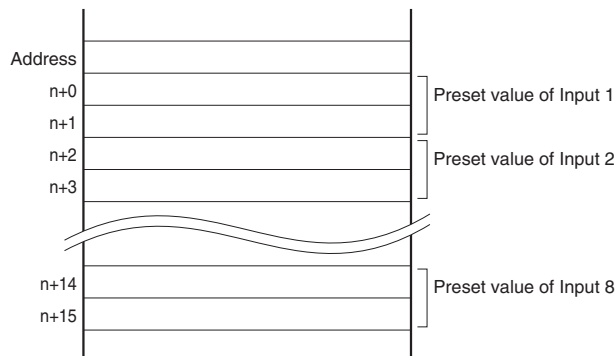

EXTERNAL DIMENSIONS unit: mm [inch]

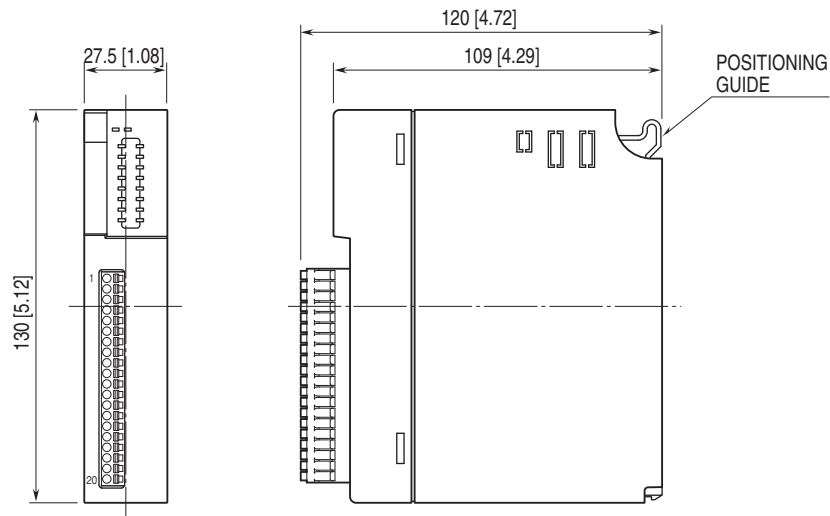

SCHEMATIC CIRCUITRY & CONNECTION DIAGRAM

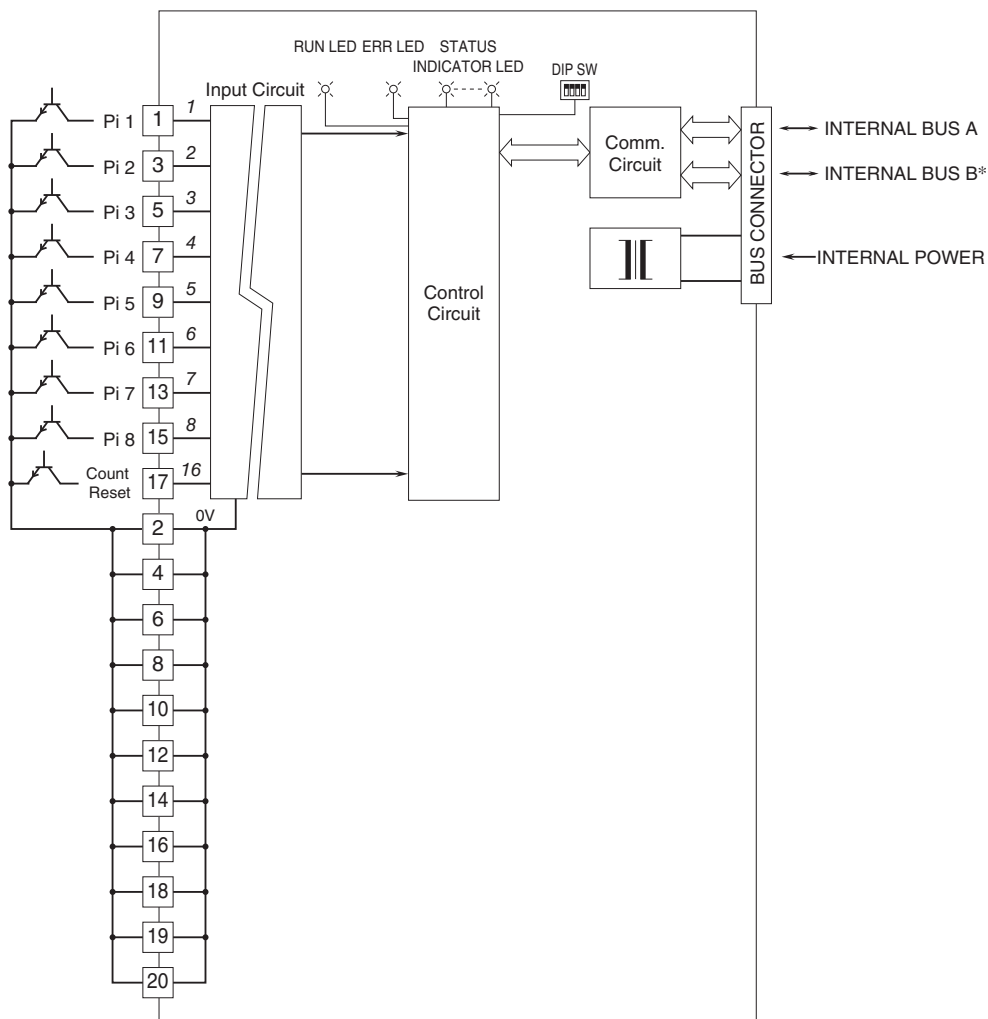

Numbers in italic indicate LED No.s assigned to the front panel LEDs.
 *For dual redundant communication.

INPUT TERMINAL ASSIGNMENT

PIN No.	FUNCTION
1	Pi 1
2	COM
3	Pi 2
4	COM
5	Pi 3
6	COM
7	Pi 4
8	COM
9	Pi 5
10	COM
11	Pi 6
12	COM
13	Pi 7
14	COM
15	Pi 8
16	COM
17	RESET
18	COM
19	COM
20	COM



Specifications are subject to change without notice.