

## Remote I/O R3 Series

### AC POWER INPUT MODULE

(4 input circuits)

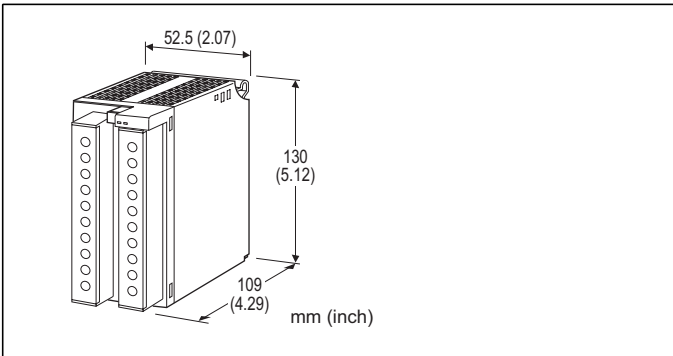

### MODEL: R3-WT4[1][2]1[3][4]

#### ORDERING INFORMATION

- Code number: R3-WT4[1][2]1[3][4]
- Specify a code from below for each of [1] through [4]. (e.g. R3-WT4111S/Q)
- Specify the specification for option code /Q (e.g. /C01)

#### NO. OF CHANNELS

4: 4

#### [1] CONFIGURATION

- 1: 3-phase / 3-wire
- 2: Single-phase / 2-wire
- 3: Single-phase / 3-wire

#### [2] INPUT (unbalanced load)

- 1: 110 V / 5 A AC
- 2: 110 V / 1 A AC
- 3: 220 V / 1 A AC
- 4: 220 V / 5 A AC
- A: 100 V / 200 V / 1 A AC (single-phase / 3- wire)
- B: 100 V / 200 V / 5 A AC (single-phase / 3- wire)

#### MEASURING VARIABLE

- 1: Active power / active energy

#### [3] COMMUNICATION MODE

- S: Single
- W: Dual

#### [4] OPTIONS

- blank: none
- /Q: With options (specify the specification)

#### SPECIFICATIONS OF OPTION: Q

- COATING (For the detail, refer to our web site.)
- /C01: Silicone coating
- /C02: Polyurethane coating
- /C03: Rubber coating

#### RELATED PRODUCTS

- PC configurator software (model: R3CON)
- The R3CON is used to set up the software setting of this module. Downloadable at our web site.

#### GENERAL SPECIFICATIONS

##### Connection

- Internal bus:** Via the Installation Base (model: R3-BSx)
- Input:** M3.5 screw terminals (torque 0.8 N·m)
- Internal power:** Via the Installation Base (model: R3-BSx)
- Screw terminal:** Nickel-plated steel
- Isolation:** Voltage input to current input 1 to current input 2 to current input 3 to current input 4 to internal bus or internal power

##### Computation: Time division multiplication

##### DIP switch settings:

- Measuring variables
- Computation methods
- Count Reset (Disable/Enable)
- Others

Refer to the instruction manual for details.

- RUN indicator:** Bi-color (red/green) LED; Red when the bus A operates normally; Green when the bus B operates normally; Amber when both buses operate normally.

##### ERR indicator: Bi-color (red/green) LED;

- Red with input abnormality;
- Green in normal operating conditions.

##### Power ON timer: Starts conversion in 10 seconds after the power is turned on.

##### Low-end cutout: Converted data forced to 0 % for 2 % or less input. (Selectable by using R3CON)

#### INPUT SPECIFICATIONS

Frequency: 50 or 60 Hz

##### • Voltage Input

Operational range: 0 - 120 % of rating

Overload capacity: 150 % of rating for 10 sec., 120 % continuous

##### • Current Input

**Operational range:** 0 - 120 % of rating

**Overload capacity:** 1000 % of rating for 3 sec., 200 % for 10 sec., 120% continuous

■ **Active Power Input Range**

Choose VT and CT ratios so that the calibration range calculated by the following equation is within the usable range in the table at the end of this section.

$$\text{Calibration Range [W]} = \text{Measuring Wattage [W]} \div [(\text{VT Ratio}) \times (\text{CT Ratio})]$$

•**Single-phase/2-wire**

INPUT	USABLE RANGE	BURDEN (VA)	
		VT	CT
110V / 1A	±100W	0.2	0.1
110V / 5A	±500W		0.5
220V / 1A	±200W	0.4	0.1
220V / 5A	±1000W		0.5

•**Single-phase/3-wire**

INPUT	USABLE RANGE	BURDEN (VA)	
		VT	CT
200V / 1A	±200W	0.2/phase	0.1/phase
200V / 5A	±1000W		0.5/phase

•**3-phase/3-wire**

INPUT	USABLE RANGE	BURDEN (VA)	
		VT	CT
110V / 1A	±200W	0.2/phase	0.1/phase
110V / 5A	±1000W		0.5/phase
220V / 1A	±400W	0.4/phase	0.1/phase
220V / 5A	±2000W		0.5/phase

## INSTALLATION

**Operating temperature:** -10 to +55°C (14 to 131°F)

**Operating humidity:** 30 to 90 %RH (non-condensing)

**Atmosphere:** No corrosive gas or heavy dust

**Mounting:** Installation Base (model: R3-BSx)

**Weight:** 600 g (1.3 lb)

## PERFORMANCE

**Accuracy**

(at 23°C ±10°C or 73.4°F ±18°F, 45 - 65 Hz)

**Active power:** ±1.0 %

**Active energy:** ±2 %

**Magnetic field (ext. origin) effect:** ± 0.5 % (400 A/m)

**Conversion rate:** 100 msec.

**Conversion data:** 16 bits / 32 bits

**Data allocation:** 4, 8 or 16 selectable

**Current consumption:** 150 mA

**Response time:** ≤ 2 sec. (0 - 100 % ±1 %)

**Insulation resistance:** ≥ 100 MΩ with 500 V DC

**Dielectric strength:** 2000 V AC @ 1 minute

(voltage input to current input 1 to current input 2 to current input 3 to current input 4 to internal bus or internal

power)

2000 V AC @ 1 minute (power input to FG; isolated on the power supply module)

**EXTERNAL VIEW**

■ FRONT VIEW

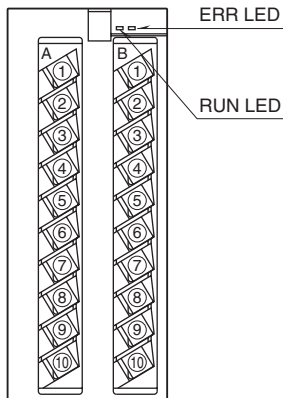

■ SIDE VIEW

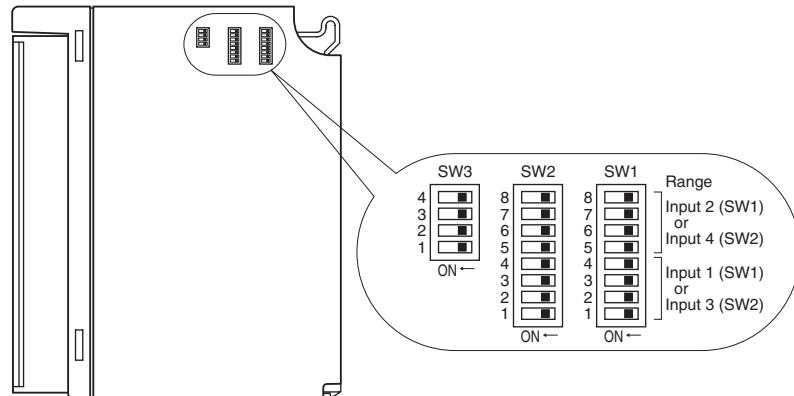

**TRANSMISSION DATA DESCRIPTIONS**

ADDRESS	VARIABLE A	active power 16 bits	active power 16 bits	incoming energy 16 bits	incoming energy 32 bits
	VARIABLE B	incoming energy 16 bits	incoming energy 32 bits	outgoing energy 16 bits	outgoing energy 32 bits
	VARIABLE C	outgoing energy 16 bits	----	----	----
n		active power ch.1	active power ch.1	incoming energy ch.1	incoming energy ch.1, lower digits
n + 1		active power ch.2	active power ch.2	incoming energy ch.2	incoming energy ch.1, upper digits
n + 2		active power ch.3	active power ch.3	incoming energy ch.3	incoming energy ch.2, lower digits
n + 3		active power ch.4	active power ch.4	incoming energy ch.4	incoming energy ch.2, upper digits
n + 4		incoming energy ch.1	incoming energy ch.1, lower digits	outgoing energy ch.1	incoming energy ch.3, lower digits
n + 5		incoming energy ch.2	incoming energy ch.1, upper digits	outgoing energy ch.2	incoming energy ch.3, upper digits
n + 6		incoming energy ch.3	incoming energy ch.2, lower digits	outgoing energy ch.3	incoming energy ch.4, lower digits
n + 7		incoming energy ch.4	incoming energy ch.2, upper digits	outgoing energy ch.4	incoming energy ch.4, upper digits
n + 8		outgoing energy ch.1	incoming energy ch.3, lower digits	0	outgoing energy ch.1, lower digits
n + 9		outgoing energy ch.2	incoming energy ch.3, upper digits	0	outgoing energy ch.1, upper digits
n + 10		outgoing energy ch.3	incoming energy ch.4, lower digits	0	outgoing energy ch.2, lower digits
n + 11		outgoing energy ch.4	incoming energy ch.4, upper digits	0	outgoing energy ch.2, upper digits
n + 12		0	0	0	outgoing energy ch.3, lower digits
n + 13		0	0	0	outgoing energy ch.3, upper digits
n + 14		0	0	0	outgoing energy ch.4, lower digits
n + 15		0	0	0	outgoing energy ch.4, upper digits
SW3-3 / SW3-4 setting		OFF / OFF	ON / OFF	OFF / ON	ON / ON
R3CON type ID		WT4***0	WT4***1	WT4***2	WT4***3
Network Module Data Allocation Mode*1		4, 8, 16	4, 8, 16	4, 8	4, 8, 16

n = I/O address on the installation base

Factory setting = 1 kWh per bit.

Data address depends upon the data allocation mode as indicated below:

- 4 (n thr. n+3)
- 8 (n thr. n+7)
- 16 (n thr. n+15)

\*1. Fixed at 16 for the R3-NPx.

**I/O DATA DESCRIPTIONS**

■ 16-BIT DATA

16-bit binary data. Minus values are represented in 2's complements.

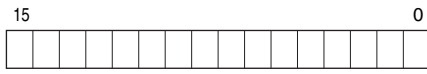

■ 32-BIT DATA

32-bit binary data. Minus values are represented in 2's complements.

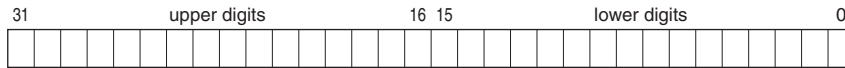

**EXTERNAL DIMENSIONS & TERMINAL ASSIGNMENTS unit: mm [inch]**

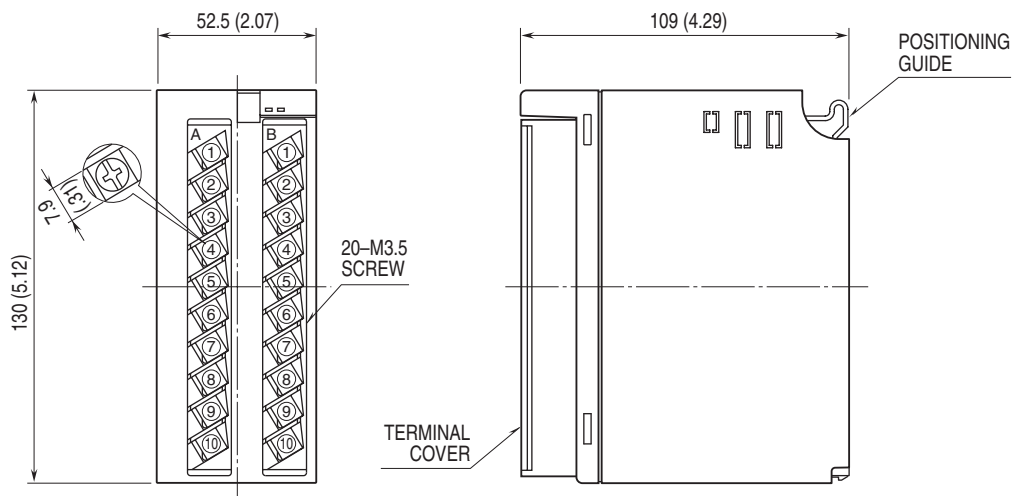

**SCHEMATIC CIRCUITRY & CONNECTION DIAGRAM**

■ 3-PHASE/3-WIRE

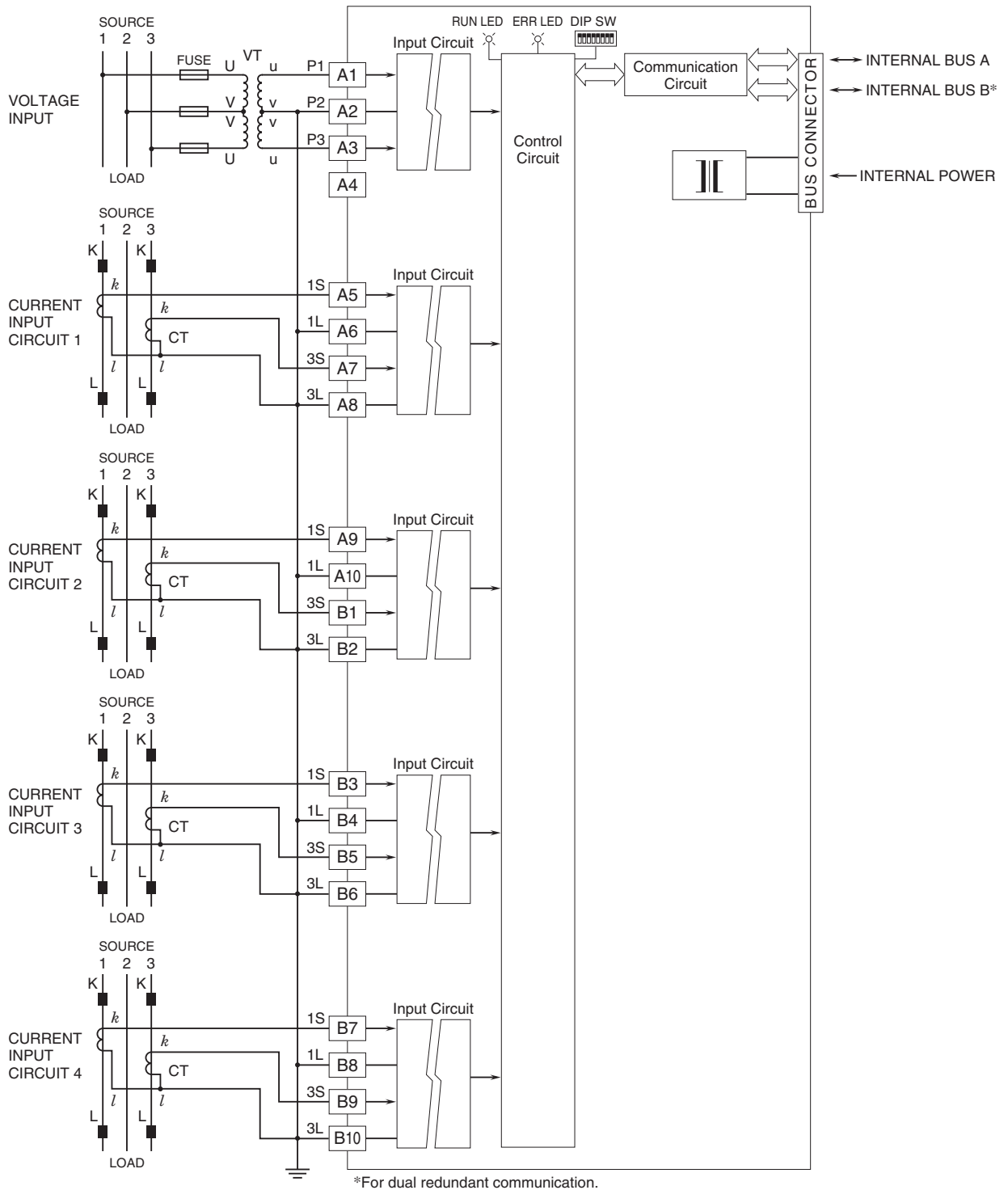

## ■ SINGLE-PHASE/2-WIRE

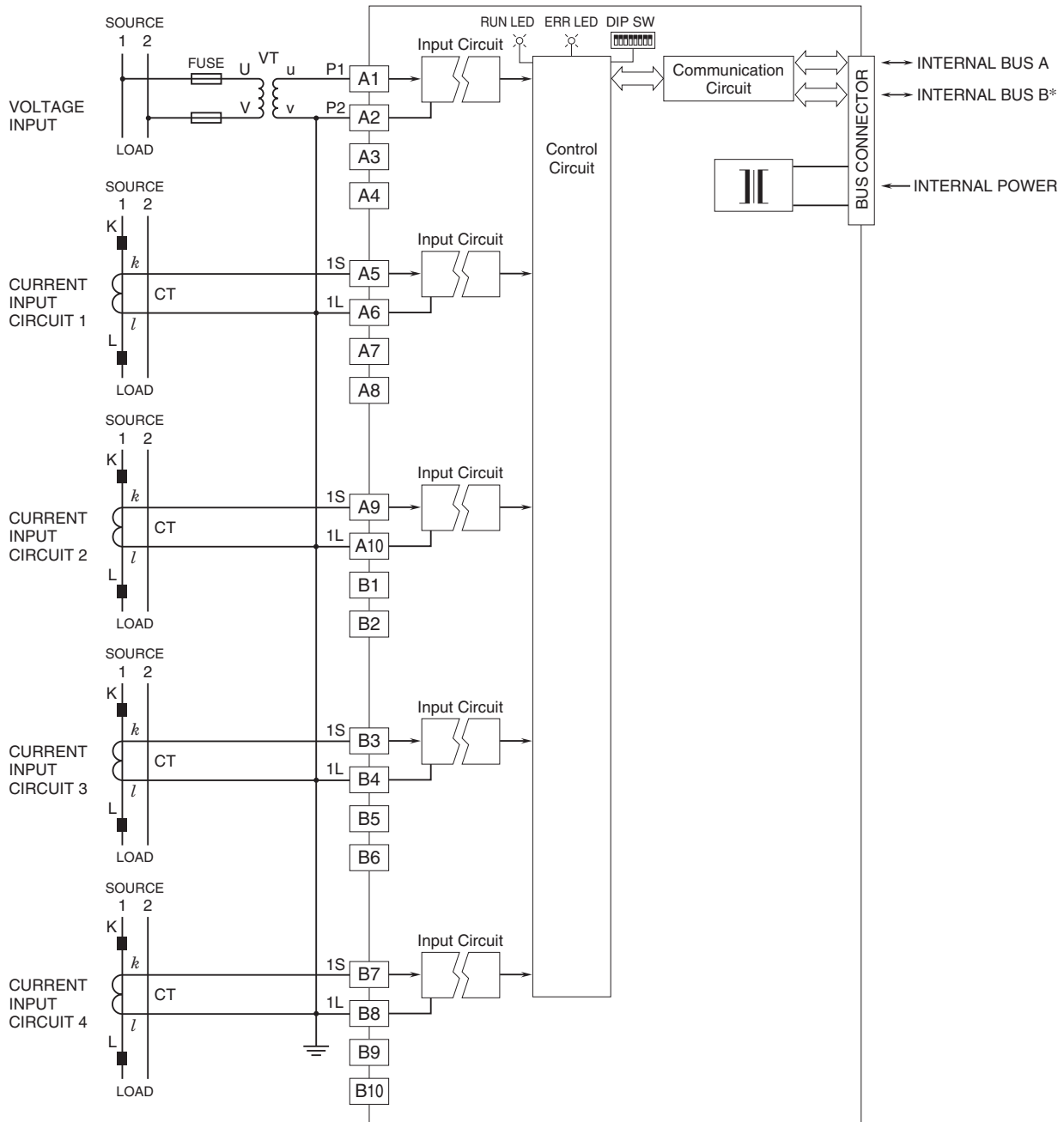

\*For dual redundant communication.

■ SINGLE-PHASE/3-WIRE

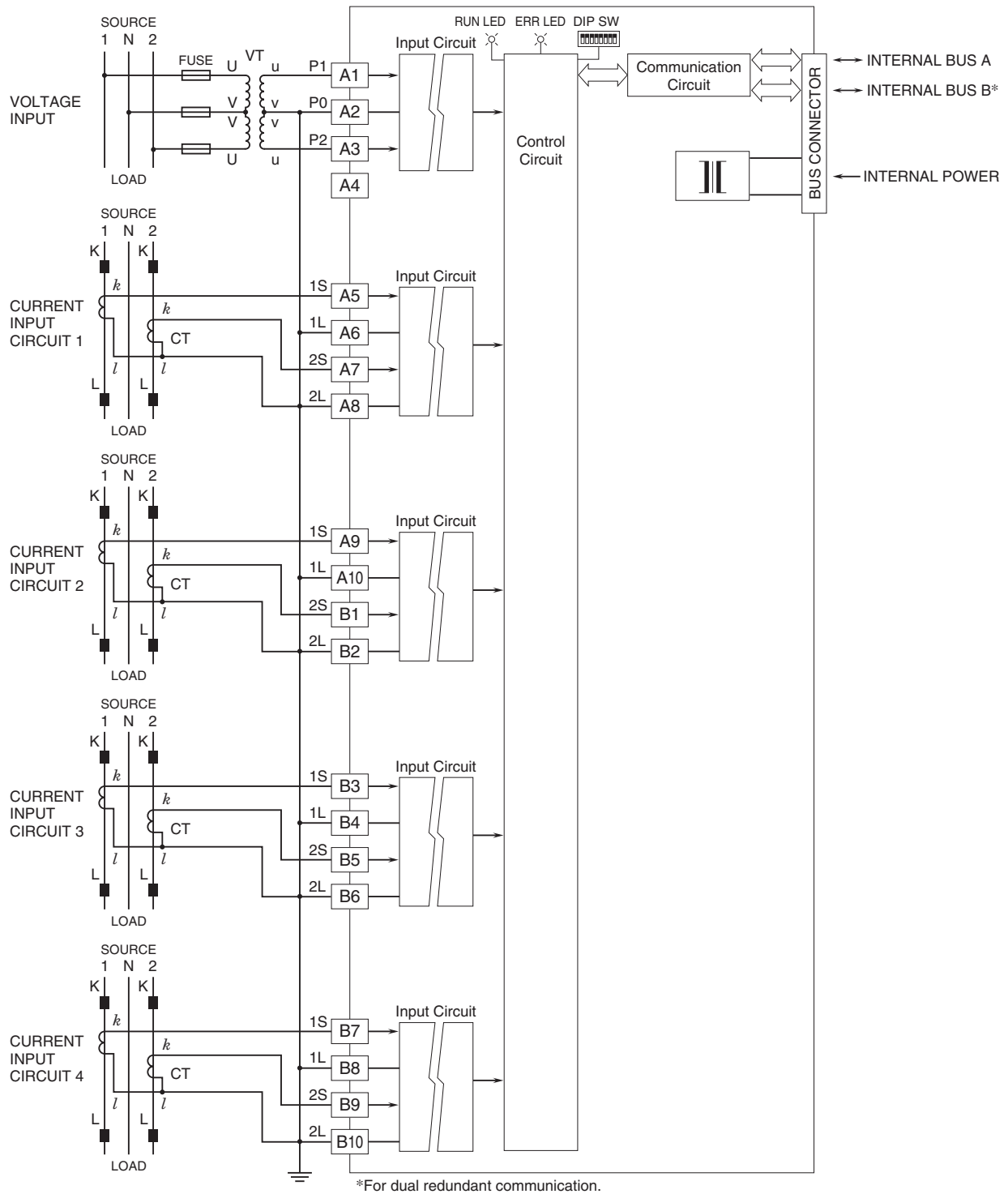

Specifications are subject to change without notice.