

Remote I/O R5 Series

PROFIBUS-DP INTERFACE MODULE

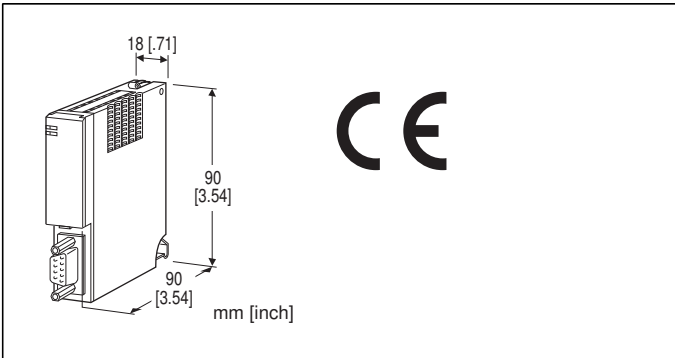

MODEL: R5-NP1[1]

ORDERING INFORMATION

- Code number: R5-NP1[1]
Specify a code from below for [1].
(e.g. R5-NP1/Q)
- Specify the specification for option code /Q
(e.g. /C01)

[1] OPTIONS

blank: none

/Q: With options (specify the specification)

SPECIFICATIONS OF OPTION: Q

COATING (For the detail, refer to our web site.)

/C01: Silicone coating

/C02: Polyurethane coating

/C03: Rubber coating

RELATED PRODUCTS

- PC configurator software (model: R5CON)
 - GSD (General Station Description) file
- The GSD file and configurator software are downloadable at our web site.
- A dedicated cable is required to connect the module to the PC. Please refer to the internet software download site or the users manual for the PC configurator for applicable cable types.

GENERAL SPECIFICATIONS

Connection

PROFIBUS: 9-pin D-sub connector, female
(Lock screw No. 4-40 UNC)

Internal bus: Via the Installation Base (model: R5-BS)

Internal power: Via the base (model: R5-BS)

Isolation: PROFIBUS to internal bus or internal power
RUN indicator: Bi-color (green/red) LED (refer to the instruction manual)

ERR indicator: Bi-color (green/red) LED (refer to the instruction manual)

Data allocation: Mode 1 or 2 set with the side DIP switch

PROFIBUS COMMUNICATION

Interface: PROFIBUS-DP, slave (RS-485 isolation)

Max. baud rate: 12 Mbps

Transmission cable: Approved for PROFIBUS-DP

Station address setting: Rotary switch; 00 - 7E
(The station address is programmed to 7E if a larger number is set on the switches.)

- Sync Mode, Freeze Mode are not supported.
 - Special Clear Mode (Fail Safe Mode) is not supported.
- However, when the R5-NP1 is initialized (when the power is turned on), the output of connected output modules is cleared by value "0": the discrete outputs are turned off; the analog outputs are reset to 0 %.

INSTALLATION

Operating temperature: -10 to +55°C (14 to 131°F)

Operating humidity: 30 to 90 %RH (non-condensing)

Atmosphere: No corrosive gas or heavy dust

Mounting: Installation Base (model: R5-BS)

Weight: 100 g (0.22 lb)

PERFORMANCE

Insulation resistance: $\geq 100 \text{ M}\Omega$ with 500 V DC

Dielectric strength: 2000 V AC @1 minute (PROFIBUS to internal bus or internal power)

STANDARDS & APPROVALS

EU conformity:

EMC Directive

EMI EN 61000-6-4

EMS EN 61000-6-2

RoHS Directive

EXTERNAL VIEW

■ SIDE VIEW

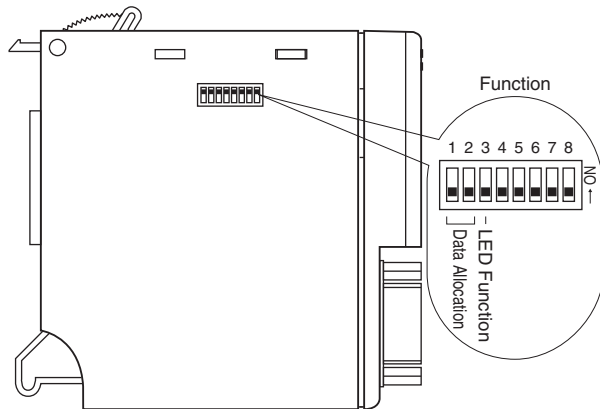

■ FRONT VIEW

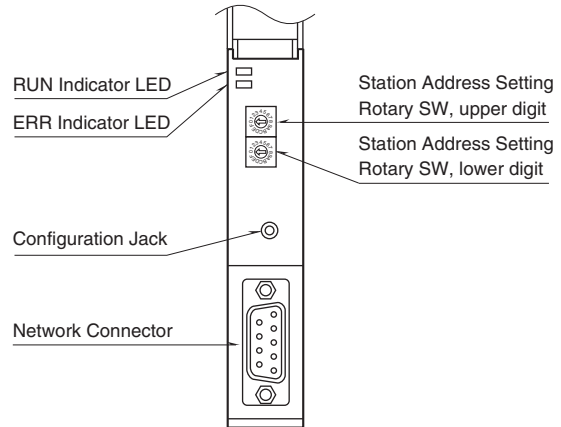

■ PROFIBUS INTERFACE



PIN No.	SIGNAL	SIGNIFICANCE
1	NC	Not used
2	NC	Not used
3	B_line	Network, B-line
4	RTS	RTS signal
5	GND	0V
6	P5V	5V
7	NC	Not used
8	A_line	Network, A-line
9	NC	Not used

TRANSMISSION DATA DESCRIPTIONS

The DIP SW located at the side of the module switches the unit's data allocation mode.

The Data Allocation Mode 1 is used when all analog I/O modules are single-channel types. In this mode, one (1) word is assigned for one I/O module. The second channel on the dual-channel modules cannot be used.

The Data Allocation Mode 2 is used when one or more analog I/O modules are dual-channel types. In this mode, two (2) words are assigned for one I/O module regardless of whether the second word area is required or not. For example, discrete I/O modules require only one (1) word, but two (2) words are automatically assigned to these modules.

■ I/O CAPACITY

In Data Allocation Mode 1, a maximum of 16 I/O modules can be mounted per node. If two-channel type analog modules are mixed, the second channel I/O cannot be used.

In Data Allocation Mode 2, a maximum of 8 I/O modules can be mounted per node.

■ DATA ALLOCATION MODE 1

•Output Data

The figure below shows the allocation of the data sent from the network module to the master.

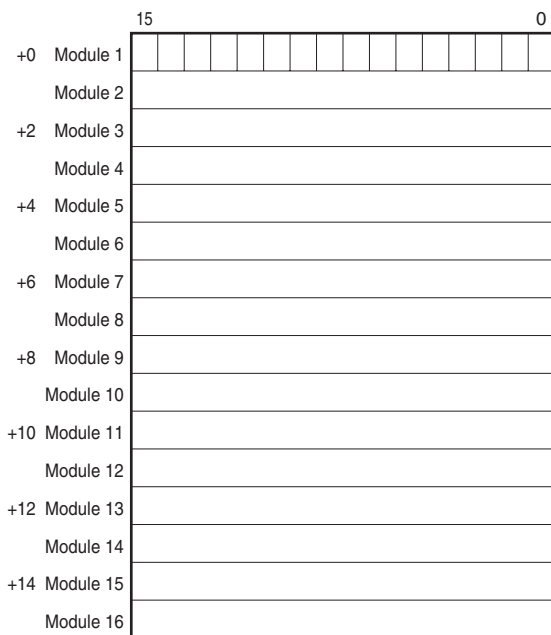

•Input Data

The figure below shows the allocation of the data sent from the master to the network module.

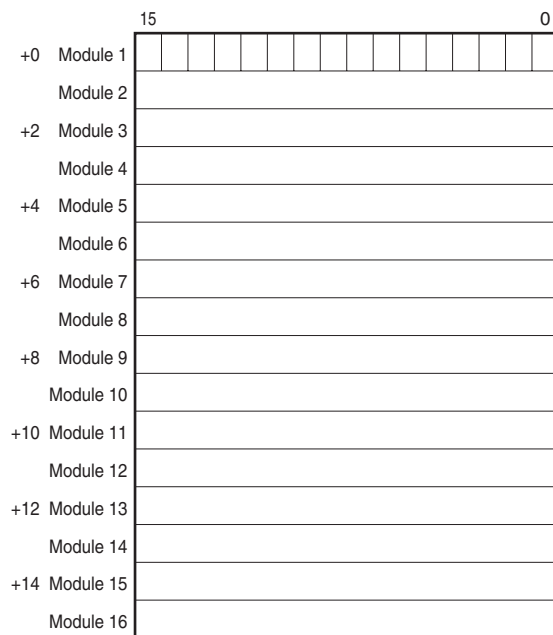

Each module takes one-word areas for input and output respectively, regardless of whether the module type is input or output. If a module for Data Allocation Mode 2 is used, the second channel data is not transmitted. An input module stores data in the output data area. The input data area is secured for the module but not used.

■ DATA ALLOCATION MODE 2

•Output Data

The figure below shows the allocation of the data sent from the network module to the master.

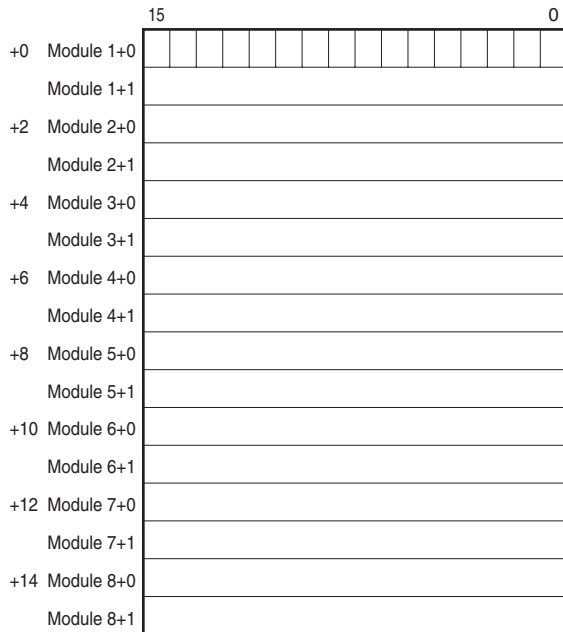

•Input Data

The figure below shows the allocation of the data sent from the master to the network module.

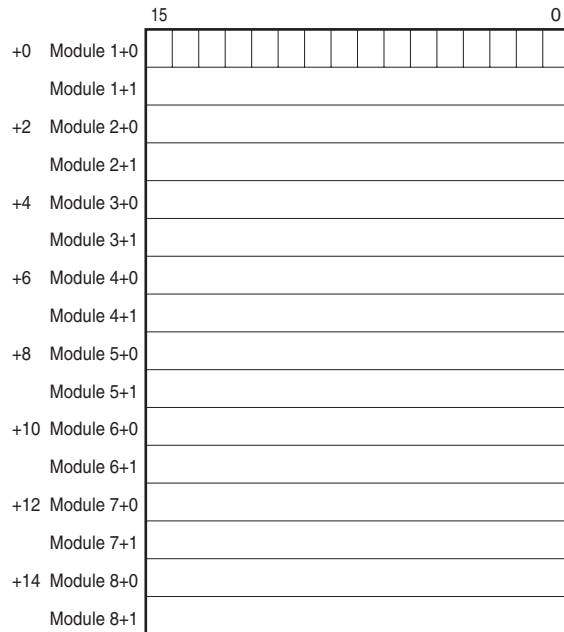

Each module takes two-word areas for input and output respectively, regardless of whether the module type is input or output. If a module for Data Allocation Mode 1 is used, all the bits for Module n+1 data turn to "0" (unused).

An input module stores data in the output data area. The input data area is secured for the module but not used.

I/O DATA DESCRIPTIONS

The data allocations for typical I/O modules are shown below.

Refer to the manual for each module for detailed data allocations.

■ANALOG 16 BITS DATA

0 to 100% of the selected I/O range is converted into 0 to 10000 (binary).

With °C or Kelvin temperature unit, raw data is multiplied by 10. For example, 25.5°C is converted into 255.

With °F temperature unit, the integer section of raw data is directly converted into the data. For example, 135.4°F is converted into 135.

Negative values are represented in 2's complements.

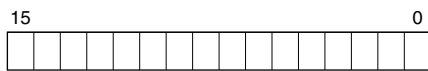

■ 16-POINT DISCRETE DATA

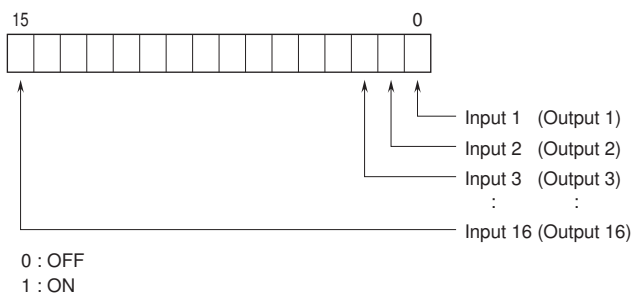

4-POINT DISCRETE DATA

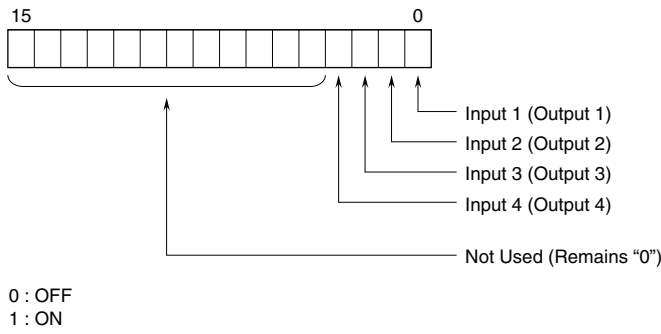

EXTERNAL DIMENSIONS unit: mm [inch]

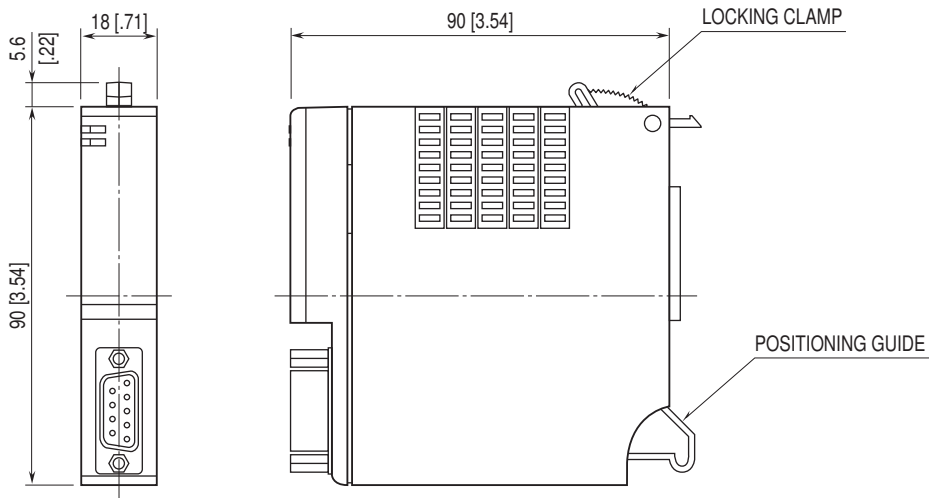

SCHEMATIC CIRCUITRY & CONNECTION DIAGRAM

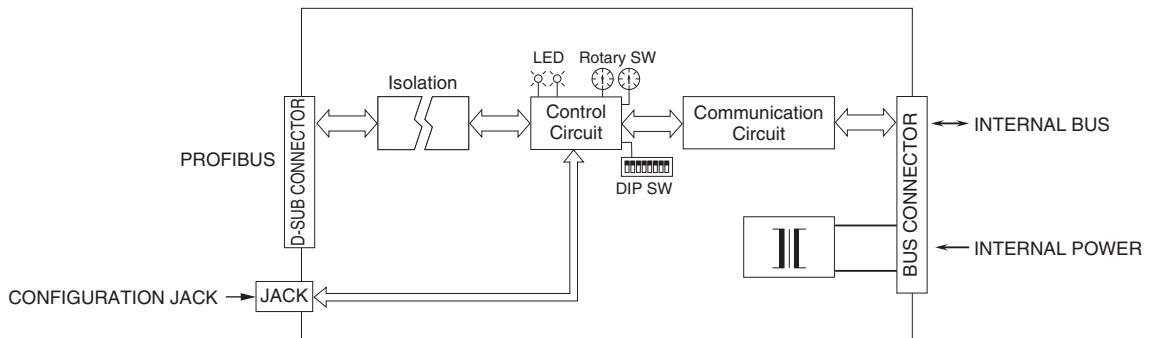

Specifications are subject to change without notice.