

Remote I/O R7 Series

DeviceNet® I/O MODULE

(PNP transistor output, 16 points)

Functions & Features

- 16 points PNP transistor output module for DeviceNet
- Extension module can be connected

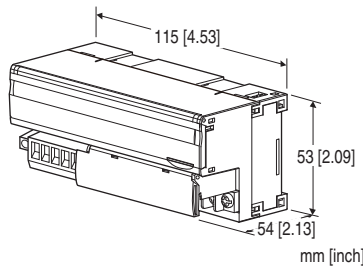

MODEL:R7D-DC16B[1]

ORDERING INFORMATION

- Code number: R7D-DC16B[1]
- Specify a code from below for [1].
(e.g. R7D-DC16B/Q)
- Specify the specification for option code /Q
(e.g. /C01/SET)

I/O TYPE

DC16B: PNP transistor output, 16 points

[1] OPTIONS

blank: none

/Q: With options (specify the specification)

SPECIFICATIONS OF OPTION: Q (multiple selections)

COATING (For the detail, refer to our web site.)

/C01: Silicone coating

/C02: Polyurethane coating

/C03: Rubber coating

EX-FACTORY SETTING

/SET: Preset according to the Ordering Information Sheet
(No. ESU-7802-G)

RELATED PRODUCTS

- PC Configurator cable (model: MCN-CON or COP-US)
- PC configurator software (model: R7CON)
- EDS file

The EDS files and configurator software are downloadable at our web site.

(Extension modules are registered in the EDS file as a combination of a basic module)

- Discrete input extension module (model: R7D-EAx)
- Discrete output extension module (model: R7D-ECx)

GENERAL SPECIFICATIONS

Connection

DeviceNet: Euro type connector terminal

(applicable wire size: 0.2 to 2.5 mm², stripped length 7 mm)

Output: M3 separable screw terminal (torque 0.5 N·m)

Solderless terminal: Refer to the drawing at the end of the section.

Recommended manufacturer: Japan Solderless Terminal MFG. Co., Ltd., Nichifu Co., Ltd.

Applicable wire size: 0.25 to 1.65 mm² (AWG 22 to 16)

Screw terminal: Nickel-plated steel

Housing material: Flame-resistant resin (gray)

Isolation: Output to DeviceNet

Extension: No extension (*), Discrete input 8 or 16 points,

Discrete output 8 or 16 points

Selectable with the front DIP SW

(* Factory default setting)

Output at the loss of communication:

Hold the output (*), Reset the output

Selectable with the front DIP SW

(* Factory default setting)

Discrete output status indicator LED: LED turns on with output ON

Configurator connection: 2.5 dia. miniature jack

■ Recommended solderless terminal

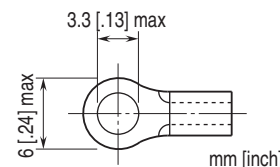

DeviceNet COMMUNICATION

Network cable: Approved for DeviceNet

Baud rate setting: 125 kbps (default), 250 kbps, 500 kbps, auto-tracking (rotary switch)

(Refer to the instruction manual.)

Status indicator LEDs: MS, NS

(Refer to the instruction manual for details.)

Node address setting: 1 - 63 (rotary switch, default:00)

(Refer to the instruction manual.)

Communication: Supports poll and cyclic

(Bit-strobe and COS (change of state) are not supported)

OUTPUT SPECIFICATIONS

Common: Positive common (PNP) per 16 points
Maximum outputs applicable at once: No limit (at 24 V DC)
Rated load voltage: 24 V DC $\pm 10\%$
Rated output current: 0.25 A per point, 2.0 A per common
Residual voltage: ≤ 1.2 V
Leakage current: ≤ 0.1 mA
ON delay: ≤ 0.5 msec.
OFF delay: ≤ 1.5 msec.
(When driving an inductive load, connect a diode in parallel with the load.)

INSTALLATION

Supply voltage to network: 11 - 25 V DC supplied through the network terminal block
Current Consumption:
Approx. 50 mA @ 24 V DC
Approx. 90 mA @ 11 V DC
Operating temperature: -10 to +55°C (14 to 131°F)
Storage temperature: -20 to +65°C (-4 to +149°F)
Operating humidity: 30 to 90 %RH (non-condensing)
Atmosphere: No corrosive gas or heavy dust
Mounting: DIN rail (35 mm rail)
Weight: 200 g (0.44 lb)

PERFORMANCE

Insulation resistance: ≥ 100 M Ω with 500 V DC
Dielectric strength: 1500 V AC @ 1 minute (output to DeviceNet)

STANDARDS & APPROVALS

EU conformity:
EMC Directive
EMI EN 61000-6-4
EMS EN 61000-6-2
RoHS Directive

EXTERNAL VIEW

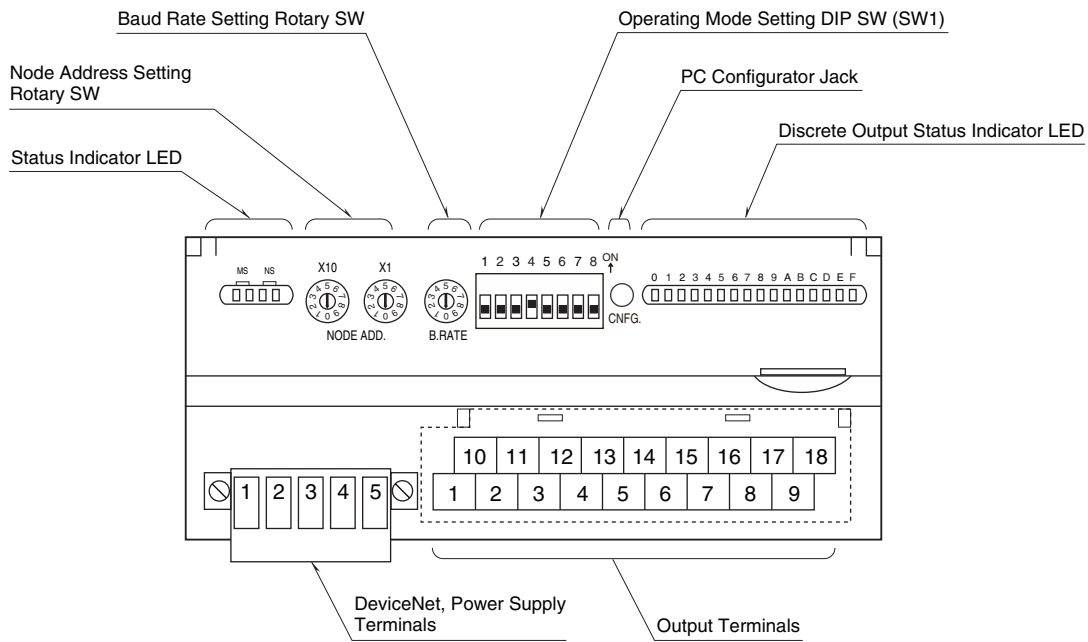

TERMINAL ASSIGNMENTS

■ OUTPUT TERMINAL ASSIGNMENT

10	11	12	13	14	15	16	17	18
+24V	Y1	Y3	Y5	Y7	Y9	YB	YD	YF
1	2	3	4	5	6	7	8	9
0V	Y0	Y2	Y4	Y6	Y8	YA	YC	YE

NO.	ID	FUNCTION	NO.	ID	FUNCTION
1	0V	0V	10	+24V	24V DC (common)
2	Y0	Output 0	11	Y1	Output 1
3	Y2	Output 2	12	Y3	Output 3
4	Y4	Output 4	13	Y5	Output 5
5	Y6	Output 6	14	Y7	Output 7
6	Y8	Output 8	15	Y9	Output 9
7	YA	Output 10	16	YB	Output 11
8	YC	Output 12	17	YD	Output 13
9	YE	Output 14	18	YF	Output 15

■ DeviceNet TERMINAL ASSIGNMENT

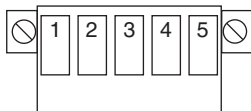

PIN NO.	COLOR	ID	FUNCTION
1	Red	V+	Network power supply +
2	White	CAN_H	Network data High
3	—	Drain	Shield
4	Blue	CAN_L	Network data Low
5	Black	V-	Network power supply -

DATA ALLOCATION

'Begin' address is determined by the R7D's node address and the master setting.

• **Example 1. R7D-DC16x, without Status**

Output Data
None

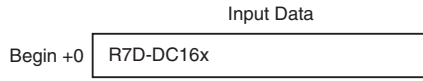

• **Example 2. R7D-DC16x, with Status**

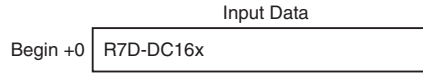
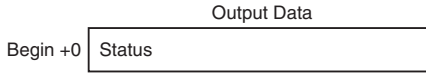

• **Example 3. R7D-DC16x + R7D-EA16, with Status**

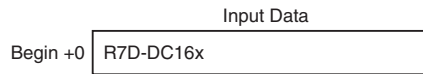
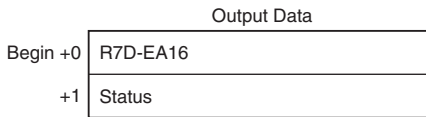

• **Example 4. R7D-DC16x + R7D-EC16x, with Status**

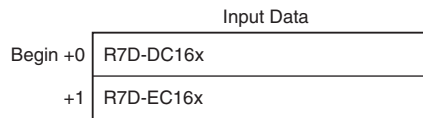
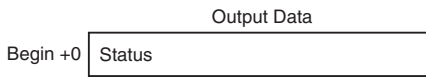

I/O DATA DESCRIPTIONS

■ DISCRETE I/O

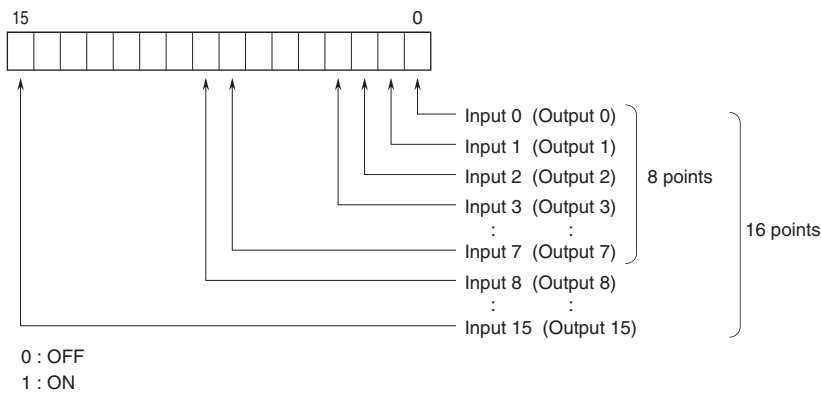

■ STATUS

Bit 0 to 7: Discrete output module shows '0' at the same address.

Bit 8 to 10: Shows the power supply status.

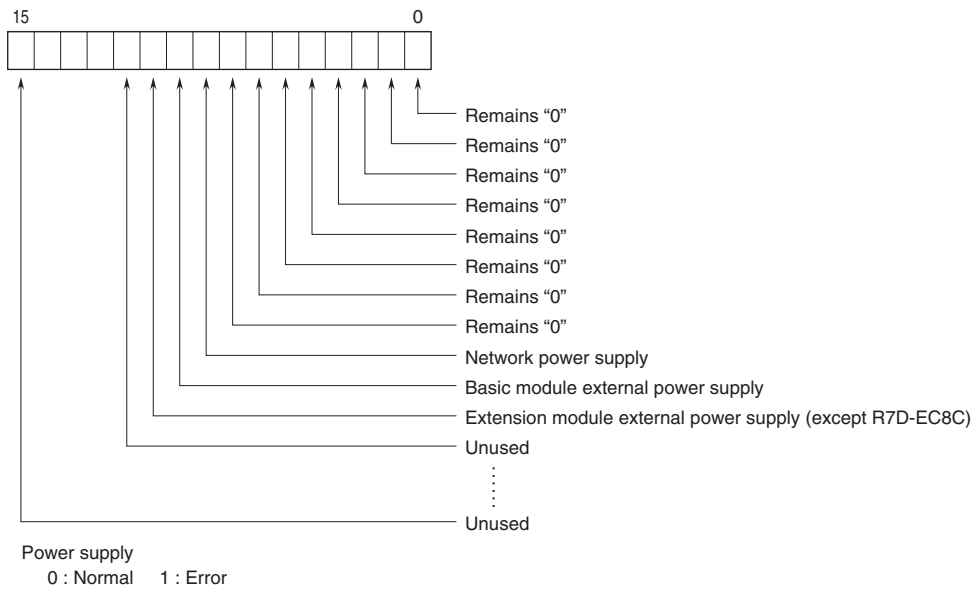

TRANSMISSION DATA DESCRIPTIONS

■ BASIC MODULE

Transmitted data (word) depends upon the modules types.

MODEL	OUTPUT DATA* ¹	INPUT DATA* ²
	(R7D to Master)	(Master to R7D)
R7D-DC16x	0	1

■ EXTENSION MODULE

Transmitted data (word) for the extension module is added.

MODEL	OUTPUT DATA* ¹	INPUT DATA* ²
	(R7D to Master)	(Master to R7D)
R7D-EAx	1	0
R7D-ECx	0	1

■ STATUS

Status signal can be included in the transmission data when the setting is enabled using the PC Configurator software (model: R7CON). For details, refer to "STATUS in I/O DATA DESCRIPTIONS".

STATUS	OUTPUT DATA* ¹	INPUT DATA* ²
	(R7D to Master)	(Master to R7D)
Enabled	1	0
Disabled	0	0

*1. Output Data means those sent to the master.

*2. Input Data means those received from the master.

EXTERNAL DIMENSIONS & TERMINAL ASSIGNMENTS unit: mm [inch]

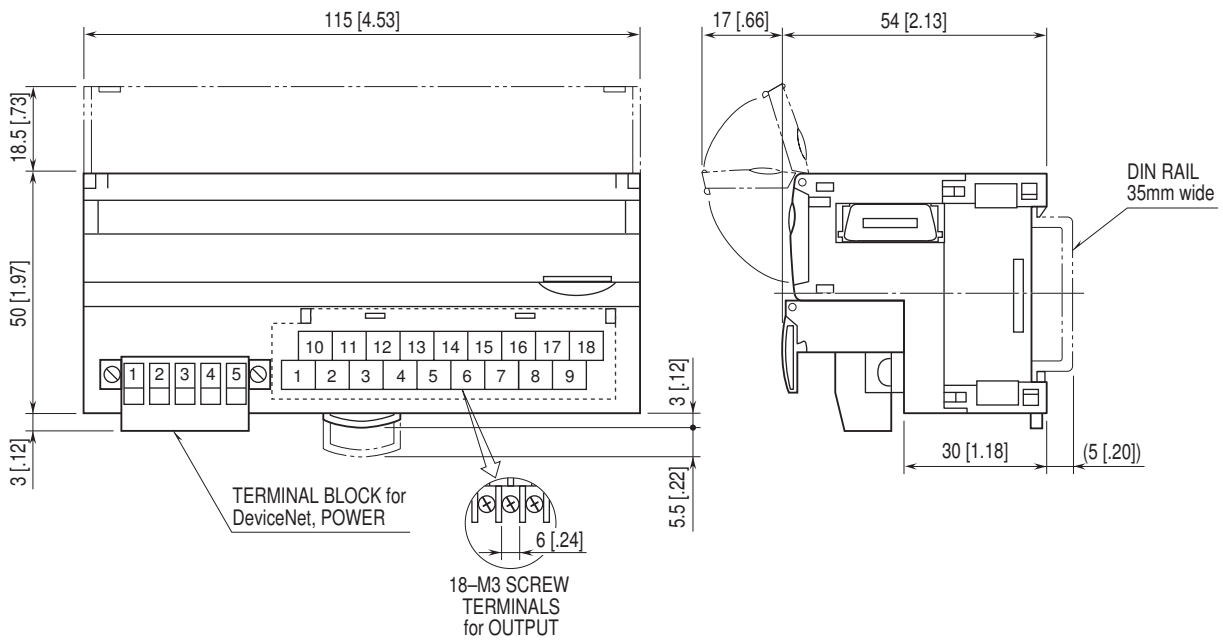

SCHEMATIC CIRCUITRY & CONNECTION DIAGRAM

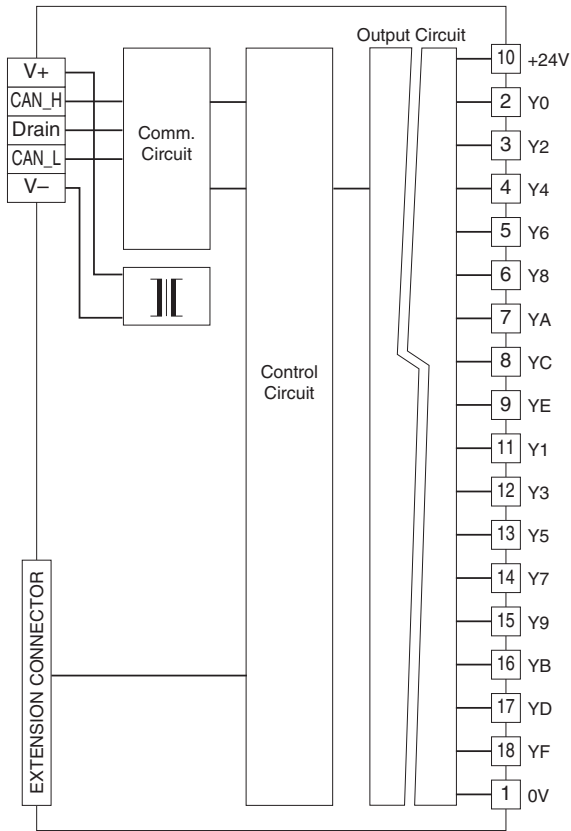

■ **Output Circuit**

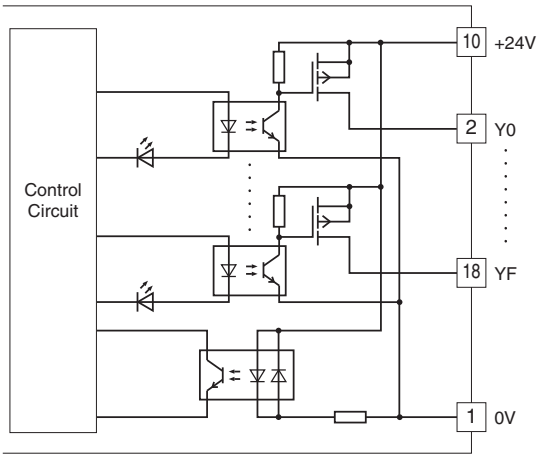

■ **Output Connection Example**

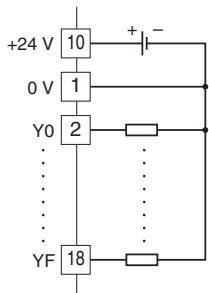



Specifications are subject to change without notice.