

Remote I/O R7 Series

DeviceNet® I/O MODULE

(relay contact output, 8 points, extension module available)

Functions & Features

- 8 points relay contact output module for DeviceNet
- Extension module can be connected

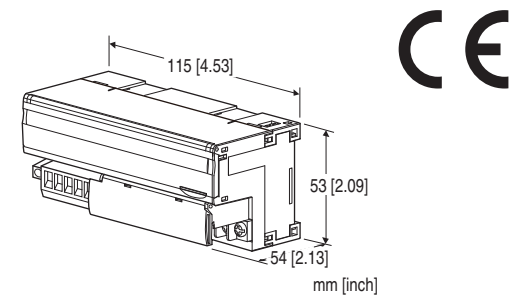

MODEL:R7D-DC8E[1]

ORDERING INFORMATION

- Code number: R7D-DC8E[1]
- Specify a code from below for [1].
(e.g. R7D-DC8E/Q)
- Specify the specification for option code /Q
(e.g. /C01/SET)

I/O TYPE

DC8E: Relay contact output, 8 points

[1] OPTIONS

blank: none

/Q: With options (specify the specification)

SPECIFICATIONS OF OPTION: Q (multiple selections)

COATING (For the detail, refer to our web site.)

- /C01: Silicone coating
- /C02: Polyurethane coating
- /C03: Rubber coating

EX-FACTORY SETTING

/SET: Preset according to the Ordering Information Sheet
(No. ESU-7802-G)

RELATED PRODUCTS

- PC Configurator cable (model: MCN-CON or COP-US)
- PC configurator software (model: R7CON)
- EDS file

The EDS files and configurator software are downloadable at our web site.

(Extension modules are registered in the EDS file as a combination of a basic module)

- Discrete input extension module (model: R7D-EAx)
- Discrete output extension module (model: R7D-ECx)

GENERAL SPECIFICATIONS

Connection

DeviceNet: Euro type connector terminal

(applicable wire size: 0.2 to 2.5 mm², stripped length 7 mm)

Output: M3 separable screw terminal (torque 0.5 N·m)

Solderless terminal: Refer to the drawing at the end of the section.

Recommended manufacturer: Japan Solderless Terminal MFG. Co., Ltd., Nichifu Co., Ltd.

Applicable wire size: 0.25 to 1.65 mm² (AWG 22 to 16)

Screw terminal: Nickel-plated steel

Housing material: Flame-resistant resin (gray)

Isolation: Output to DeviceNet

Extension: No extension (*), Discrete input 8 or 16 points,

Discrete output 8 or 16 points

Selectable with the front DIP SW

(* Factory default setting)

Output at the loss of communication:

Hold the output (*), Reset the output

Selectable with the front DIP SW

(* Factory default setting)

Discrete output status indicator LED: LED turns on with output ON

Configurator connection: 2.5 dia. miniature jack

■ Recommended solderless terminal

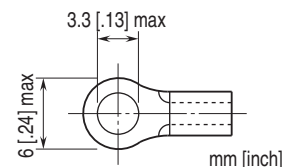

DeviceNet COMMUNICATION

Network cable: Approved for DeviceNet

Baud rate setting: 125 kbps (default), 250 kbps, 500 kbps, auto-tracking (rotary switch)

(Refer to the instruction manual.)

Status indicator LEDs: MS, NS

(Refer to the instruction manual for details.)

Node address setting: 1 - 63 (rotary switch, default:00)

(Refer to the instruction manual.)

Communication: Supports poll and cyclic

(Bit-strobe and COS (change of state) are not supported)

OUTPUT SPECIFICATIONS

Common: 1 common per 4 points (4 terminals)
Maximum load current: 2.0 A per point
Common current: Max. 8 A (4 terminals total)
Maximum outputs applicable at once: No limit (at 24 V DC)
Output supply voltage/current: 24 V DC $\pm 10\%$ / approx. 40 mA
Rated load: 250 V AC¹ @ 2 A ($\cos \phi = 1$)
30 V DC @ 2 A (resistive load)
Electrical life 10^5 cycles (rate 30/min.)
*1. When it is used as a product relevant to EU directive, it should be used under the Installation Category I, 125 V AC or less.
Maximum switching voltage: 250 V AC, 30 V DC
Maximum switching power: 500 VA (AC), 60 W (DC)
Minimum applicable load: 24 V DC @ 5 mA
Mechanical life: 2×10^7 cycles (300 cycles per min.)
When driving an inductive load, external contact protection and noise quenching recommended.
ON delay time: ≤ 10 msec.
OFF delay time: ≤ 10 msec.

Output to communication: Basic insulation (150 V)
RoHS Directive

INSTALLATION

Supply voltage to network: 11 - 25 V DC supplied through the network terminal block
Current Consumption:
Approx. 40 mA @ 24 V DC
Approx. 70 mA @ 11 V DC
Relay driving current: Approx. 40 mA
Operating temperature: -10 to +55°C (14 to 131°F)
Storage temperature: -20 to +65°C (-4 to +149°F)
Operating humidity: 30 to 90 %RH (non-condensing)
Atmosphere: No corrosive gas or heavy dust
Mounting: DIN rail (35 mm rail)
Weight: 180 g (0.40 lb)

PERFORMANCE

Insulation resistance: ≥ 100 M Ω with 500 V DC
Dielectric strength: 1500 V AC @ 1 minute (output to DeviceNet)

STANDARDS & APPROVALS

Refer to the manuals to comply with the standards.

EU conformity:

EMC Directive
EMI EN 61000-6-4
EMS EN 61000-6-2
Low Voltage Directive
EN 61010-1, EN 61010-2-201
Measurement Category II (output)
Pollution Degree 2

EXTERNAL VIEW

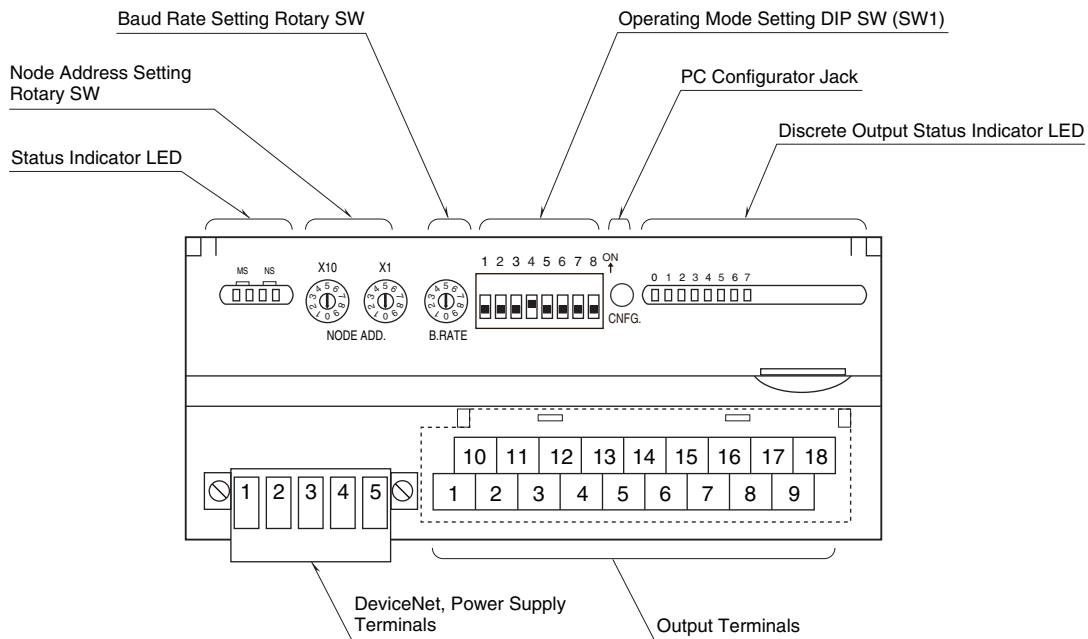

TERMINAL ASSIGNMENTS

■ OUTPUT TERMINAL ASSIGNMENT

| | | | | | | | | |
|------|------|------|------|------|------|------|------|------|
| 10 | 11 | 12 | 13 | 14 | 15 | 16 | 17 | 18 |
| +24V | Y0 | Y1 | Y2 | Y3 | Y4 | Y5 | Y6 | Y7 |
| 1 | 2 | 3 | 4 | 5 | 6 | 7 | 8 | 9 |
| 0V | COM0 | COM0 | COM0 | COM0 | COM1 | COM1 | COM1 | COM1 |

| NO. | ID | FUNCTION | NO. | ID | FUNCTION |
|-----|------|----------|-----|------|----------|
| 1 | 0V | 0V | 10 | +24V | 24V DC |
| 2 | COM0 | Common 0 | 11 | Y0 | Output 0 |
| 3 | COM0 | Common 0 | 12 | Y1 | Output 1 |
| 4 | COM0 | Common 0 | 13 | Y2 | Output 2 |
| 5 | COM0 | Common 0 | 14 | Y3 | Output 3 |
| 6 | COM1 | Common 1 | 15 | Y4 | Output 4 |
| 7 | COM1 | Common 1 | 16 | Y5 | Output 5 |
| 8 | COM1 | Common 1 | 17 | Y6 | Output 6 |
| 9 | COM1 | Common 1 | 18 | Y7 | Output 7 |

■ DeviceNet TERMINAL ASSIGNMENT

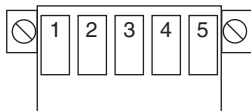

| PIN NO. | COLOR | ID | FUNCTION |
|---------|-------|-------|------------------------|
| 1 | Red | V+ | Network power supply + |
| 2 | White | CAN_H | Network data High |
| 3 | - | Drain | Shield |
| 4 | Blue | CAN_L | Network data Low |
| 5 | Black | V- | Network power supply - |

DATA ALLOCATION

'Begin' address is determined by the R7D's node address and the master setting.

• **Example 1. R7D-DC8E, without Status**

Output Data
None

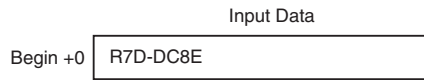

• **Example 2. R7D-DC8E, with Status**

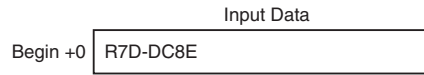
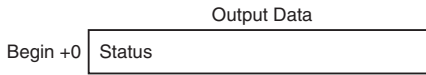

• **Example 3. R7D-DC8E + R7D-EA16, with Status**

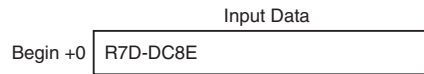
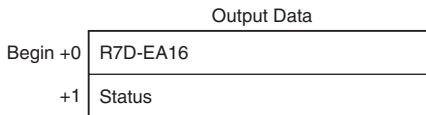

• **Example 4. R7D-DC8E + R7D-EC16x, with Status**

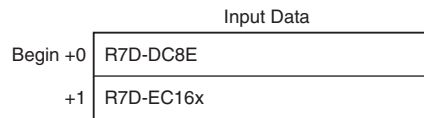
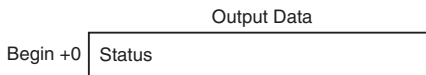

I/O DATA DESCRIPTIONS

■ DISCRETE I/O

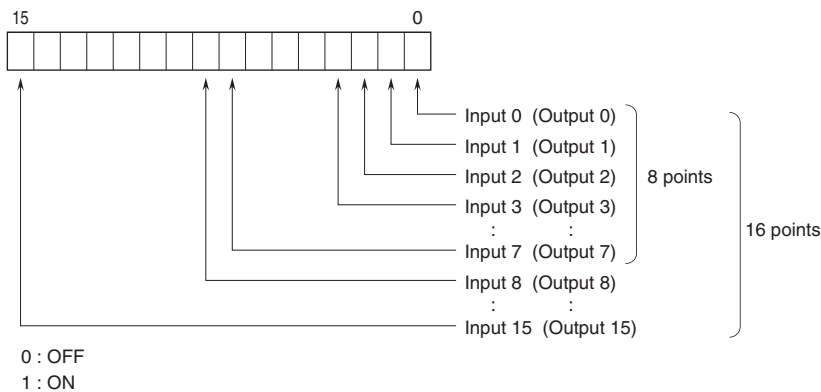

■ STATUS

Bit 0 to 7: Discrete output module shows '0' at the same address.

Bit 8 to 10: Shows the power supply status.

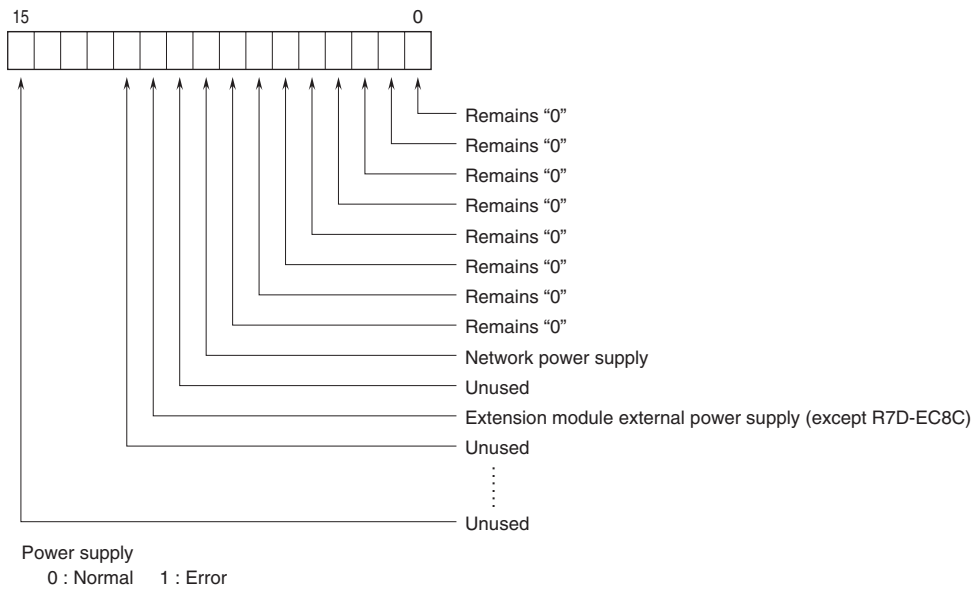

TRANSMISSION DATA DESCRIPTIONS

■ BASIC MODULE

Transmitted data (word) depends upon the modules types.

| MODEL | OUTPUT DATA* ¹ | INPUT DATA* ² |
|----------|---------------------------|--------------------------|
| | (R7D to Master) | (Master to R7D) |
| R7D-DC8E | 0 | 1 |

■ EXTENSION MODULE

Transmitted data (word) for the extension module is added.

| MODEL | OUTPUT DATA* ¹ | INPUT DATA* ² |
|---------|---------------------------|--------------------------|
| | (R7D to Master) | (Master to R7D) |
| R7D-EAx | 1 | 0 |
| R7D-ECx | 0 | 1 |

■ STATUS

Status signal can be included in the transmission data when the setting is enabled using the PC Configurator software (model: R7CON). For details, refer to "STATUS in I/O DATA DESCRIPTIONS".

| STATUS | OUTPUT DATA* ¹ | INPUT DATA* ² |
|----------|---------------------------|--------------------------|
| | (R7D to Master) | (Master to R7D) |
| Enabled | 1 | 0 |
| Disabled | 0 | 0 |

*1. Output Data means those sent to the master.

*2. Input Data means those received from the master.

EXTERNAL DIMENSIONS & TERMINAL ASSIGNMENTS unit: mm [inch]

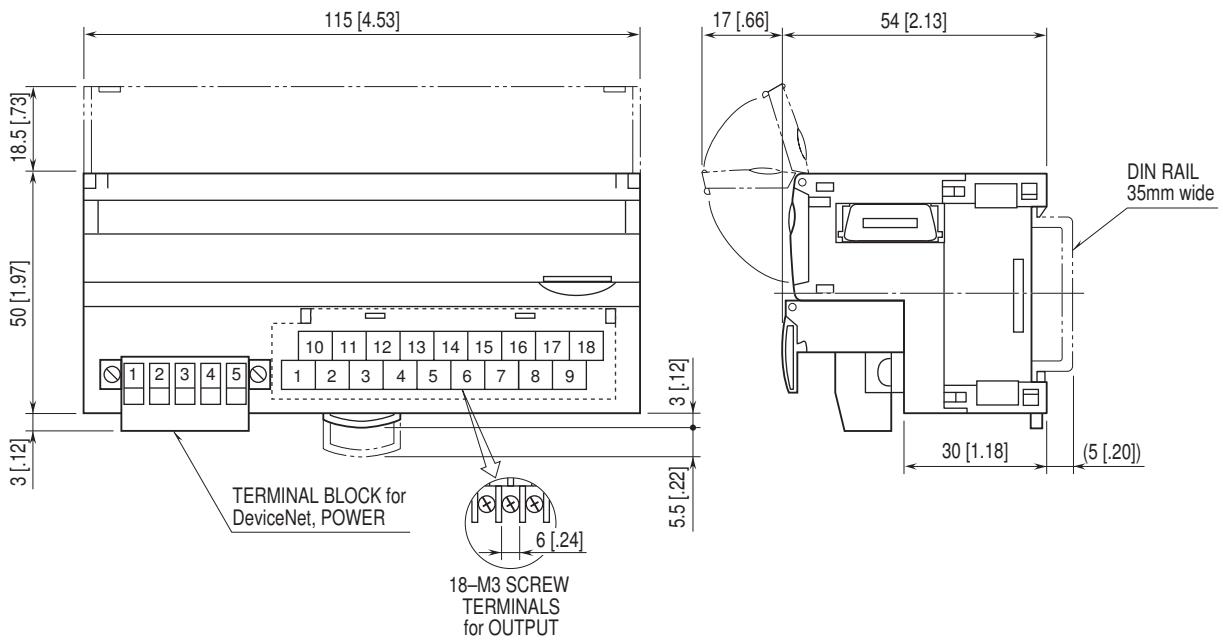

SCHEMATIC CIRCUITRY & CONNECTION DIAGRAM

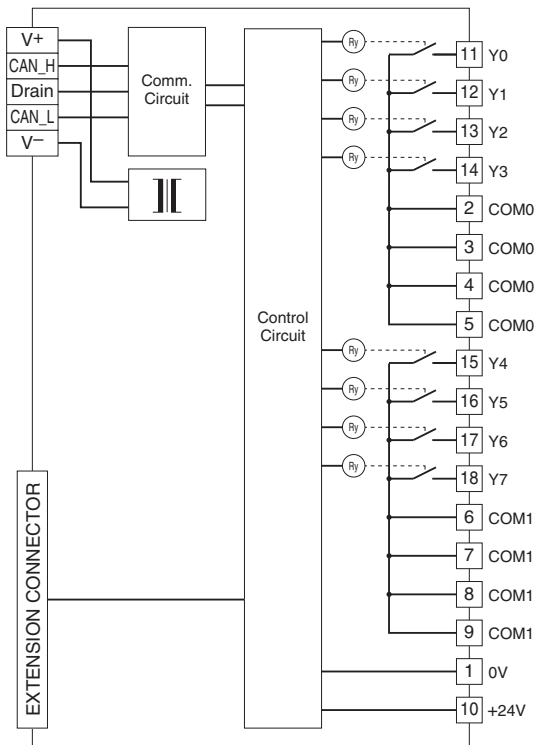

■ Output Connection Example

4 points / common

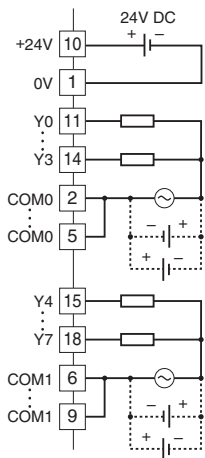

8 points / common

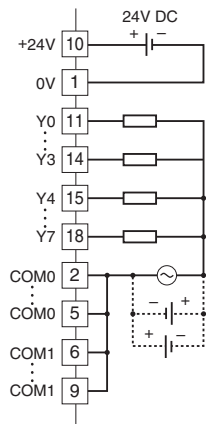

Specifications are subject to change without notice.