

## Remote I/O R7 Series

### DeviceNet® I/O MODULE

(RTD input, 4 points, isolated)

#### Functions & Features

- 4 points RTD input module for DeviceNet
- Extension module can be connected
- Input sensor type can be selected with the front DIP switches for all channels.
- Individual channels, zero adjustment, span adjustment, scaling, and temperature unit can be set with the configurator software (model: R7CON)

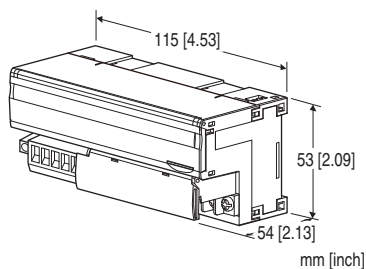

### MODEL:R7D-RS4[1]

#### ORDERING INFORMATION

- Code number: R7D-RS4[1]
- Specify a code from below for [1].  
(e.g. R7D-RS4/Q)
- Specify the specification for option code /Q  
(e.g. /C01/SET)

#### I/O TYPE

RS4: RTD input, 4 points

#### [1] OPTIONS

blank: none

/Q: With options (specify the specification)

#### SPECIFICATIONS OF OPTION: Q (multiple selections)

##### COATING (For the detail, refer to our web site.)

- /C01: Silicone coating
- /C02: Polyurethane coating
- /C03: Rubber coating

##### EX-FACTORY SETTING

/SET: Preset according to the Ordering Information Sheet  
(No. ESU-7802-C)

#### RELATED PRODUCTS

- PC Configurator cable (model: MCN-CON or COP-US)
- PC configurator software (model: R7CON)
- EDS file

The EDS files and configurator software are downloadable at our web site.

(Extension modules are registered in the EDS file as a combination of a basic module)

- Discrete input extension module (model: R7D-EAx)
- Discrete output extension module (model: R7D-ECx)

#### GENERAL SPECIFICATIONS

##### Connection

**DeviceNet:** Euro type connector terminal  
(applicable wire size: 0.2 to 2.5 mm<sup>2</sup>, stripped length 7 mm)

**Input:** M3 separable screw terminal (torque 0.5 N·m)

**Solderless terminal:** Refer to the drawing at the end of the section.

**Recommended manufacturer:** Japan Solderless Terminal MFG. Co., Ltd., Nichifu Co., Ltd.

**Applicable wire size:** 0.25 to 1.65 mm<sup>2</sup> (AWG 22 to 16)

**Screw terminal:** Nickel-plated steel

**Housing material:** Flame-resistant resin (gray)

**Isolation:** Input 0 to input 1 to input 2 to input 3 to DeviceNet

**Zero adjustments:** Configurable via R7CON

**Span adjustments:** Configurable via R7CON

**Extension:** No extension (\*), Discrete input 8 or 16 points, Discrete output 8 or 16 points

Selectable with the front DIP SW

(\* Factory default setting)

**Conversion rate:** Selectable with the front DIP SW

**Burnout setting:** Selectable between upscale (\*) and downscale with the front DIP switch

(\* Factory default setting)

**Linearization:** Standard

**RTD Setting:** Configurable via the front DIP switch or R7CON

**Configurator connection:** 2.5 dia. miniature jack

##### ■Recommended solderless terminal

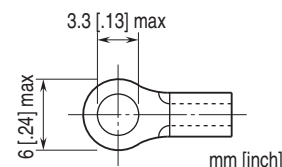

#### DeviceNet COMMUNICATION

**Network cable:** Approved for DeviceNet

**Baud rate setting:** 125 kbps (default), 250 kbps, 500 kbps, auto-tracking (rotary switch)

(Refer to the instruction manual.)

**Status indicator LEDs:** MS, NS

(Refer to the instruction manual for details.)

**Node address setting:** 1 - 63 (rotary switch, default:00)

(Refer to the instruction manual.)

**Communication:** Supports poll and cyclic

(Bit-strobe and COS (change of state) are not supported)

25°C

**Response time:** Conversion rate × 2 + 50 msec. (0 - 90 %)

**Insulation resistance:** ≥ 100 MΩ with 500 V DC

**Dielectric strength:** 1500 V AC @ 1 minute (input 0 to input 1 to input 2 to input 3 to DeviceNet)

## INPUT SPECIFICATIONS

**Input resistance:** ≥ 1 MΩ

**Maximum leadwire resistance:** 100 Ω per wire

**Sensing current:** ≤ 1 mA

RTD	BURNOUT INDICATION (°C)		CONFORMANCE RANGE (°C)
	Downscale	Upscale	
Pt 100 (JIS '97, IEC)	-240	+900	-200 to +850
Pt 100 (JIS '89)	-240	+900	-200 to +660
JPt 100 (JIS '89)	-236	+560	-200 to +510
Pt 50 Ω (JIS '81)	-236	+700	-200 to +649
Ni 100	-100	+252	-80 to +250
Cu 10 @ 25°C	-212	+312	-50 to +250
Cu 50	-100	+200	-50 to +150

RTD	BURNOUT INDICATION (°F)		CONFORMANCE RANGE (°F)
	Downscale	Upscale	
Pt 100 (JIS '97, IEC)	-400	+1652	-328 to +1562
Pt 100 (JIS '89)	-400	+1652	-328 to +1220
JPt 100 (JIS '89)	-393	+1040	-328 to +950
Pt 50 Ω (JIS '81)	-393	+1292	-328 to +1200
Ni 100	-148	+486	-112 to +482
Cu 10 @ 25°C	-350	+594	-58 to +482
Cu 50	-148	+392	-58 to +302

## STANDARDS & APPROVALS

**EU conformity:**

EMC Directive

EMI EN 61000-6-4

EMS EN 61000-6-2

RoHS Directive

## INSTALLATION

**Supply voltage to network:** 11 - 25 V DC supplied through the network terminal block

**Current Consumption:**

Approx. 60 mA @ 24 V DC

Approx. 110 mA @ 11 V DC

**Operating temperature:** -10 to +55°C (14 to 131°F)

**Storage temperature:** -20 to +65°C (-4 to +149°F)

**Operating humidity:** 30 to 90 %RH (non-condensing)

**Atmosphere:** No corrosive gas or heavy dust

**Mounting:** DIN rail (35 mm rail)

**Weight:** 200 g (0.44 lb)

## PERFORMANCE

**Conversion accuracy:** ±1°C (±1.8°F)

(±3°C [±5.4°F] for Cu 10 @ 25°C)

**Conversion rate:** 250 msec. (\*) or 500 msec. selectable

(\*) Factory default setting

**Converted data range:**

- Engineering unit value (°C, K) × 10 (integer)
- Engineering unit value (°F)

**Temperature coefficient:** ±0.015 %/°C (±0.008 %/°F) of max. span except ±0.150 %/°C (±0.08 %/°F) for Cu 10 @

## EXTERNAL VIEW

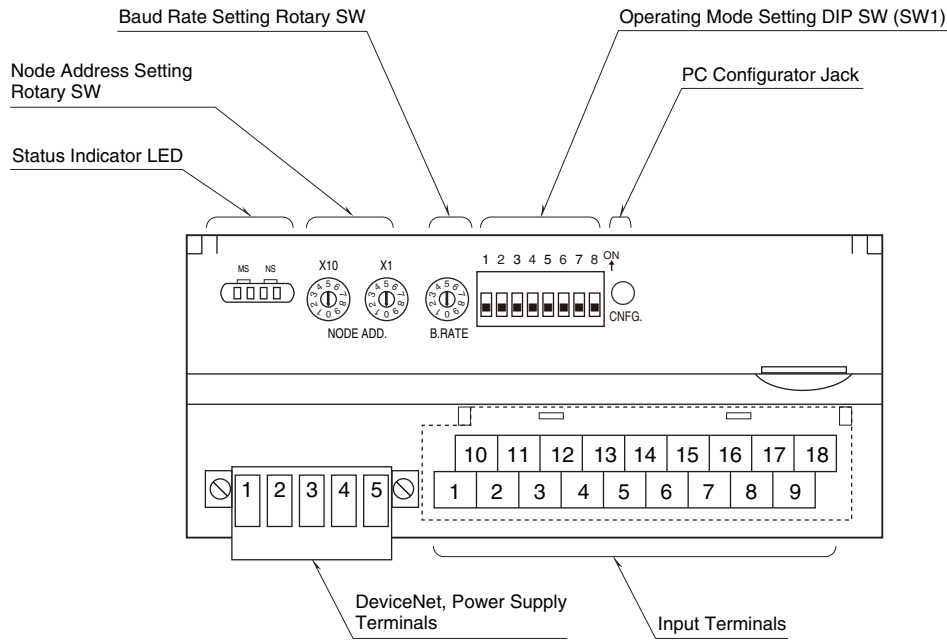

## TERMINAL ASSIGNMENTS

### INPUT TERMINAL ASSIGNMENT

10	11	12	13	14	15	16	17	18
INA0	INb0	INA1	INb1	NC	INA2	INb2	INA3	INb3
1	2	3	4	5	6	7	8	9
NC	INB0	NC	INB1	NC	NC	INB2	NC	INB3

NO.	ID	FUNCTION	NO.	ID	FUNCTION
1	NC	No connection	10	INA0	RTD 0-A
2	INB0	RTD 0-B	11	INb0	RTD 0-b
3	NC	No connection	12	INA1	RTD 1-A
4	INB1	RTD 1-B	13	INb1	RTD 1-b
5	NC	No connection	14	NC	No connection
6	NC	No connection	15	INA2	RTD 2-A
7	INB2	RTD 2-B	16	INb2	RTD 2-b
8	NC	No connection	17	INA3	RTD 3-A
9	INB3	RTD 3-B	18	INb3	RTD 3-b

### DeviceNet TERMINAL ASSIGNMENT

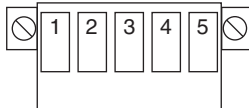

PIN NO.	COLOR	ID	FUNCTION
1	Red	V+	Network power supply +
2	White	CAN_H	Network data High
3	-	Drain	Shield
4	Blue	CAN_L	Network data Low
5	Black	V-	Network power supply -

## DATA CONVERSION

### ■ INPUT RANGE AND DATA CONVERSION (FACTORY DEFAULT SETTING)

Engineering unit value °C or K is multiplied by 10 and expressed in 16 bits. °F data is represented in engineering unit value, without multiplication. Negative value is represented in 2's complements.

• Input TYPE K Thermocouple

Input Value	Converted Data, Decimal	Converted Data, Hex
≤ -272°C	-2720	F560
-150°C	-1500	FA24
1370°C	13700	3584
≥ 1472°C	14720	3980

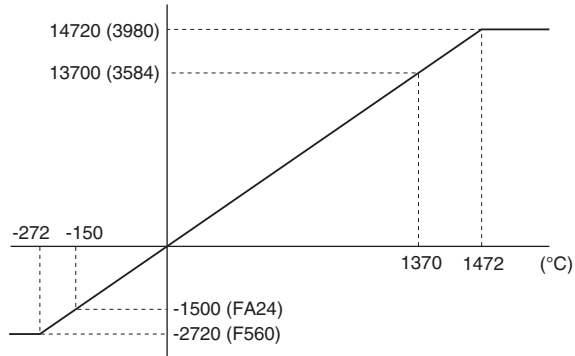

## DATA ALLOCATION

### • Example 1. Analog Input Module, without Status

Output Data		Input Data
Begin +0	Analog Input Module CH0	None
+1	CH1	
+2	CH2	
+3	CH3	

### • Example 2. Analog Input Module, with Status

Output Data		Input Data
Begin +0	Analog Input Module CH0	None
+1	CH1	
+2	CH2	
+3	CH3	
+4	Status	

### • Example 3. Analog Input Module + R7D-EA16, with Status

Output Data		Input Data
Begin +0	Analog Input Module CH0	None
+1	CH1	
+2	CH2	
+3	CH3	
+4	R7D-EA16	
+5	Status	

### • Example 4. Analog Input Module + R7D-EC16x, with Status

Output Data		Input Data
Begin +0	Analog Input Module CH0	R7D-EC16x
+1	CH1	
+2	CH2	
+3	CH3	
+4	Status	

**I/O DATA DESCRIPTIONS**

■ ANALOG INPUT

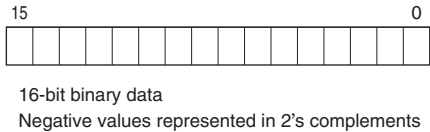

■ DISCRETE I/O

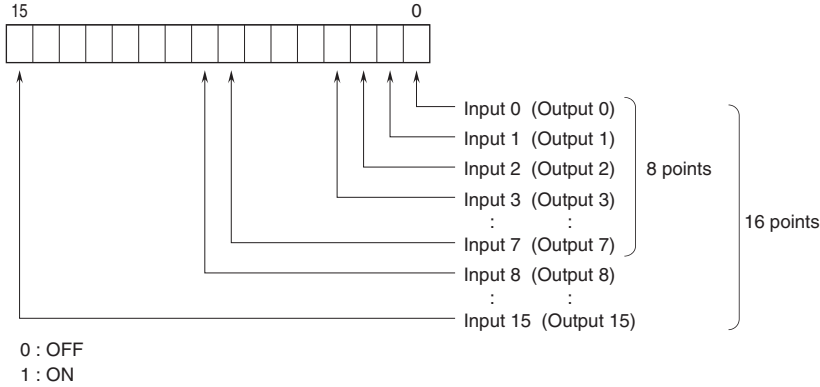

■ STATUS

Bit 0 to 7: Analog input modules can show input status of each channel.  
Bit 8 to 10: Shows the power supply status.

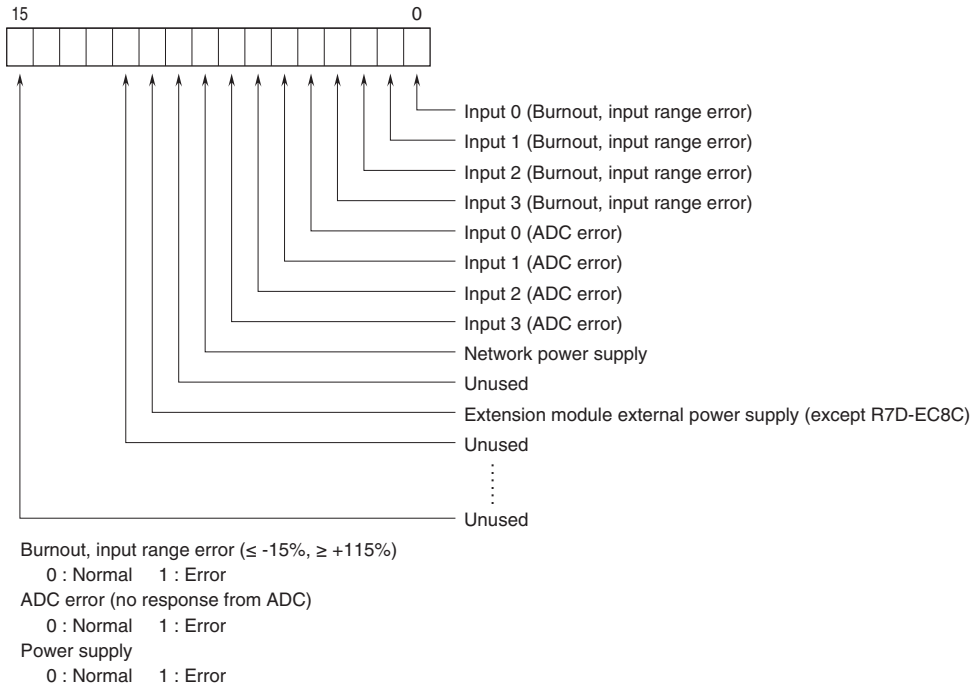

## TRANSMISSION DATA DESCRIPTIONS

### ■ BASIC MODULE

Transmitted data (word) depends upon the modules types.

MODEL	OUTPUT DATA* <sup>1</sup> (R7D to Master)	INPUT DATA* <sup>2</sup> (Master to R7D)
R7D-RS4	4	0

### ■ EXTENSION MODULE

Transmitted data (word) for the extension module is added.

MODEL	OUTPUT DATA* <sup>1</sup> (R7D to Master)	INPUT DATA* <sup>2</sup> (Master to R7D)
R7D-EAx	1	0
R7D-ECx	0	1

### ■ STATUS

Status signal can be included in the transmission data when the setting is enabled using the PC Configurator software (model: R7CON). For details, refer to "STATUS in I/O DATA DESCRIPTIONS".

STATUS	OUTPUT DATA* <sup>1</sup> (R7D to Master)	INPUT DATA* <sup>2</sup> (Master to R7D)
Enabled	1	0
Disabled	0	0

\*1. Output Data means those sent to the master.

\*2. Input Data means those received from the master.

## EXTERNAL DIMENSIONS & TERMINAL ASSIGNMENTS unit: mm [inch]

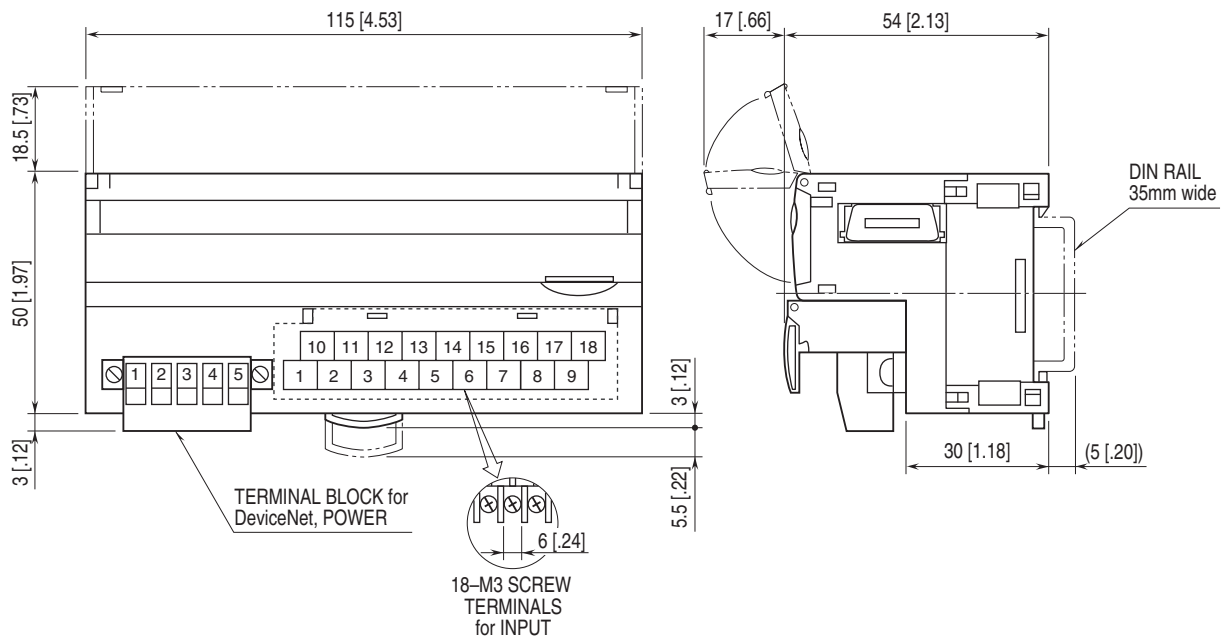

**SCHEMATIC CIRCUITRY & CONNECTION DIAGRAM**

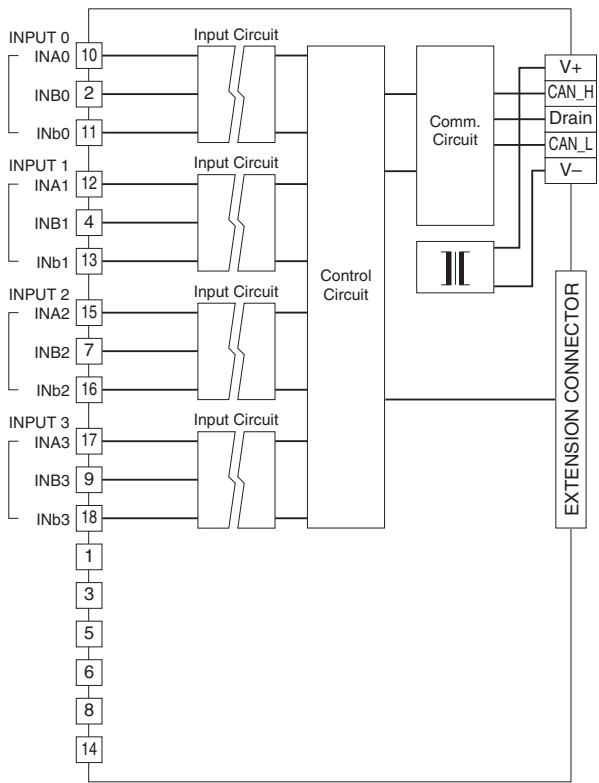

■ Input Connection Example

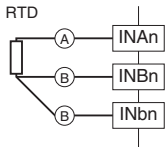

Specifications are subject to change without notice.