

Remote I/O R7 Series

DeviceNet® I/O MODULE

(DC voltage/current input, 4 points, isolated)

Functions & Features

- 4 points DC voltage/current input module for DeviceNet
- Extension module can be connected
- Input range can be selected with the front DIP switches for all channels
- Individual channels, zero adjustment, span adjustment, and scaling can be set with the configurator software (model: R7CON)

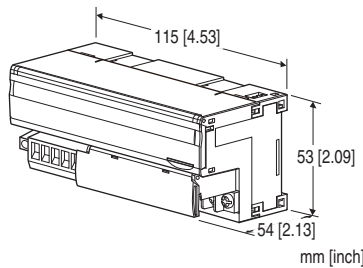

MODEL:R7D-SV4[1]

ORDERING INFORMATION

- Code number: R7D-SV4[1]
- Specify a code from below for [1].
(e.g. R7D-SV4/Q)
- Specify the specification for option code /Q
(e.g. /C01/SET)

I/O TYPE

SV4: DC voltage/current input (10 V/20 mA), 4 points

[1] OPTIONS

Standards & Approvals

blank: CE marking

/UL: UL approval, CE marking

Other Options

blank: none

/Q: Option other than the above (specify the specification)
(UL not available)

SPECIFICATIONS OF OPTION: Q (multiple selections)

COATING (For the detail, refer to our web site.)

/C01: Silicone coating

/C02: Polyurethane coating

/C03: Rubber coating

EX-FACTORY SETTING

/SET: Preset according to the Ordering Information Sheet
(No. ESU-7802-A)

RELATED PRODUCTS

- PC Configurator cable (model: MCN-CON or COP-US)
- PC configurator software (model: R7CON)
- EDS file

The EDS files and configurator software are downloadable at our web site.

(Extension modules are registered in the EDS file as a combination of a basic module)

- Discrete input extension module (model: R7D-EAx)
- Discrete output extension module (model: R7D-ECx)

GENERAL SPECIFICATIONS

Connection

DeviceNet: Euro type connector terminal

(applicable wire size: 0.2 to 2.5 mm², stripped length 7 mm)

Input: M3 separable screw terminal (torque 0.5 N·m)

Solderless terminal: Refer to the drawing at the end of the section.

Recommended manufacturer: Japan Solderless Terminal MFG. Co., Ltd., Nichifu Co., Ltd.

Applicable wire size: 0.25 to 1.65 mm² (AWG 22 to 16)

Screw terminal: Nickel-plated steel

Housing material: Flame-resistant resin (gray)

Isolation: Input 0 to input 1 to input 2 to input 3 to DeviceNet

Zero adjustments: Configurable via R7CON

Span adjustments: Configurable via R7CON

Input range: Selectable with the DIP SW on the front of the unit or configurable via R7CON

Extension: No extension (*), Discrete input 8 or 16 points, Discrete output 8 or 16 points

Selectable with the front DIP SW

(*) Factory default setting

Conversion rate: Selectable with the front DIP SW

Configurator connection: 2.5 dia. miniature jack

■Recommended solderless terminal

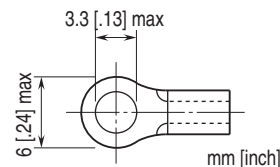

DeviceNet COMMUNICATION

Network cable: Approved for DeviceNet

Baud rate setting: 125 kbps (default), 250 kbps, 500 kbps, auto-tracking (rotary switch)

(Refer to the instruction manual.)

Status indicator LEDs: MS, NS

(Refer to the instruction manual for details.)

Node address setting: 1 - 63 (rotary switch, default:00)

(Refer to the instruction manual.)

Communication: Supports poll and cyclic

(Bit-strobe and COS (change of state) are not supported)

INPUT SPECIFICATIONS

■ DC Current

Input resistance: 70 Ω

Input range: -20 to +20 mA DC, 0 to 20 mA DC,
4 to 20 mA DC

■ Narrow span voltage

Input resistance: ≥ 100 k Ω

Input range: -1 to +1 V DC, 0 to 1 V DC, -0.5 to +0.5 V DC

■ Wide span voltage

Input resistance: ≥ 1 M Ω

Input range: -10 to +10 V DC (*), -5 to +5 V DC,
0 to 10 V DC, 0 to 5 V DC, 1 to 5 V DC

(*) Factory default setting

INSTALLATION

Supply voltage to network: 11 - 25 V DC supplied through
the network terminal block

Current Consumption:

Approx. 60 mA @ 24 V DC

Approx. 110 mA @ 11 V DC

Operating temperature: -10 to +55°C (14 to 131°F)

Storage temperature: -20 to +65°C (-4 to +149°F)

Operating humidity: 30 to 90 %RH (non-condensing)

Atmosphere: No corrosive gas or heavy dust

Mounting: DIN rail (35 mm rail)

Weight: 200 g (0.44 lb)

PERFORMANCE

Conversion rate / conversion accuracy:

10 msec./ ± 0.8 %, 20 msec./ ± 0.4 %, 40 msec./ ± 0.2 %, 80
msec./ ± 0.1 % (*)

(*) Factory setting

Data range: 0 - 10000 of the input range

(Scaling of converted data is configurable with the
configurator software (model: R7CON))

Temp. coefficient: ± 0.015 %/°C (± 0.008 %/°F)

Response time: Conversion rate $\times 2 + 50$ msec. (0 - 90 %)

Insulation resistance: ≥ 100 M Ω with 500 V DC

Dielectric strength: 1500 V AC @ 1 minute (input 0 to input
1 to input 2 to input 3 to DeviceNet)

STANDARDS & APPROVALS

EU conformity:

EMC Directive

EMI EN 61000-6-4

EMS EN 61000-6-2

RoHS Directive

Approval:

UL/C-UL nonincendive Class I, Division 2,

Groups A, B, C, and D

(ANSI/UL 121201, CAN/CSA-C22.2 No.213-17)

UL/C-UL general safety requirements

(UL 61010-1, CAN/CSA-C22.2 No.61010-1)

Note: This equipment is to be supplied by a Class 2 power
supply when using as conformity with UL/C-UL.

EXTERNAL VIEW

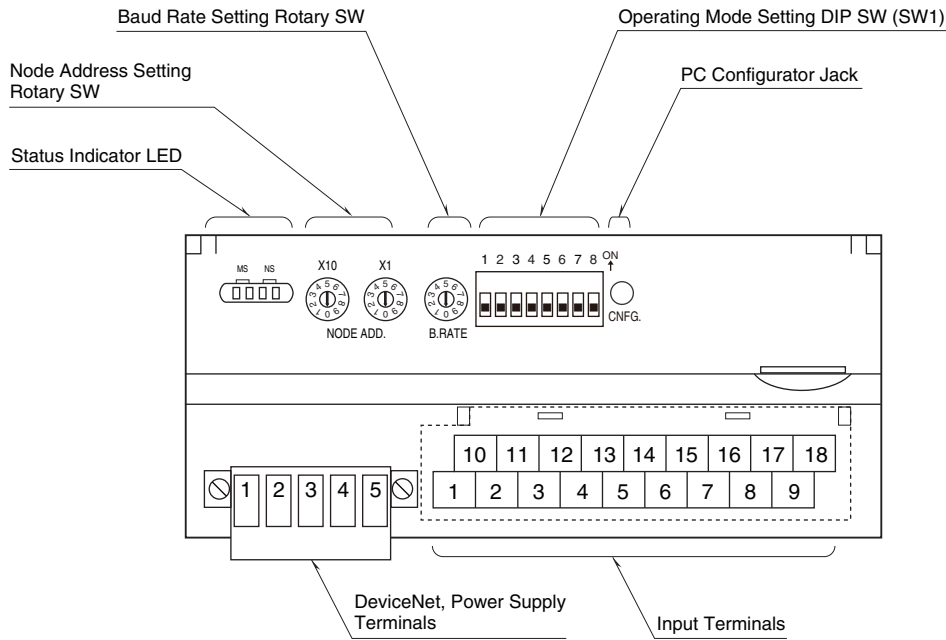

TERMINAL ASSIGNMENTS

■ INPUT TERMINAL ASSIGNMENT

10	11	12	13	14	15	16	17	18
VL0	I0	VL1	I1	NC	VL2	I2	VL3	I3
1	2	3	4	5	6	7	8	9
VH0	COM0	VH1	COM1	NC	VH2	COM2	VH3	COM3

NO.	ID	FUNCTION	NO.	ID	FUNCTION
1	VH0	Wide span volt. 0	10	VL0	Narrow span volt. 0
2	COM0	Common 0	11	I0	Current range 0
3	VH1	Wide span volt. 1	12	VL1	Narrow span volt. 1
4	COM1	Common 1	13	I1	Current range 1
5	NC	No connection	14	NC	No connection
6	VH2	Wide span volt. 2	15	VL2	Narrow span volt. 2
7	COM2	Common 2	16	I2	Current range 2
8	VH3	Wide span volt. 3	17	VL3	Narrow span volt. 3
9	COM3	Common 3	18	I3	Current range 3

■ DeviceNet TERMINAL ASSIGNMENT

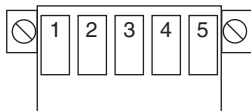

PIN NO.	COLOR	ID	FUNCTION
1	Red	V+	Network power supply +
2	White	CAN_H	Network data High
3	—	Drain	Shield
4	Blue	CAN_L	Network data Low
5	Black	V-	Network power supply -

DATA CONVERSION

■ INPUT RANGE AND DATA CONVERSION (FACTORY DEFAULT SETTING)

Analog input data is converted into digital representations of 0 – 100% proportional to each scaled range.

The converted % values are multiplied by 100 and expressed in 16 bits.

Overrange input is possible from -15 to +115% of the nominal range.

When the signal exceeds the limit, the data is fixed at -15% or +115%.

• Input Range 0 – 5V DC

Input Value	Input %	Converted Data, Decimal	Converted Data, Hex
$\leq -0.75V$	-15%	-1500	FA24
0V	0%	0	0
5V	100%	10000	2710
$\geq 5.75V$	115%	11500	2CEC

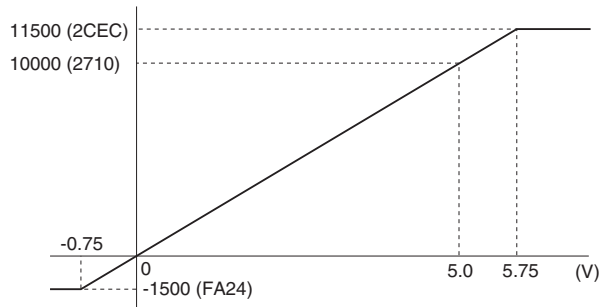

DATA ALLOCATION

• **Example 1. Analog Input Module, without Status**

Output Data		Input Data
Begin +0	Analog Input Module CH0	None
+1	CH1	
+2	CH2	
+3	CH3	

• **Example 2. Analog Input Module, with Status**

Output Data		Input Data
Begin +0	Analog Input Module CH0	None
+1	CH1	
+2	CH2	
+3	CH3	
+4	Status	

• **Example 3. Analog Input Module + R7D-EA16, with Status**

Output Data		Input Data
Begin +0	Analog Input Module CH0	None
+1	CH1	
+2	CH2	
+3	CH3	
+4	R7D-EA16	
+5	Status	

• **Example 4. Analog Input Module + R7D-EC16x, with Status**

Output Data		Input Data
Begin +0	Analog Input Module CH0	R7D-EC16x
+1	CH1	
+2	CH2	
+3	CH3	
+4	Status	

I/O DATA DESCRIPTIONS

■ ANALOG INPUT



16-bit binary data
Negative values represented in 2's complements

■ DISCRETE I/O

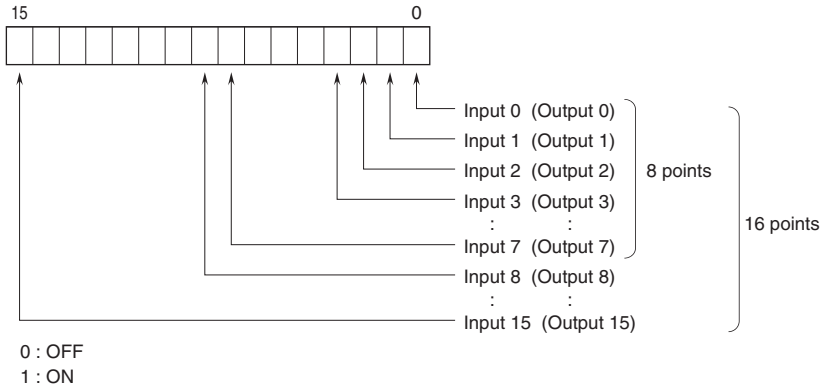

■ STATUS

Bit 0 to 7: Analog input modules can show input status of each channel.
Bit 8 to 10: Shows the power supply status.

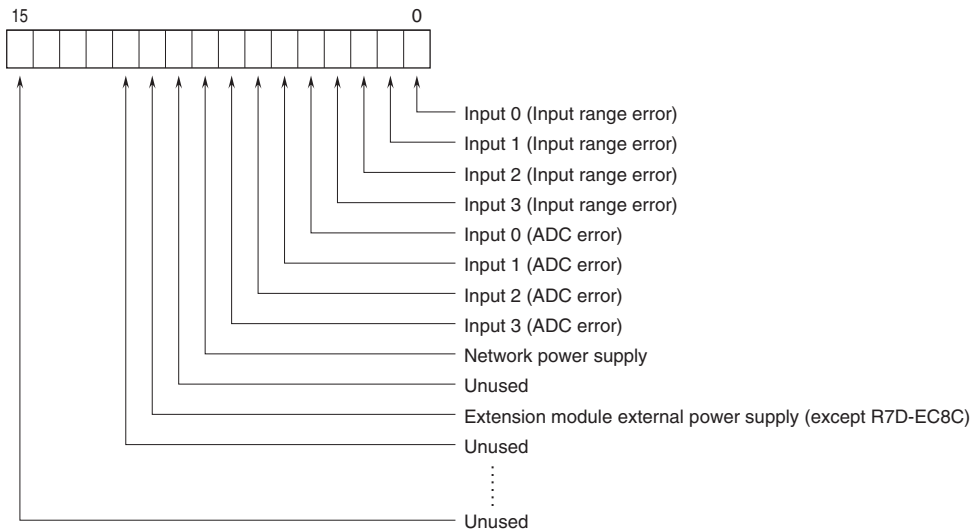

Input range error ($\leq -15\%$, $\geq +115\%$)
0 : Normal 1 : Error
ADC error (no response from ADC)
0 : Normal 1 : Error
Power supply
0 : Normal 1 : Error

TRANSMISSION DATA DESCRIPTIONS

■ BASIC MODULE

Transmitted data (word) depends upon the modules types.

MODEL	OUTPUT DATA* ¹ (R7D to Master)	INPUT DATA* ² (Master to R7D)
R7D-SV4	4	0

■ EXTENSION MODULE

Transmitted data (word) for the extension module is added.

MODEL	OUTPUT DATA* ¹ (R7D to Master)	INPUT DATA* ² (Master to R7D)
R7D-EAx	1	0
R7D-ECx	0	1

■ STATUS

Status signal can be included in the transmission data when the setting is enabled using the PC Configurator software (model: R7CON). For details, refer to "STATUS in I/O DATA DESCRIPTIONS".

STATUS	OUTPUT DATA* ¹ (R7D to Master)	INPUT DATA* ² (Master to R7D)
Enabled	1	0
Disabled	0	0

*1. Output Data means those sent to the master.

*2. Input Data means those received from the master.

EXTERNAL DIMENSIONS & TERMINAL ASSIGNMENTS unit: mm [inch]

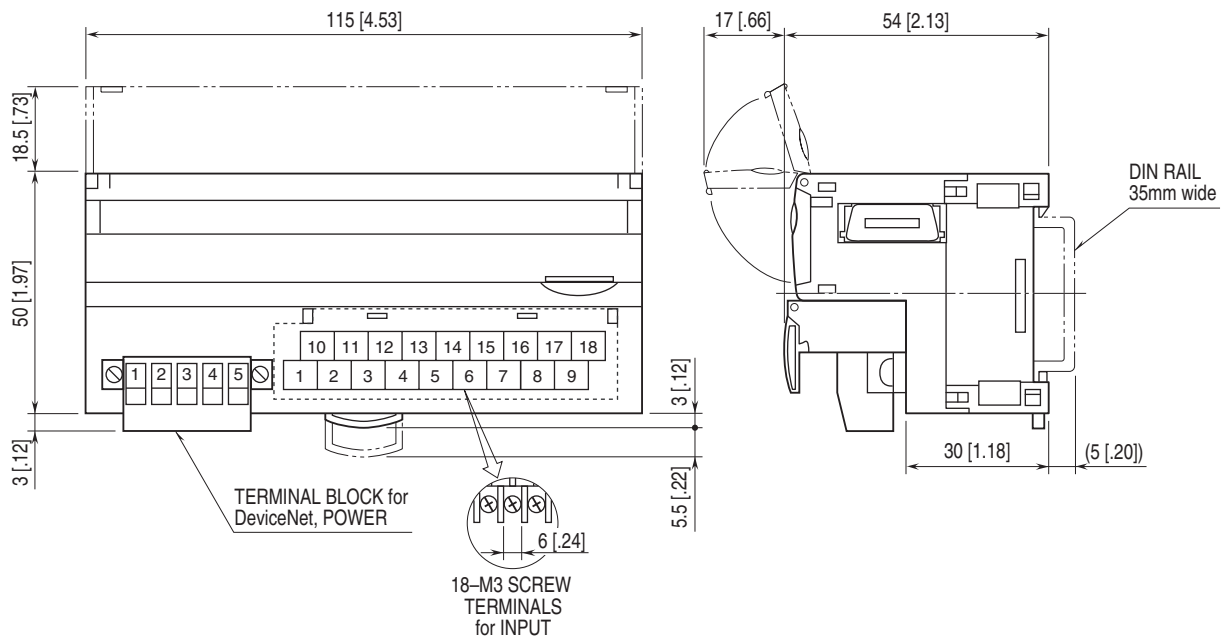

SCHEMATIC CIRCUITRY & CONNECTION DIAGRAM

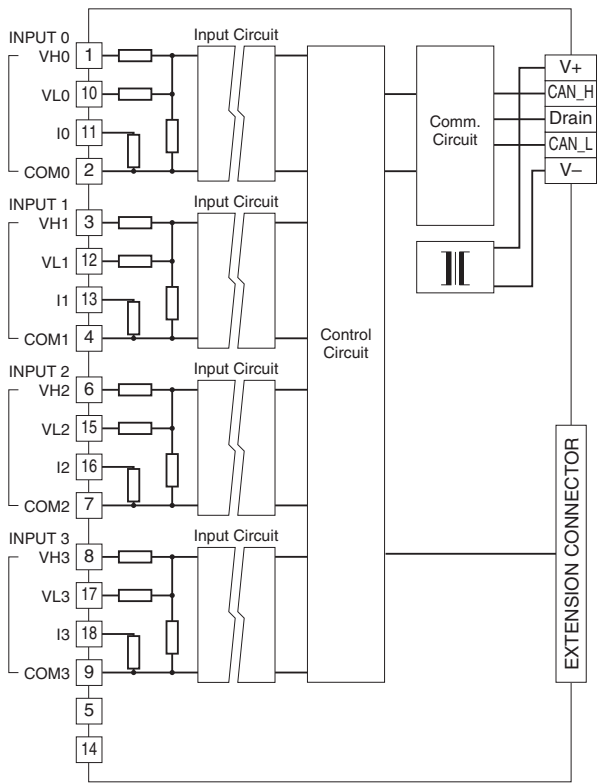

■ Input Connection Examples

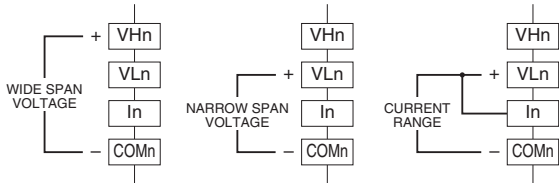

Be sure to close across VLn and In terminals for a current input.



Specifications are subject to change without notice.