

Remote I/O R7 Series

ETHERNET I/O MODULE

(potentiometer input, 4 points, isolated, Modbus/TCP use)

Functions & Features

- 4 points potentiometer input module for Modbus/TCP (Ethernet)
- Extension module can be connected
- Individual channels, zero adjustment, span adjustment, and scaling can be set with the configurator software (model: R7CON)

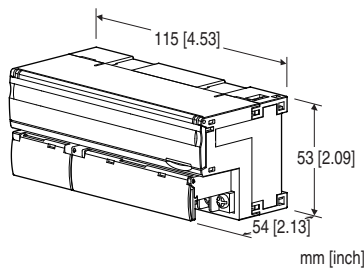

MODEL:R7E-MS4-R[1]

ORDERING INFORMATION

- Code number: R7E-MS4-R[1]
Specify a code from below for [1].
(e.g. R7E-MS4-R/Q)
- Specify the specification for option code /Q
(e.g. /C01/SET)

I/O TYPE

MS4: Potentiometer input, 4 points

POWER INPUT

DC Power

R: 24 V DC

(Operational voltage range 24 V \pm 10 %, ripple 10 %p-p max.)

[1] OPTIONS

blank: none

/Q: With options (specify the specification)

SPECIFICATIONS OF OPTION: Q (multiple selections)

COATING (For the detail, refer to our web site.)

/C01: Silicone coating

/C02: Polyurethane coating

/C03: Rubber coating

EX-FACTORY SETTING

/SET: Preset according to the Ordering Information Sheet
(No. ESU-7807-Q)

RELATED PRODUCTS

- PC Configurator cable (model: MCN-CON or COP-US)
- PC configurator software (model: R7CON)
Downloadable at our web site.
- Discrete input extension module (model: R7E-EAx)
- Discrete output extension module (model: R7E-ECx)

Note: PC Configurator Software is required to set IP address.

GENERAL SPECIFICATIONS

Connection

Ethernet: RJ-45 connector

Power, input: M3 separable screw terminal
(torque 0.5 N·m)

Solderless terminal: Refer to the drawing at the end of the section.

Recommended manufacturer: Japan Solderless Terminal MFG. Co., Ltd., Nichifu Co., Ltd.

Applicable wire size: 0.25 to 1.65 mm² (AWG 22 to 16)

Screw terminal: Nickel-plated steel

Housing material: Flame-resistant resin (gray)

Isolation: Input 0 to input 1 to input 2 to input 3 to Ethernet to power to FG

Zero adjustments: Configurable via R7CON

Span adjustments: Configurable via R7CON

Extension: No extension (*), Discrete input 8 or 16 points, Discrete output 8 or 16 points
Selectable with the front DIP SW

(*): Factory default setting

Conversion rate: Selectable with the front DIP SW

Status indicator LEDs: PWR, RUN

Configurator connection: 2.5 dia. miniature jack

■Recommended solderless terminal

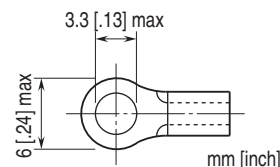

ETHERNET COMMUNICATION

Physical layer standard: IEEE 802.3u
Data link layer: 10BASE-T / 100BASE-TX
Baud rate: 10 / 100 Mbps, Auto Negotiation
Protocol: Modbus/TCP
Data: RTU (binary)
Max. number of socket connections: Two (2)
Transmission media: 10BASE-T (STP cable, category 5)
 100BASE-TX (STP cable, category 5e)
Max. segment length: 100 meters
IP address: Can be set and changed with PC Configurator
 Software (model: R7CON) (default: 192.168.0.1)
Subnet Mask: Can be set and changed with PC Configurator
 Software (model: R7CON) (default: 255.255.255.0)
Default Gateway: Can be set and changed with PC
 Configurator Software (model: R7CON) (Ver.2.41 or later)
 (default: 192.168.0.100)
Port No.: 502
 DHCP available (Ver.3.00 or later)
Ethernet indicator LEDs: LINK, LINK100, COL

STANDARDS & APPROVALS

EU conformity:
 EMC Directive
 EMI EN 61000-6-4
 EMS EN 61000-6-2
 RoHS Directive

INPUT SPECIFICATIONS

Potentiometer: Total resistance 100 Ω - 20 k Ω
Minimum span: 50 % of total resistance
Excitation: Approx. 0.2 V DC

INSTALLATION

Current consumption
 •DC: Approx. 97 mA
Operating temperature: -10 to +55°C (14 to 131°F)
Storage temperature: -20 to +65°C (-4 to +149°F)
Operating humidity: 30 to 90 %RH (non-condensing)
Atmosphere: No corrosive gas or heavy dust
Mounting: DIN rail (35 mm rail)
Weight: 200 g (0.44 lb)

PERFORMANCE

Conversion rate / conversion accuracy:
 10 msec./ ± 0.8 %, 20 msec./ ± 0.4 %, 40 msec./ ± 0.2 %, 80
 msec./ ± 0.1 % (*)
 (*) Factory setting
Data range: 0 - 10000 of the input range
 (Scaling of converted data is configurable with the
 configurator software (model: R7CON))
Temp. coefficient: ± 0.015 %/ $^{\circ}$ C (± 0.008 %/ $^{\circ}$ F)
Response time: Conversion rate $\times 2 + 50$ msec. (0 - 90 %)
Insulation resistance: ≥ 100 M Ω with 500 V DC
Dielectric strength: 1500 V AC @ 1 minute (input 0 to input
 1 to input 2 to input 3 to Ethernet to power to FG)

EXTERNAL VIEW

■ SIDE VIEW

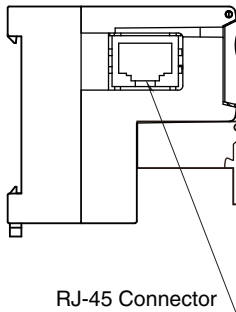

RJ-45 Connector

■ FRONT VIEW

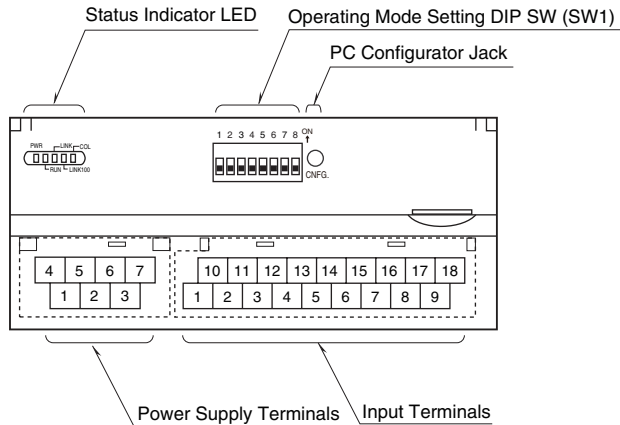

Power Supply Terminals Input Terminals

TERMINAL ASSIGNMENTS

■ INPUT TERMINAL ASSIGNMENT

10	11	12	13	14	15	16	17	18
H0	S0	H1	S1	NC	H2	S2	H3	S3
1	2	3	4	5	6	7	8	9
NC	L0	NC	L1	NC	NC	L2	NC	L3

NO.	ID	FUNCTION	NO.	ID	FUNCTION
1	NC	No connection	10	H0	Pot H0
2	L0	Pot L0	11	S0	Pot S0
3	NC	No connection	12	H1	Pot H1
4	L1	Pot L1	13	S1	Pot S1
5	NC	No connection	14	NC	No connection
6	NC	No connection	15	H2	Pot H2
7	L2	Pot L2	16	S2	Pot S2
8	NC	No connection	17	H3	Pot H3
9	L3	Pot L3	18	S3	Pot S3

■ POWER SUPPLY TERMINAL ASSIGNMENT

4	5	6	7
NC	NC	+24V	0V
1	2	3	
NC	NC	FG	

NO.	ID	FUNCTION, NOTES
1	NC	----
2	NC	----
3	FG	FG
4	NC	----
5	NC	----
6	+24V	Power input (24V DC)
7	0V	Power input (0V)

MODBUS FUNCTION CODES & SUPPORTED CODES
--

■ Data and Control Functions

CODE	NAME	
01	Read Coil Status	Digital output from the slave
02	Read Input Status	Status of digital inputs to the slave
03	Read Holding Registers	General purpose register within the slave
04	Read Input Registers	Collected data from the field by the slave
05	Force Single Coil	Digital output from the slave
06	Preset Single Register	General purpose register within the slave
08	Diagnostics	
11	Fetch Comm. Event Counter	Fetch a status word and an event counter
12	Fetch Comm. Event Log	A status word, an event counter, a message count and a field of event bytes
15	Force Multiple Coils	Digital output from the slave
16	Preset Multiple Registers	General purpose register within the slave
17	Report Slave ID	Slave type/ 'RUN' status

■ Exception Codes

CODE	NAME	
01	Illegal Function	Function code is not allowable for the slave
02	Illegal Data Address	Address is not available within the slave
03	Illegal Data Value	Data is not valid for the function

■ Diagnostic Subfunctions

CODE	NAME	
00	Return Query Data	Loop back test

MODBUS I/O ASSIGNMENT

	ADDRESS	DATA TYPE	DATA
Coil (0X)	1 – 16		Digital Output (discrete output of the basic module) (unused)
	17 – 32		Digital Output (discrete output of the extension module)
Inputs (1X)	1 – 16		Digital Input (discrete input of the basic module) (unused)
	17 – 32		Digital Input (discrete input of the extension module)
	33 – 48		Reserved (unused)
	49 – 64		Module Status
	65 – 80		Reserved (unused)
Input Registers (3X)	1 – 4	I	Analog Input
	5 – 16	----	Reserved (unused)
	17 – 24	F	Analog Input
	25 – 48	----	Reserved (unused)
Holding Registers (4X)	1 – 48	----	Analog Output (unused)

I : Integer, -1500 – +11500 (-15 – +115%)

F : Floating

Note: DO NOT access addresses other than mentioned above. Such access may cause problems such as inadequate operation.

■ STATUS

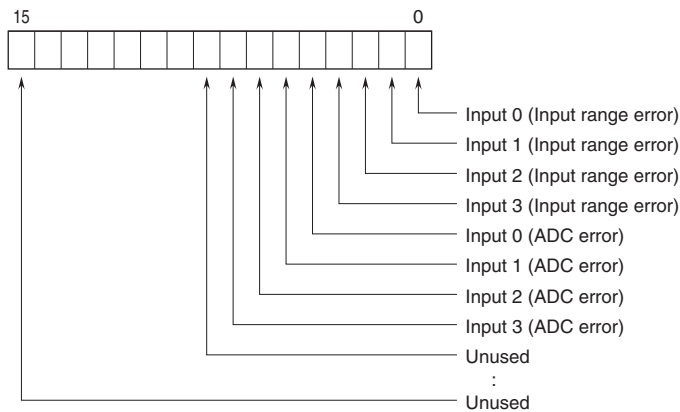

Input range error ($\leq -15\%$, $\geq +115\%$)

0 : Normal 1 : Error

ADC error (no response from ADC)

0 : Normal 1 : Error

EXTERNAL DIMENSIONS & TERMINAL ASSIGNMENTS unit: mm [inch]

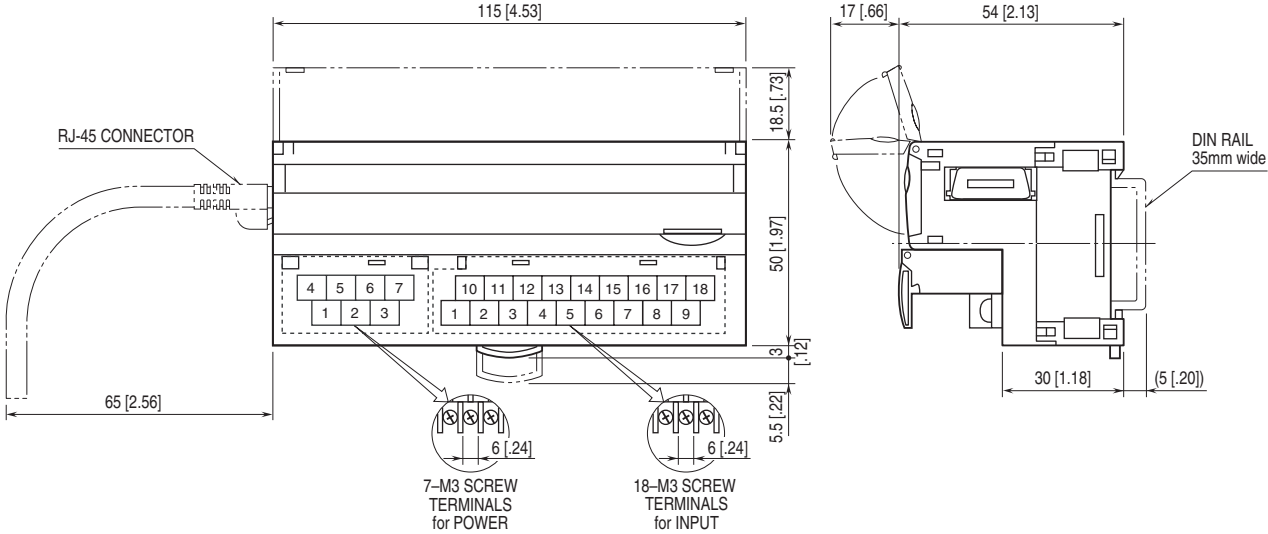

SCHEMATIC CIRCUITRY & CONNECTION DIAGRAM

Note: In order to improve EMC performance, bond the FG terminal to ground.

Caution: FG terminal is NOT a protective conductor terminal.

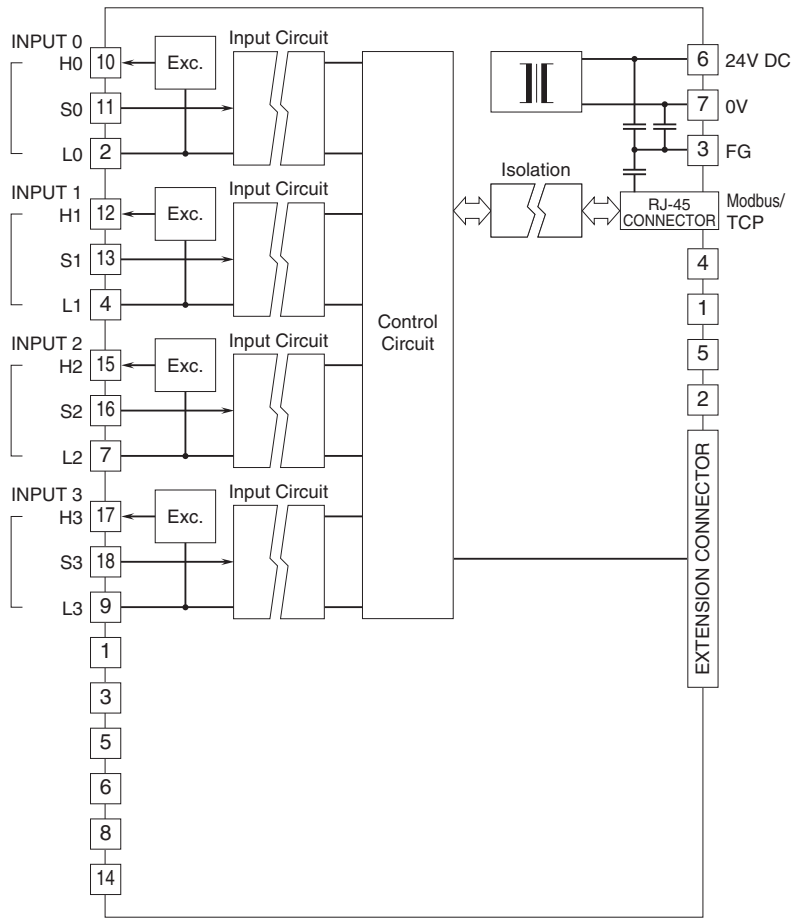

■ Input Connection Example

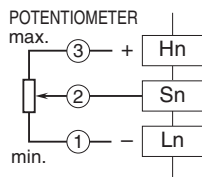

Specifications are subject to change without notice.