

Remote I/O R7 Series

ETHERNET I/O MODULE

(totalized pulse input, 8 points, Modbus/TCP use)

Functions & Features

- 8 points totalized pulse input module for Modbus/TCP (Ethernet)
- Extension module can be connected

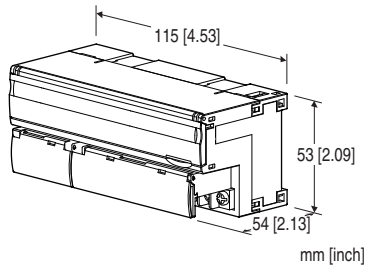

MODEL:R7E-PA8-R[1]

ORDERING INFORMATION

- Code number: R7E-PA8-R[1]
- Specify a code from below for [1].
(e.g. R7E-PA8-R/Q)
- Specify the specification for option code /Q
(e.g. /C01/SET)

I/O TYPE

PA8: Totalized pulse input, 8 points

POWER INPUT

DC Power

R: 24 V DC

(Operational voltage range 24 V \pm 10 %, ripple 10 %p-p max.)

[1] OPTIONS

blank: none

/Q: With options (specify the specification)

SPECIFICATIONS OF OPTION: Q (multiple selections)

COATING (For the detail, refer to our web site.)

/C01: Silicone coating

/C02: Polyurethane coating

/C03: Rubber coating

EX-FACTORY SETTING

/SET: Preset according to the Ordering Information Sheet

(No. ESU-7807-AJ)

RELATED PRODUCTS

- PC Configurator cable (model: MCN-CON or COP-US)
 - PC configurator software (model: R7CON)
- Downloadable at our web site.
- Discrete input extension module (model: R7E-EAx)
 - Discrete output extension module (model: R7E-ECx)

Note: PC Configurator Software is required to set IP address.

GENERAL SPECIFICATIONS

Connection

Ethernet: RJ-45 connector

Power, input: M3 separable screw terminal
(torque 0.5 N·m)

Solderless terminal: Refer to the drawing at the end of the section.

Recommended manufacturer: Japan Solderless Terminal MFG. Co., Ltd., Nichifu Co., Ltd.

Applicable wire size: 0.25 to 1.65 mm² (AWG 22 to 16)

Screw terminal: Nickel-plated steel

Housing material: Flame-resistant resin (gray)

Isolation: Input to Ethernet to power to FG

Extension: No extension (*), Discrete input 8 or 16 points, Discrete output 8 or 16 points

Selectable with the front DIP SW

(* Factory default setting)

Status indicator LEDs: PWR, RUN

Totalized pulse input status indicator LED: LED turns ON with contact ON

Configurator connection: 2.5 dia. miniature jack

■Recommended solderless terminal

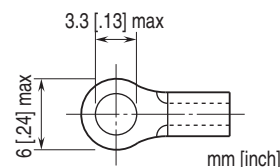

ETHERNET COMMUNICATION

Physical layer standard: IEEE 802.3u

Data link layer: 10BASE-T / 100BASE-TX

Baud rate: 10 / 100 Mbps, Auto Negotiation

Protocol: Modbus/TCP

Data: RTU (binary)

Max. number of socket connections: Two (2)

Transmission media: 10BASE-T (STP cable, category 5)

100BASE-TX (STP cable, category 5e)

Max. segment length: 100 meters

IP address: Can be set and changed with PC Configurator Software (model: R7CON) (default: 192.168.0.1)

Subnet Mask: Can be set and changed with PC Configurator Software (model: R7CON) (default: 255.255.255.0)

Default Gateway: Can be set and changed with PC Configurator Software (model: R7CON) (Ver.2.41 or later) (default: 192.168.0.100)

Port No.: 502

DHCP available (Ver.3.00 or later)

Ethernet indicator LEDs: LINK, LINK100, COL

INPUT SPECIFICATIONS

Common: Positive or negative common (NPN/PNP) per 8 points

• **Excitation (PNP, NPN input)**

Sensing voltage: 24 V DC $\pm 10\%$; ripple 5 %p-p max

• **NPN input**

ON voltage / ON current: ≥ 16 V DC ($V+ - P_{Ix}$) / ≥ 3.7 mA

OFF voltage / OFF current: ≤ 5 V DC ($V+ - P_{Ix}$) / ≤ 1 mA

• **PNP input**

ON voltage / ON current: ≥ 16 V DC ($V+ - C_x$) / ≥ 3.7 mA

OFF voltage / OFF current: ≤ 5 V DC ($V+ - C_x$) / ≤ 1 mA

• **Voltage pulse input**

ON voltage / ON current: ≥ 16 V DC ($P_{Ix} - C_x$) / ≥ 3.7 mA

OFF voltage / OFF current: ≤ 5 V DC ($P_{Ix} - C_x$) / ≤ 1 mA

Input current: ≤ 5.5 mA per point at 24 V DC

Input resistance: Approx. 4.4 k Ω

ON delay: ≤ 2.0 msec.

OFF delay: ≤ 2.0 msec.

Max. Frequency: 100 Hz (This unit is designed to be able to accept a frequency up to 100 Hz, however, 'chattering' contact must be avoided for accurate measuring of such high frequency. Use relays that do not cause any chattering)

Minimum ON/OFF pulse requirements: 5 msec.

Totalized pulse count: 0 - 4 294 967 295

Max. totalized pulse count: 1 000 - 4 294 967 295

(Factory default: 9 999 999)

Overflow reset value: 0 or 1 (Factory default: 0)

INSTALLATION

Current consumption

• DC: Approx. 80 mA

Operating temperature: -10 to +55°C (14 to 131°F)

Storage temperature: -20 to +65°C (-4 to +149°F)

Operating humidity: 30 to 90 %RH (non-condensing)

Atmosphere: No corrosive gas or heavy dust

Mounting: DIN rail (35 mm rail)

Weight: 200 g (0.44 lb)

PERFORMANCE

Insulation resistance: ≥ 100 M Ω with 500 V DC

Dielectric strength: 1500 V AC @ 1 minute (input to Ethernet to power to FG)

EXTERNAL VIEW

■ SIDE VIEW

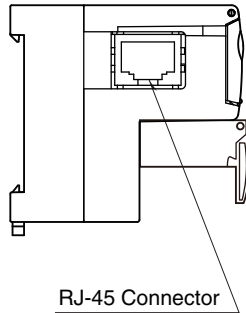

■ FRONT VIEW

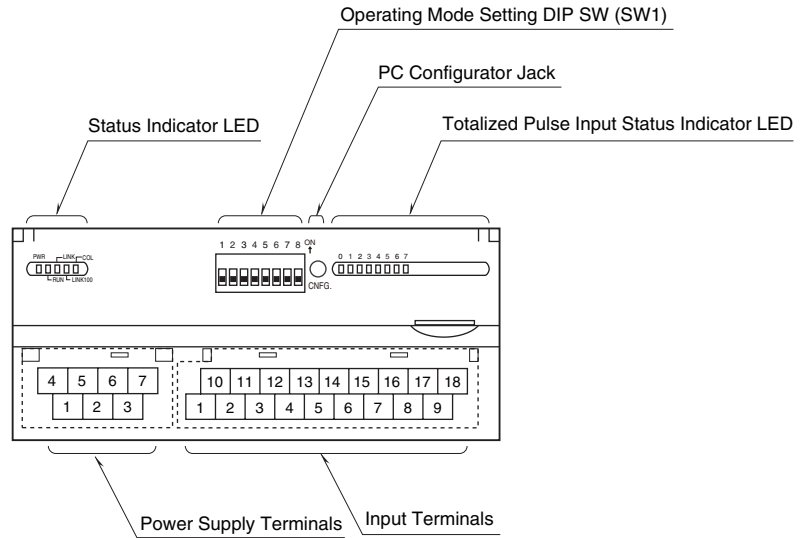

TERMINAL ASSIGNMENTS

■ INPUT TERMINAL ASSIGNMENT

10 V+	11 PI0	12 PI1	13 PI2	14 PI3	15 PI4	16 PI5	17 PI6	18 PI7
1 V-	2 C0	3 C1	4 C2	5 C3	6 C4	7 C5	8 C6	9 C7

NO.	ID	FUNCTION	NO.	ID	FUNCTION
1	V-	Excitation (-)	10	V+	Excitation (+)
2	C0	Common	11	PI0	Input 0
3	C1	Common	12	PI1	Input 1
4	C2	Common	13	PI2	Input 2
5	C3	Common	14	PI3	Input 3
6	C4	Common	15	PI4	Input 4
7	C5	Common	16	PI5	Input 5
8	C6	Common	17	PI6	Input 6
9	C7	Common	18	PI7	Input 7

■ POWER SUPPLY TERMINAL ASSIGNMENT

4 NC	5 NC	6 +24V	7 0V
1 NC	2 NC	3 FG	

NO.	ID	FUNCTION, NOTES
1	NC	----
2	NC	----
3	FG	FG
4	NC	----
5	NC	----
6	+24V	Power input (24V DC)
7	0V	Power input (0V)

MODBUS FUNCTION CODES & SUPPORTED CODES
--

■ Data and Control Functions

CODE	NAME	
01	Read Coil Status	Digital output from the slave
02	Read Input Status	Status of digital inputs to the slave
03	Read Holding Registers	General purpose register within the slave
04	Read Input Registers	Collected data from the field by the slave
05	Force Single Coil	Digital output from the slave
06	Preset Single Register	General purpose register within the slave
08	Diagnostics	
11	Fetch Comm. Event Counter	Fetch a status word and an event counter
12	Fetch Comm. Event Log	A status word, an event counter, a message count and a field of event bytes
15	Force Multiple Coils	Digital output from the slave
16	Preset Multiple Registers	General purpose register within the slave
17	Report Slave ID	Slave type/ 'RUN' status

■ Exception Codes

CODE	NAME	
01	Illegal Function	Function code is not allowable for the slave
02	Illegal Data Address	Address is not available within the slave
03	Illegal Data Value	Data is not valid for the function

■ Diagnostic Subfunctions

CODE	NAME	
00	Return Query Data	Loop back test

MODBUS I/O ASSIGNMENT

Master→Slave (R7E-PA8)

Coil Status (0X)	1 – 16	Unused
	17 – 32	Extension output module data
Holding Registers (4X)	1	CH 0 Preset value (upper)
	2	CH 0 Preset value (lower)
	3	CH 1 Preset value (upper)
	4	CH 1 Preset value (lower)
	5	CH 2 Preset value (upper)
	6	CH 2 Preset value (lower)
	7	CH 3 Preset value (upper)
	8	CH 3 Preset value (lower)
	9	CH 4 Preset value (upper)
	10	CH 4 Preset value (lower)
	11	CH 5 Preset value (upper)
	12	CH 5 Preset value (lower)
	13	CH 6 Preset value (upper)
	14	CH 6 Preset value (lower)
	15	CH 7 Preset value (upper)
	16	CH 7 Preset value (lower)
	17	CH 0 Return value write data (upper)
	18	CH 0 Return value write data (lower)
	19	CH 1 Return value write data (upper)
	20	CH 1 Return value write data (lower)
	21	CH 2 Return value write data (upper)
	22	CH 2 Return value write data (lower)
	23	CH 3 Return value write data (upper)
	24	CH 3 Return value write data (lower)
	25	CH 4 Return value write data (upper)
	26	CH 4 Return value write data (lower)
	27	CH 5 Return value write data (upper)
	28	CH 5 Return value write data (lower)
	29	CH 6 Return value write data (upper)
	30	CH 6 Return value write data (lower)
	31	CH 7 Return value write data (upper)
	32	CH 7 Return value write data (lower)
	33	CH 0 Max. value write data (upper)
	34	CH 0 Max. value write data (lower)
	35	CH 1 Max. value write data (upper)
	36	CH 1 Max. value write data (lower)
	37	CH 2 Max. value write data (upper)
	38	CH 2 Max. value write data (lower)
	39	CH 3 Max. value write data (upper)
	40	CH 3 Max. value write data (lower)
	41	CH 4 Max. value write data (upper)
	42	CH 4 Max. value write data (lower)
	43	CH 5 Max. value write data (upper)
	44	CH 5 Max. value write data (lower)
	45	CH 6 Max. value write data (upper)
	46	CH 6 Max. value write data (lower)
	47	CH 7 Max. value write data (upper)
	48	CH 7 Max. value write data (lower)

Slave (R7E-PA8)→Master

Input Status (1X)	1 – 16	Unused
	17 – 32	Extension input module data
	33 – 48	Reserved (unused)
	49 – 64	Status (unused)
Input Registers (3X)	1	CH 0 Parameter data (upper)
	2	CH 0 Parameter data (lower)
	3	CH 1 Parameter data (upper)
	4	CH 1 Parameter data (lower)
	5	CH 2 Parameter data (upper)
	6	CH 2 Parameter data (lower)
	7	CH 3 Parameter data (upper)
	8	CH 3 Parameter data (lower)
	9	CH 4 Parameter data (upper)
	10	CH 4 Parameter data (lower)
	11	CH 5 Parameter data (upper)
	12	CH 5 Parameter data (lower)
	13	CH 6 Parameter data (upper)
	14	CH 6 Parameter data (lower)
	15	CH 7 Parameter data (upper)
	16	CH 7 Parameter data (lower)
	17	CH 0 Return value read data (upper)
	18	CH 0 Return value read data (lower)
	19	CH 1 Return value read data (upper)
	20	CH 1 Return value read data (lower)
	21	CH 2 Return value read data (upper)
	22	CH 2 Return value read data (lower)
	23	CH 3 Return value read data (upper)
	24	CH 3 Return value read data (lower)
	25	CH 4 Return value read data (upper)
	26	CH 4 Return value read data (lower)
	27	CH 5 Return value read data (upper)
	28	CH 5 Return value read data (lower)
	29	CH 6 Return value read data (upper)
	30	CH 6 Return value read data (lower)
	31	CH 7 Return value read data (upper)
	32	CH 7 Return value read data (lower)
	33	CH 0 Max. value read data (upper)
	34	CH 0 Max. value read data (lower)
	35	CH 1 Max. value read data (upper)
	36	CH 1 Max. value read data (lower)
	37	CH 2 Max. value read data (upper)
	38	CH 2 Max. value read data (lower)
	39	CH 3 Max. value read data (upper)
	40	CH 3 Max. value read data (lower)
	41	CH 4 Max. value read data (upper)
	42	CH 4 Max. value read data (lower)
	43	CH 5 Max. value read data (upper)
	44	CH 5 Max. value read data (lower)
	45	CH 6 Max. value read data (upper)
	46	CH 6 Max. value read data (lower)
	47	CH 7 Max. value read data (upper)
	48	CH 7 Max. value read data (lower)

The integrated value of each channel is a non-signed 2-word integer. Be sure to perform writing and reading by 2 word units. The return value at overflow is "0" or "1" (default setting: 0). The maximum range available is 1 000 to 4 294 967 295 (default setting: 9 999 999).

The preset can be set between the return value and the maximum value.

DATA CONVERSION

■ COUNT VALUE

The count value is 32-bit data. It is divided in 2 words of 16 bits represented with 2 addresses. The lower address is allocated in the upper word (MSB) and the upper address in the lower word (LSB). The count value is 0 - 4 294 967 295. The maximum count value available is 1 000 - 4 294 967 295. In case of overflow, the value is reset to 0 or 1 (configurable) from which the count will restart. The preset of the count value is also available. Use the R7CON or host PC/PLC for the configuration.

EXTERNAL DIMENSIONS & TERMINAL ASSIGNMENTS unit: mm [inch]

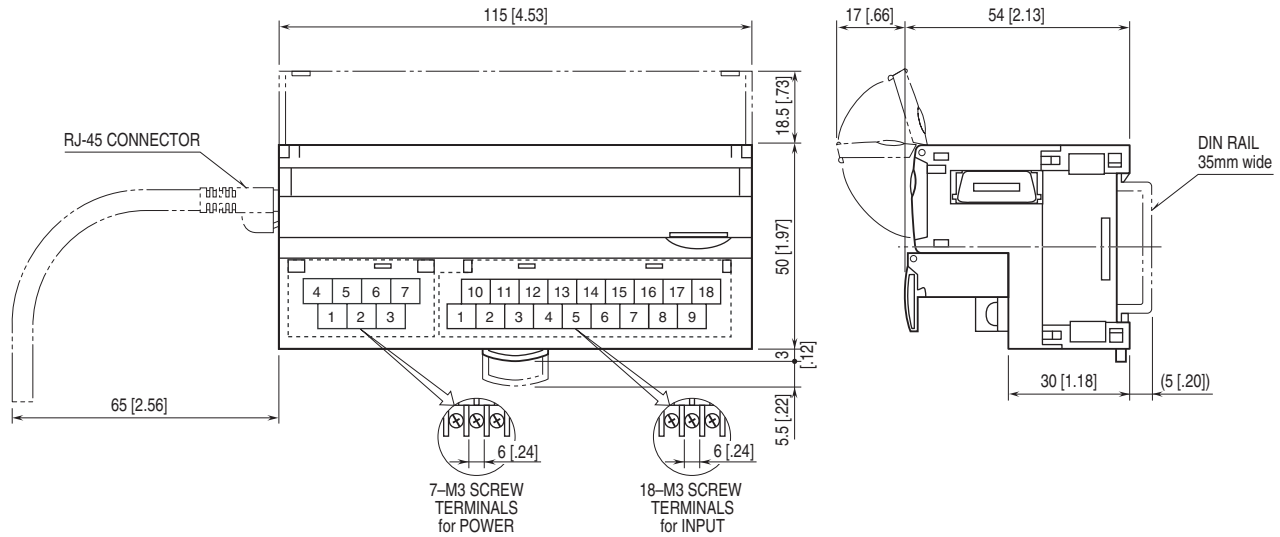

SCHEMATIC CIRCUITRY & CONNECTION DIAGRAM

Caution: FG terminal is NOT a protective conductor terminal.

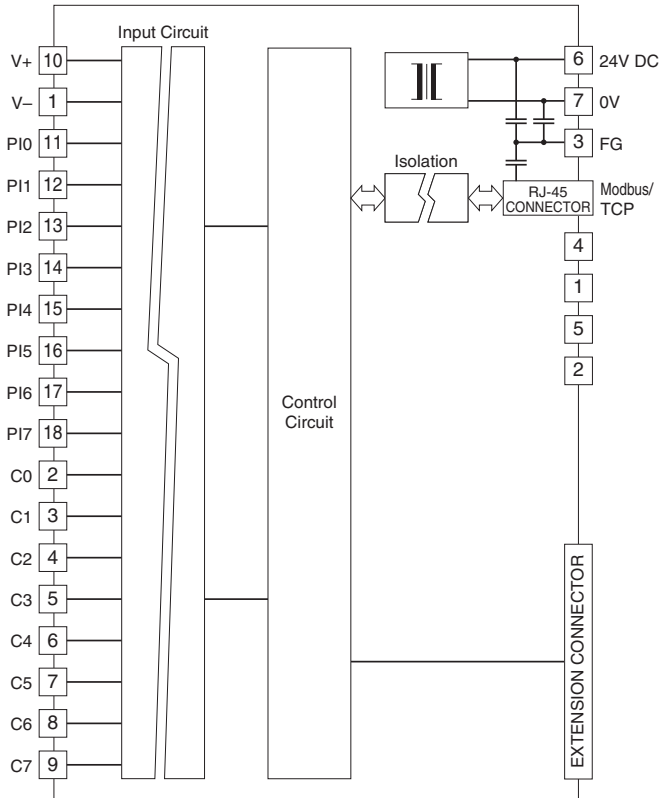

Input Circuit

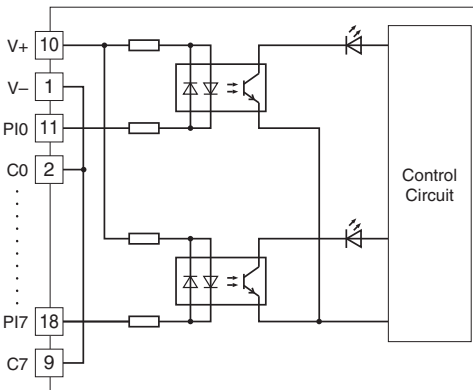

Input Connection Examples

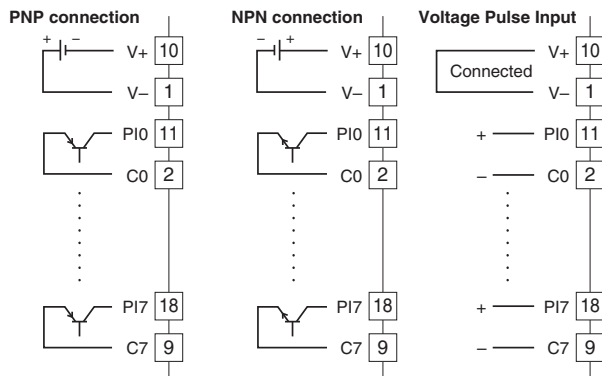



Specifications are subject to change without notice.