

Remote I/O R7 Series

ETHERNET I/O MODULE

(RTD input, 4 points, isolated, Modbus/TCP use)

Functions & Features

- 4 points RTD input module for Modbus/TCP (Ethernet)
- Extension module can be connected
- Input sensor type can be selected with the front DIP switches for all channels.
- Individual channels, zero adjustment, span adjustment, scaling, and temperature unit can be set with the configurator software (model: R7CON)

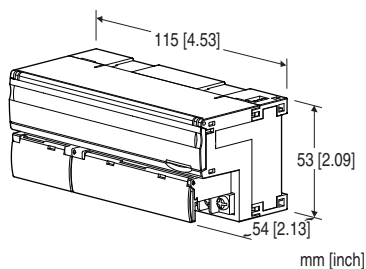

MODEL:R7E-RS4-R[1]

ORDERING INFORMATION

- Code number: R7E-RS4-R[1]
Specify a code from below for [1].
(e.g. R7E-RS4-R/Q)
- Specify the specification for option code /Q
(e.g. /C01/SET)

I/O TYPE

RS4: RTD input, 4 points

POWER INPUT

DC Power

R: 24 V DC

(Operational voltage range 24 V \pm 10 %, ripple 10 %p-p max.)

[1] OPTIONS

blank: none

/Q: With options (specify the specification)

SPECIFICATIONS OF OPTION: Q (multiple selections)

COATING (For the detail, refer to our web site.)

/C01: Silicone coating

/C02: Polyurethane coating

/C03: Rubber coating

EX-FACTORY SETTING

/SET: Preset according to the Ordering Information Sheet
(No. ESU-7807-C)

RELATED PRODUCTS

- PC Configurator cable (model: MCN-CON or COP-US)
- PC configurator software (model: R7CON)
Downloadable at our web site.
- Discrete input extension module (model: R7E-EAx)
- Discrete output extension module (model: R7E-ECx)

Note: PC Configurator Software is required to set IP address.

GENERAL SPECIFICATIONS

Connection

Ethernet: RJ-45 connector

Power, input: M3 separable screw terminal
(torque 0.5 N·m)

Solderless terminal: Refer to the drawing at the end of the section.

Recommended manufacturer: Japan Solderless Terminal MFG. Co., Ltd., Nichifu Co., Ltd.

Applicable wire size: 0.25 to 1.65 mm² (AWG 22 to 16)

Screw terminal: Nickel-plated steel

Housing material: Flame-resistant resin (gray)

Isolation: Input 0 to input 1 to input 2 to input 3 to Ethernet to power to FG

Zero adjustments: Configurable via R7CON

Span adjustments: Configurable via R7CON

Extension: No extension (*), Discrete input 8 or 16 points, Discrete output 8 or 16 points

Selectable with the front DIP SW

(*) Factory default setting

Conversion rate: Selectable with the front DIP SW

Burnout setting: Selectable between upscale (*) and downscale with the front DIP switch

(*) Factory default setting

Linearization: Standard

RTD Setting: Configurable via the front DIP switch or R7CON

Status indicator LEDs: PWR, RUN

Configurator connection: 2.5 dia. miniature jack

■ Recommended solderless terminal

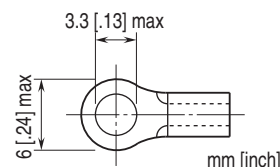

ETHERNET COMMUNICATION

Physical layer standard: IEEE 802.3u
Data link layer: 10BASE-T / 100BASE-TX
Baud rate: 10 / 100 Mbps, Auto Negotiation
Protocol: Modbus/TCP
Data: RTU (binary)
Max. number of socket connections: Two (2)
Transmission media: 10BASE-T (STP cable, category 5)
 100BASE-TX (STP cable, category 5e)
Max. segment length: 100 meters
IP address: Can be set and changed with PC Configurator Software (model: R7CON) (default: 192.168.0.1)
Subnet Mask: Can be set and changed with PC Configurator Software (model: R7CON) (default: 255.255.255.0)
Default Gateway: Can be set and changed with PC Configurator Software (model: R7CON) (Ver.2.41 or later) (default: 192.168.0.100)
Port No.: 502
 DHCP available (Ver.3.00 or later)
Ethernet indicator LEDs: LINK, LINK100, COL

INPUT SPECIFICATIONS

Input resistance: $\geq 1 \text{ M}\Omega$
Maximum leadwire resistance: 100 Ω per wire
Sensing current: $\leq 1 \text{ mA}$

RTD	BURNOUT INDICATION (°C)		CONFORMANCE RANGE (°C)
	Downscale	Upscale	
Pt 100 (JIS '97, IEC)	-240	+900	-200 to +850
Pt 100 (JIS '89)	-240	+900	-200 to +660
JPt 100 (JIS '89)	-236	+560	-200 to +510
Pt 50 Ω (JIS '81)	-236	+700	-200 to +649
Ni 100	-100	+252	-80 to +250
Cu 10 @ 25°C	-212	+312	-50 to +250
Cu 50	-100	+200	-50 to +150

RTD	BURNOUT INDICATION (°F)		CONFORMANCE RANGE (°F)
	Downscale	Upscale	
Pt 100 (JIS '97, IEC)	-400	+1652	-328 to +1562
Pt 100 (JIS '89)	-400	+1652	-328 to +1220
JPt 100 (JIS '89)	-393	+1040	-328 to +950
Pt 50 Ω (JIS '81)	-393	+1292	-328 to +1200
Ni 100	-148	+486	-112 to +482
Cu 10 @ 25°C	-350	+594	-58 to +482
Cu 50	-148	+392	-58 to +302

INSTALLATION

Current consumption
 •DC: Approx. 97 mA
Operating temperature: -10 to +55°C (14 to 131°F)
Storage temperature: -20 to +65°C (-4 to +149°F)
Operating humidity: 30 to 90 %RH (non-condensing)
Atmosphere: No corrosive gas or heavy dust
Mounting: DIN rail (35 mm rail)
Weight: 200 g (0.44 lb)

PERFORMANCE

Conversion accuracy: $\pm 1^\circ\text{C}$ ($\pm 1.8^\circ\text{F}$)
 ($\pm 3^\circ\text{C}$ [$\pm 5.4^\circ\text{F}$] for Cu 10 @ 25°C)
Conversion rate: 250 msec. (*) or 1 sec. selectable
 (*) Factory default setting
Converted data range:
 • Engineering unit value ($^\circ\text{C}$, K) $\times 10$ (integer)
 • Engineering unit value ($^\circ\text{F}$)
Temperature coefficient: $\pm 0.015 \text{ } \%/^\circ\text{C}$ ($\pm 0.008 \text{ } \%/^\circ\text{F}$) of max. span except $\pm 0.150 \text{ } \%/^\circ\text{C}$ ($\pm 0.08 \text{ } \%/^\circ\text{F}$) for Cu 10 @ 25°C
Response time: Conversion rate $\times 2 + 50$ msec. (0 - 90 %)
Insulation resistance: $\geq 100 \text{ M}\Omega$ with 500 V DC
Dielectric strength: 1500 V AC @ 1 minute (input 0 to input 1 to input 2 to input 3 to Ethernet to power to FG)

STANDARDS & APPROVALS

EU conformity:
 EMC Directive
 EMI EN 61000-6-4
 EMS EN 61000-6-2
 RoHS Directive

EXTERNAL VIEW

■ SIDE VIEW

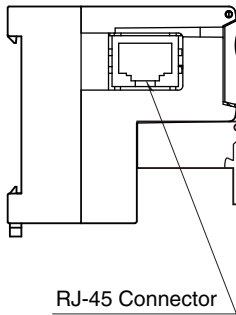

RJ-45 Connector

■ FRONT VIEW

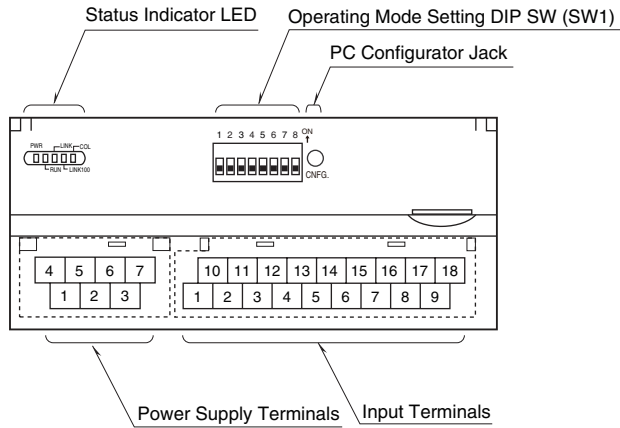

Power Supply Terminals Input Terminals

TERMINAL ASSIGNMENTS

■ INPUT TERMINAL ASSIGNMENT

10	11	12	13	14	15	16	17	18
INA0	INb0	INA1	INb1	NC	INA2	INb2	INA3	INb3
1	2	3	4	5	6	7	8	9
NC	INB0	NC	INB1	NC	NC	INB2	NC	INB3

NO.	ID	FUNCTION	NO.	ID	FUNCTION
1	NC	No connection	10	INA0	RTD 0-A
2	INB0	RTD 0-B	11	INb0	RTD 0-b
3	NC	No connection	12	INA1	RTD 1-A
4	INB1	RTD 1-B	13	INb1	RTD 1-b
5	NC	No connection	14	NC	No connection
6	NC	No connection	15	INA2	RTD 2-A
7	INB2	RTD 2-B	16	INb2	RTD 2-b
8	NC	No connection	17	INA3	RTD 3-A
9	INB3	RTD 3-B	18	INb3	RTD 3-b

■ POWER SUPPLY TERMINAL ASSIGNMENT

4	5	6	7
NC	NC	+24V	0V
1	2	3	
NC	NC	FG	

NO.	ID	FUNCTION, NOTES
1	NC	----
2	NC	----
3	FG	FG
4	NC	----
5	NC	----
6	+24V	Power input (24V DC)
7	0V	Power input (0V)

MODBUS FUNCTION CODES & SUPPORTED CODES

■ **Data and Control Functions**

CODE	NAME	
01	Read Coil Status	Digital output from the slave
02	Read Input Status	Status of digital inputs to the slave
03	Read Holding Registers	General purpose register within the slave
04	Read Input Registers	Collected data from the field by the slave
05	Force Single Coil	Digital output from the slave
06	Preset Single Register	General purpose register within the slave
08	Diagnostics	
11	Fetch Comm. Event Counter	Fetch a status word and an event counter
12	Fetch Comm. Event Log	A status word, an event counter, a message count and a field of event bytes
15	Force Multiple Coils	Digital output from the slave
16	Preset Multiple Registers	General purpose register within the slave
17	Report Slave ID	Slave type/ 'RUN' status

■ **Exception Codes**

CODE	NAME	
01	Illegal Function	Function code is not allowable for the slave
02	Illegal Data Address	Address is not available within the slave
03	Illegal Data Value	Data is not valid for the function

■ **Diagnostic Subfunctions**

CODE	NAME	
00	Return Query Data	Loop back test

MODBUS I/O ASSIGNMENT

	ADDRESS	DATA TYPE	DATA
Coil (0X)	1 – 16		Digital Output (discrete output of the basic module) (unused)
	17 – 32		Digital Output (discrete output of the extension module)
Inputs (1X)	1 – 16		Digital Input (discrete input of the basic module) (unused)
	17 – 32		Digital Input (discrete input of the extension module)
	33 – 48		Reserved (unused)
	49 – 64		Module Status
	65 – 80		Reserved (unused)
Input Registers (3X)	1 – 4	I	Analog Input
	5 – 16	----	Reserved (unused)
	17 – 24	F	Analog Input
	25 – 48	----	Reserved (unused)
Holding Registers (4X)	1 – 48	----	Analog Output (unused)

I : Integer, -1500 – +11500 (-15 – +115%)

F : Floating

Note: DO NOT access addresses other than mentioned above. Such access may cause problems such as inadequate operation.

■ STATUS

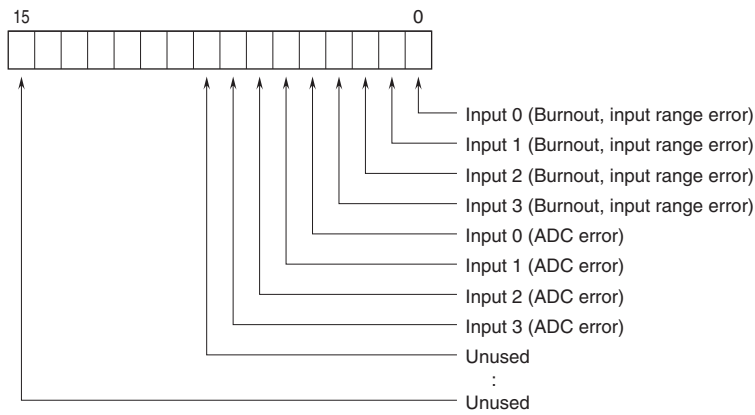

Burnout, input range error ($\leq -15\%$, $\geq +115\%$)

0 : Normal 1 : Error

ADC error (no response from ADC)

0 : Normal 1 : Error

DATA CONVERSION

■ INPUT RANGE AND DATA CONVERSION (FACTORY DEFAULT SETTING)

Engineering unit value °C or K is multiplied by 10 and expressed in 16 bits. °F data is represented in engineering unit value, without multiplication. Negative value is represented in 2's complements.

- Input TYPE K Thermocouple

Input Value	Converted Data, Decimal	Converted Data, Hex
≤ -272°C	-2720	F560
-150°C	-1500	FA24
1370°C	13700	3584
≥ 1472°C	14720	3980

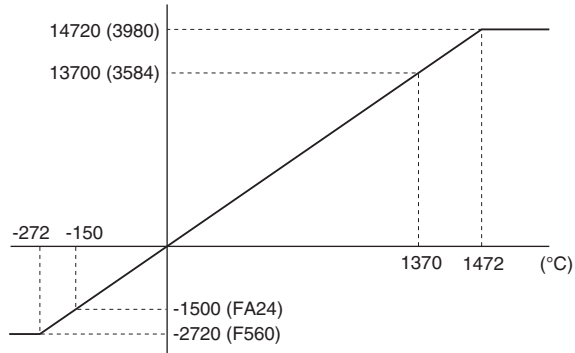

EXTERNAL DIMENSIONS & TERMINAL ASSIGNMENTS unit: mm [inch]

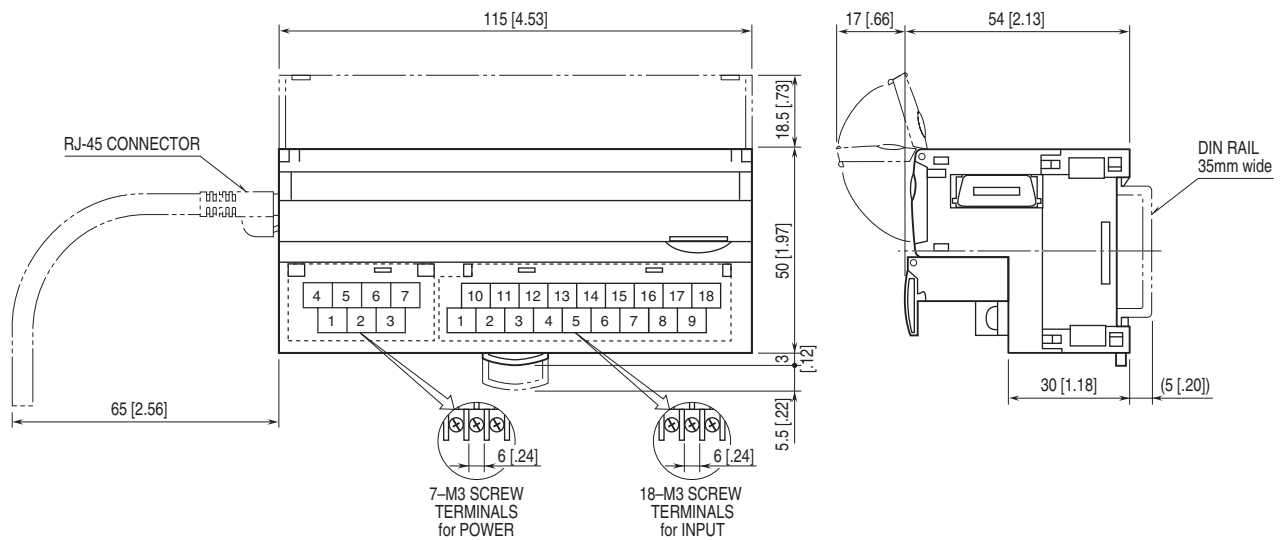

SCHEMATIC CIRCUITRY & CONNECTION DIAGRAM

Note: In order to improve EMC performance, bond the FG terminal to ground.

Caution: FG terminal is NOT a protective conductor terminal.

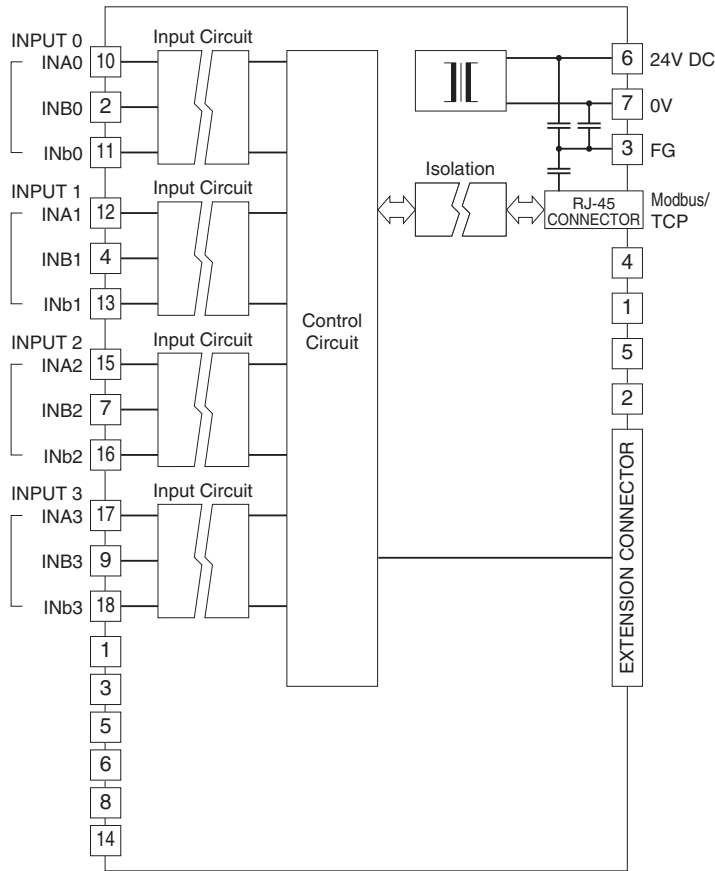

■ Input Connection Example

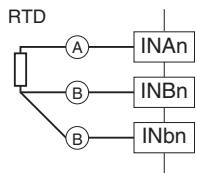

Specifications are subject to change without notice.