

## Remote I/O R7 Series

### MULTI POWER MONITORING MODULE

(Clamp-on current sensor CLSE, Modbus/TCP)

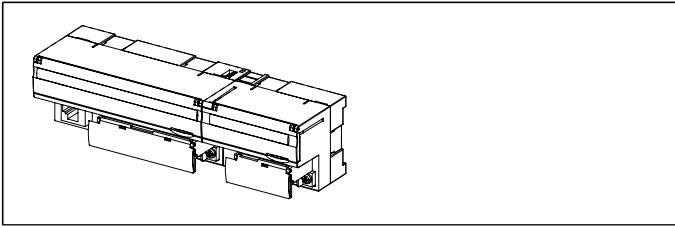

### MODEL: R7EWTU-2[1]1-AD4[2]

#### ORDERING INFORMATION

- Code number: R7EWTU-2[1]1-AD4[2]  
Specify a code from below for each of [1] and [2].  
(e.g. R7EWTU-221-AD4/Q)
- Specify the specification for option code /Q  
(e.g. /C01/SET)

#### CONFIGURATION

- 2: Single phase / 2-wire and 3-wire,  
3-phase / 3-wire and 4-wire

#### [1] NO. OF SYSTEMS

- 1: 1 system, Di / Pi x 4 points (internal power 5 V)  
2: 2 systems

#### INPUT

- 1: 240 V AC / CLSE

#### POWER INPUT

Universal

**AD4:** 100 - 240 V AC / 110 - 240 V DC (universal)  
(Operational voltage range 85 - 264 V AC, 50 - 60 Hz /  
99 - 264 V DC, ripple 10 %p-p max.)

#### [2] OPTIONS

- blank:** none  
**/Q:** With options (specify the specification)

#### SPECIFICATIONS OF OPTION: Q

COATING (For the detail, refer to our web site.)  
**/C01:** Silicone coating  
**/C02:** Polyurethane coating  
**/C03:** Rubber coating  
EX-FACTORY SETTING

**/SET:** Preset according to the Ordering Information Sheet  
(No. ESU-7818-x)

#### FUNCTIONS & FEATURES

The R7EWTU is a Multi Power Monitoring Module for Modbus/TCP.

The R7EWTU uses clamp-on current sensors, there is no need of current transformers.

Current sensors are easy to install in existing systems. Wide input range of 5 to 600 A is available.

All measured values, counter values, display mode, setting data are stored in the non-volatile memory when power is off.

#### RELATED PRODUCTS

- PC configurator software (model: PMCFG)  
Downloadable at our web site.  
A dedicated cable is required to connect the module to the PC. Please refer to the internet software download site or the users manual for the PC configurator for applicable cable types.
- Clamp-on current sensor (model: CLSE)  
The clamp-on current sensors, not included in this product package, must be ordered separately. Required number depends upon the system configuration.

#### GENERAL SPECIFICATIONS

##### Connection

**Ethernet:** RJ-45 connector

**Power, input:** M3 separable screw terminal  
(torque 0.5 N·m)

**Solderless terminal:** Refer to the drawing at the end of the section.

**Recommended manufacturer:** Japan Solderless Terminal MFG.Co.Ltd, Nichifu Co.,Ltd

**Applicable wire size:** 0.25 to 1.65 mm<sup>2</sup> (AWG 22 to 16)

**Configuration:** Single phase/2-wire and 3-wire, 3-phase/3-wire balanced/unbalanced load, 3-phase/4-wire balanced/unbalanced load

**Screw terminal:** Nickel-plated steel

**Housing material:** Flame-resistant resin (gray)

**Isolation:** Sensor core to sensor output or current input or voltage input to discrete input to Ethernet or FG to power

##### Measured variables

**Voltage:** 1-N, 2-N, 3-N, 1-2, 2-3, 3-1

**Current:** 1, 2, 3, N

**Active / reactive / apparent power:** 1, 2, 3,  $\Sigma$

**Power factor:** 1, 2, 3,  $\Sigma$

##### Frequency

**Active energy:** Incoming / outgoing

**Reactive energy:** Incoming / outgoing / lag (inductive)

/lead (capacitive)

**Apparent energy**

**Active / reactive / apparent power intervals (demand)**

**Average (demand) current:** 1, 2, 3, N

**Harmonic contents:**  $\Sigma$

Voltage: 1-N, 2-N, 3-N, 1-2, 2-3, 3-1

Current: 1, 2, 3, N

**Max. and min. values**

**Demand history:** 1 to 4

**Operating mode setting:** Connection, clamp-on sensor selection

**Status indicator LED:** PWR, RUN

**User-configurable items:** Front DIP SW

- Connection configuration
- Balanced/unbalanced
- Clamp sensor range
- Configuration method

(Refer to the manual for details)

■ Recommended solderless terminal size - M3

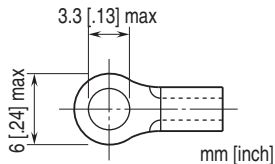

## ETHERNET COMMUNICATION

**Communication Standard:** IEEE 802.3u

**Transmission:** 10BASE-T, 100BASE-TX

**Baud rate:** 10/100 Mbps (Auto Negotiation function)

**Protocol:** Modbus/TCP

**Data:** RTU (Binary)

**Max. number of socket connections:** 2

**Connection:** RJ-45 modular jack

**Transmission media:** 10BASE-T (STP, Category 5) 100BASE-TX (STP, Category 5e)

**Max. length of fieldbus segment:** 100 meters

**IP address:** 192.168.0.1 (factory default)

Configurable with software (model: PMCFG)

**Port number:** 502

**Ethernet status indicator:** LINK, LINK100, COL

## INPUT SPECIFICATIONS

**Frequency:** 50 / 60 Hz (45 - 65 Hz)

• **Voltage Input**

**Rated voltage**

Line-to-line (delta voltage): 240 V

Line-neutral (phase voltage): 138 V (three-phase/4-wire)

**Consumption VA:**  $\leq U_{LN}^2 / 300 \text{ k}\Omega / \text{phase}$

**Overload capacity:** 200 % of rating for 10 sec., 120 % continuous

**Selectable primary voltage range:** 50 - 400 000 V

• **Current Input**

**CLSE-R5:** 0 - 5 A AC

**CLSE-05:** 0 - 50 A AC

**CLSE-10:** 0 - 100 A AC

**CLSE-20:** 0 - 200 A AC

**CLSE-40:** 0 - 400 A AC

**CLSE-60:** 0 - 600 A AC

**Overload capacity:** 120 % continuous, 500 % for 10 sec.

(Note: Use for the circuit not exceed 480 V)

**Selectable primary current range:** 1 - 20 000 A (only with CLSE-R5, refer to the configurator settings)

**Operational range**

**Current:** 0 - 120 % of the rating

**Voltage:** 10 - 120 % of the rating

**Apparent power:**  $\leq 120$  % of the rating

**Active/reactive power:**  $\pm 120$  % of the rating

**Frequency:** 45 - 65 Hz

**Power factor:**  $\pm 1$

■ **Discrete input**

**Common:** Negative common

**Maximum frequency:** 10 Hz

**Minimum pulse width:** 50 msec.

**Totalized pulse range:** 0 - 999 999 999

**Count at overflow:** Reset and restart at '1.'

**Detecting voltage/current:** 5 V DC / 5 mA approx.

**Detecting levels:**  $\leq 5 \text{ k}\Omega / \leq 2 \text{ V}$  for ON;

$\geq 100 \text{ k}\Omega / 4 \text{ V}$  for OFF

**Operation mode:** Discrete and pulse counter

## INSTALLATION

**Power consumption**

• **AC:**  $< 8 \text{ VA}$

• **DC:**  $< 3 \text{ W}$

**Operating temperature:** -10 to +55°C (14 to 131°F)

**Storage temperature:** -20 to +65°C (-4 to +149°F)

**Operating humidity:** 30 to 90 %RH (non-condensing)

**Atmosphere:** No corrosive gas or heavy dust

**Mounting:** DIN rail

**Weight:** 300 g (0.66 lb)

## PERFORMANCE

**Accuracy** (at 10 - 35°C or 50 - 35°F, 45 - 65 Hz)

Add the accuracy of the current sensor for overall values.

**Voltage:**  $\pm 0.5$  % of the rating

**Current:**  $\pm 0.5$  % of the rating

**Power:**  $\pm 1.0$  % of the rating

**Power factor:**  $\pm 1.5$  %

**Frequency:**  $\pm 0.1$  % of the rating

**Energy:**  $\pm 2.0$  % of the rating (range 5 - 100 %, PF 1)

**Harmonic contents:**  $\pm 2.0$  % of the rating

The described accuracy levels are ensured at the input 1 %

or more for phase 2 current with 3-phase/3-wire unbalanced load, for neutral current with 3-phase/4-wire unbalanced load, and neutral current with 1-phase/3-wire.

**Data update period:**

**Harmonic contents and frequency:** ≤ 1 sec.

**Other:** ≤ 500 msec.

**Insulation resistance:** ≥ 100 MΩ with 500 V DC

**Dielectric strength:**

1500 V AC @ 1 minute (Current input or voltage input or discrete input to Ethernet to power supply to FE1)

1000 V AC @ 1 minute (Sensor output or current input or voltage input to discrete input)

## EXTERNAL VIEW

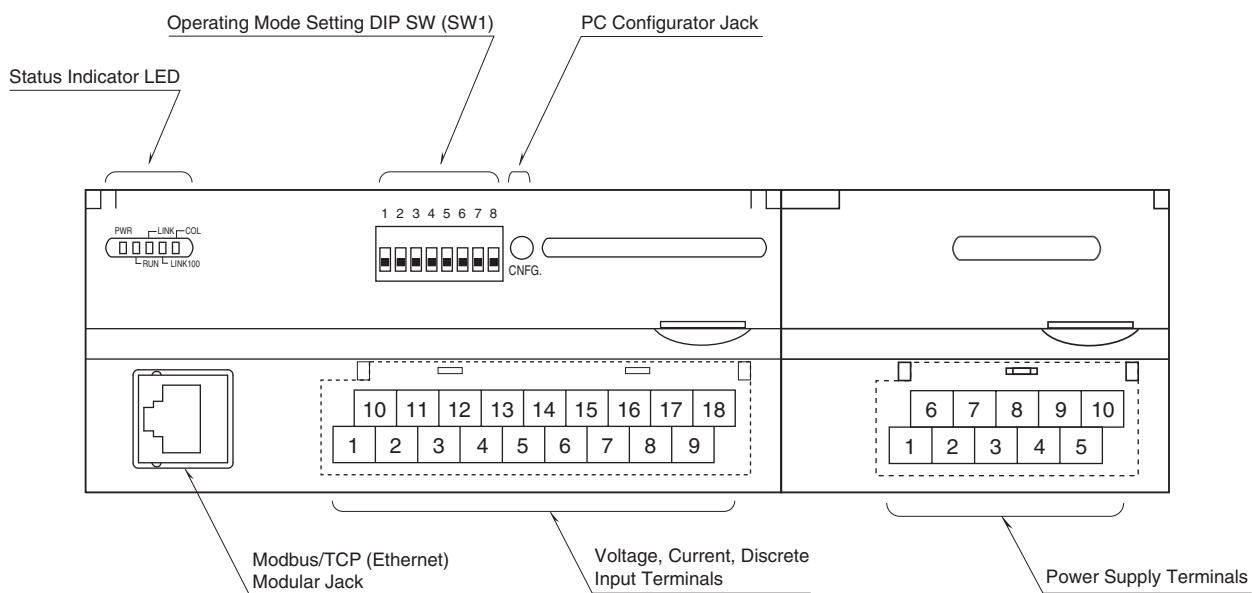

**■ STATUS INDICATOR LED**

LED	COLOR	STATUS	OPERATION
PWR	Red	ON	Normal operating
		Blink ≈0.5 Hz	No input or input overflow
		Blink ≈2 Hz	Setting error or device abnormality
		OFF	Internal power 5V abnormality
RUN	Red	ON	Normal communication
LINK	Red	ON	On with LINK on
LINK100	Red	Blink	Blink in 100BASE communication
COL	Red	Blink	Blink in collision

## TERMINAL CONNECTIONS

System / Application	Terminal	System / Application	Terminal
Single phase / 2-wire		Single phase / 3-wire Three phase / 3-wire unbalanced load (2CT)	
Three phase / 3-wire, balanced load		Three phase / 4-wire, balanced load	
Three phase / 4-wire, unbalanced load			

Note: Use CLSE for CT.  
Grounding is unnecessary for low-voltage circuit.

## TERMINAL ASSIGNMENTS

### • 1 Circuit, 4 point discrete

10	11	12	13	14	15	16	17	18
P3	NC	NC	1K	2K	3K	DI1+	DI3+	COM
1	2	3	4	5	6	7	8	9
P1	P2	N	1L	2L	3L	DI2+	DI4+	COM

### • 2 Circuits

10	11	12	13	14	15	16	17	18
P3	NC	NC	1K	2K	3K	1K	2K	3K
1	2	3	4	5	6	7	8	9
P1	P2	N	1L	2L	3L	1L	2L	3L

PIN No.	ID	FUNCTION	PIN No.	ID	FUNCTION
1	P1	Voltage Input P1	10	P3	Voltage Input P3
2	P2	Voltage Input P2	11	NC	Unused
3	N	Voltage Input N	12	NC	Unused
4	1ch 1L	1ch current input 1L	13	1ch 1K	1ch current input 1K
5	1ch 2L	1ch current input 2L	14	1ch 2K	1ch current input 2K
6	1ch 3L	1ch current input 3L	15	1ch 3K	1ch current input 3K
7	DI2 +	Discrete input 2	16	DI1 +	Discrete input 1
8	DI4 +	Discrete input 4	17	DI3 +	Discrete input 3
9	COM	Discrete input common	18	COM	Discrete input common

PIN No.	ID	FUNCTION	PIN No.	ID	FUNCTION
1	P1	Voltage Input P1	10	P3	Voltage Input P3
2	P2	Voltage Input P2	11	NC	Unused
3	N	Voltage Input N	12	NC	Unused
4	1ch 1L	1ch current input 1L	13	1ch 1K	1ch current input 1K
5	1ch 2L	1ch current input 2L	14	1ch 2K	1ch current input 2K
6	1ch 3L	1ch current input 3L	15	1ch 3K	1ch current input 3K
7	2ch 1L	2ch current input 1L	16	2ch 1K	2ch current input 1K
8	2ch 2L	2ch current input 2L	17	2ch 2K	2ch current input 2K
9	2ch 3L	2ch current input 3L	18	2ch 3K	2ch current input 3K

### ■ POWER SUPPLY

6	7	8	9	10
NC	NC	NC	NC	NC
1	2	3	4	5
NC	NC	FE1	U+	V-

PIN No.	ID	FUNCTION	PIN No.	ID	FUNCTION
1	NC	Unused	6	NC	Unused
2	NC	Unused	7	NC	Unused
3	FE1	Power ground	8	NC	Unused
4	U+	Power input +	9	NC	Unused
5	V-	Power input -	10	NC	Unused

## DIMENSIONS unit: mm (inch)

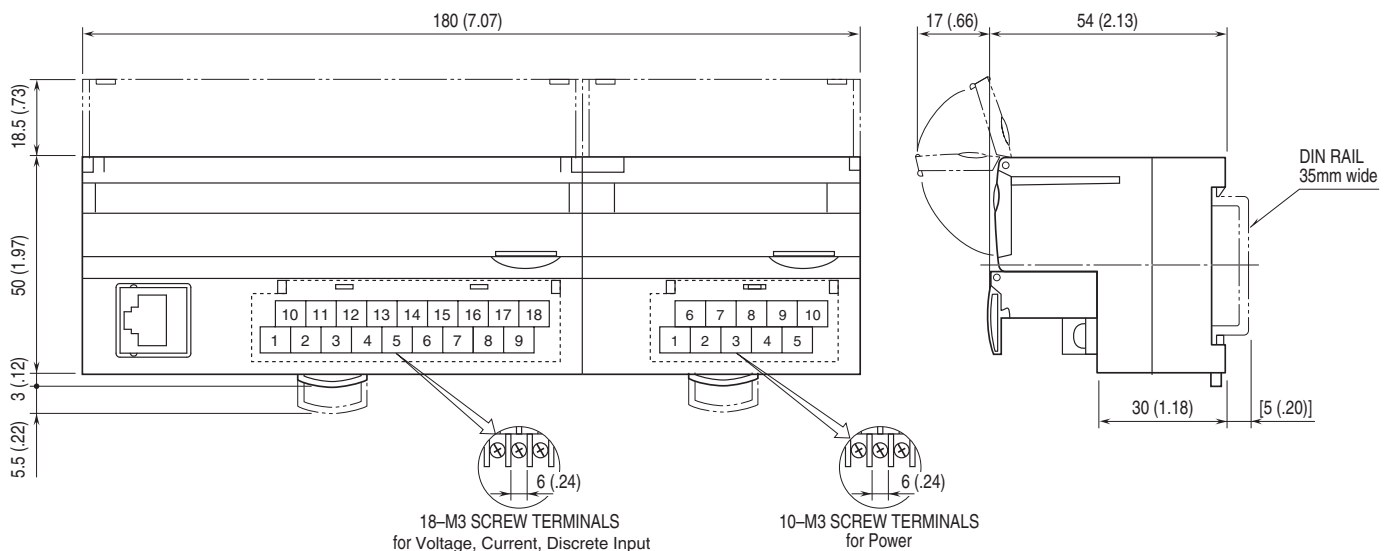

## SCHEMATIC CIRCUITRY & CONNECTION DIAGRAM

### • 1 Circuit, 4-point Discrete Input

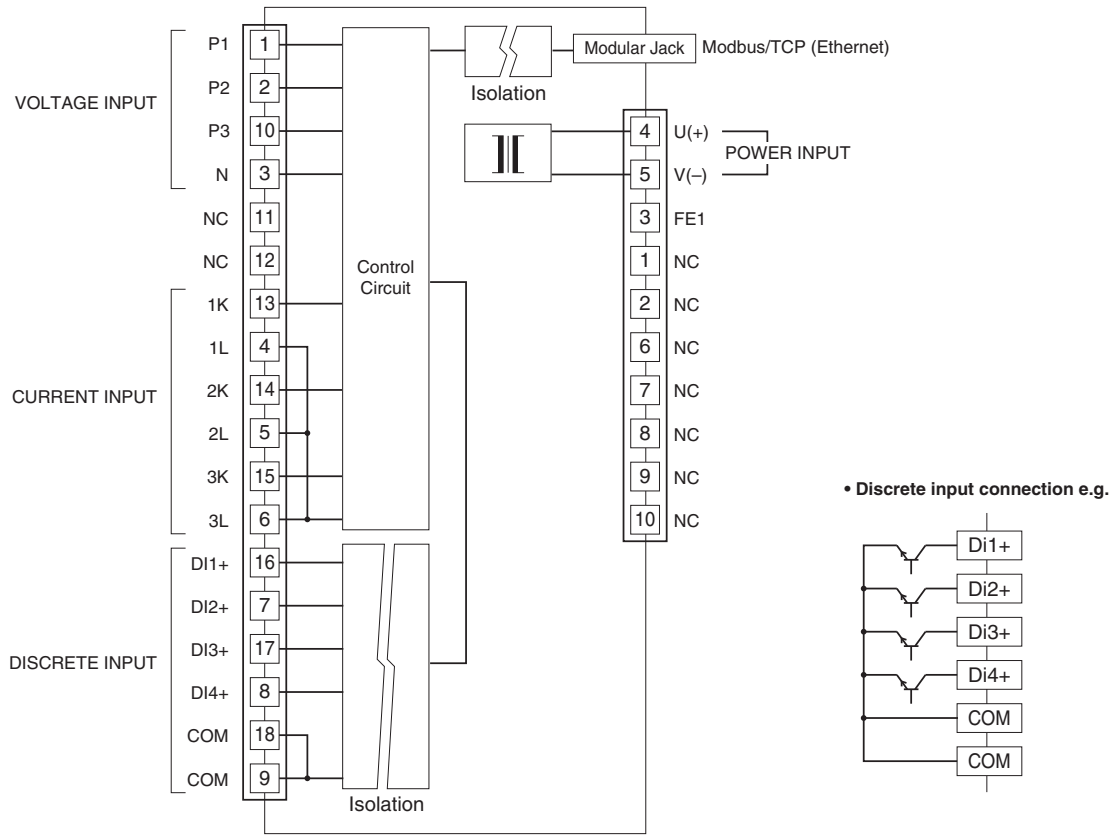

### • 2 Circuits

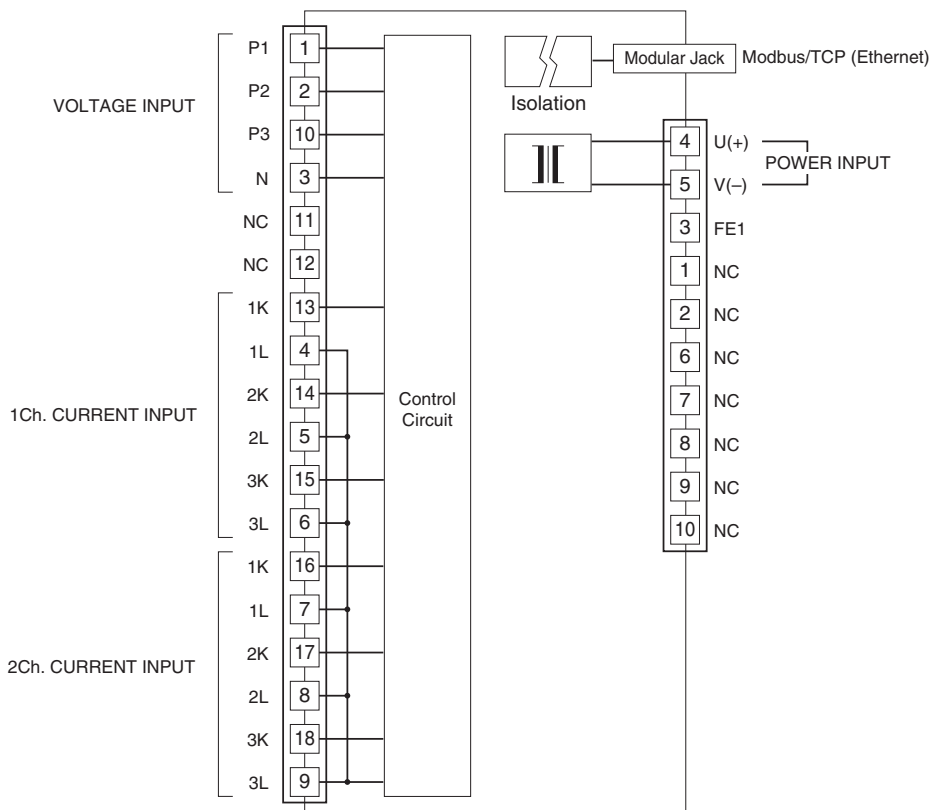



Specifications are subject to change without notice.