

Remote I/O R7F4D Series

/C03: Rubber coating

CC-Link I/O MODULE

(PNP transistor output, 16 points each, e-CON connector)

Functions & Features

- Interchanges discrete I/O signals with the fieldbus (CC-Link)

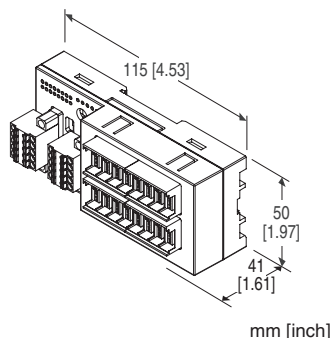

MODEL: R7F4DC-DC16B-H-R[1]

ORDERING INFORMATION

- Code number: R7F4DC-DC16B-H-R[1]
Specify a code from below for [1].
(e.g. R7F4DC-DC16B-H-R/Q)
- Specify the specification for option code /Q
(e.g. /C01)

I/O TYPE

DC16B: PNP transistor output, 16 points

TERMINAL BLOCK

H: Tension clamp terminal block for power
Tension clamp terminal block for communication
e-CON connector for output

POWER INPUT

DC Power
R: 24 V DC
(Operational voltage range 24 V \pm 10 %, ripple 10 %p-p max.)

[1] OPTIONS

blank: none
/Q: With options (specify the specification)

SPECIFICATIONS OF OPTION: Q

COATING (For the detail, refer to our web site.)
/C01: Silicone coating
/C02: Polyurethane coating

RELATED PRODUCTS

- CSP+ file
The CSP+ file are downloadable at our web site.
CSP+ file is also downloadable at CC-Link Partner Association's web site.

GENERAL SPECIFICATIONS

Connection

CC-Link: Tension clamp terminal block
Power supply, exc. supply: Tension clamp terminal
Output: e-CON connector

Housing material: Flame-resistant resin (gray)

Isolation: Output or exc. supply to CC-Link to power supply to FE1

Discrete output status indicator LED: Green LED; turns on with output ON

CC-Link COMMUNICATION

Transmission: CC-Link ver.1.10

Network cable: CC-Link cable designated by Mitsubishi Electric

Station type: Remote I/O device

Station number: 1 - 64 (rotary switch, default:00)

Baud rate setting: 156 kbps (default), 625 kbps, 2.5 Mbps, 5 Mbps, 10 Mbps (DIP switch)

Terminating resistor: Built-in (DIP Switch, default: disable)

Status indicator LEDs: Power, Run, Error, SD, RD

For details, refer to the users manual.

OUTPUT SPECIFICATIONS

Common: Positive common (PNP) per 16 points

Number of output: 16 points

Maximum outputs applicable at once: No limit (at 24 V DC)

Rated load voltage: 24 V DC \pm 10 %, ripple 5 %p-p max., \leq 1 A (including discrete output load charge); rated current 8 A

Rated output current: 0.1 A per point, 1.6 A per common

Residual voltage: \leq 1.2 V

Leakage current: \leq 0.1 mA

ON delay: \leq 0.2 msec.

OFF delay: \leq 0.5 msec.

With shortcircuit protection

With overheat protection

(When driving an inductive load, connect a diode in parallel with the load.)

INSTALLATION

Current consumption

•DC: Approx. 35 mA

(contact I/O load charge is not included)

Operating temperature: -10 to +55°C (14 to 131°F)

Storage temperature: -20 to +65°C (-4 to +149°F)

Operating humidity: 30 to 90 %RH (non-condensing)

Atmosphere: No corrosive gas or heavy dust

Mounting: Surface or DIN rail (35 mm rail)

Weight: 120 g (0.26 lb)

PERFORMANCE

Insulation resistance: $\geq 100 \text{ M}\Omega$ with 500 V DC

Dielectric strength: 1500 V AC @ 1 minute

(output or exc. supply to communication/power supply)

STANDARDS & APPROVALS

EU conformity:

EMC Directive

EMI EN 61000-6-4

EMS EN 61000-6-2

RoHS Directive

EXTERNAL VIEW

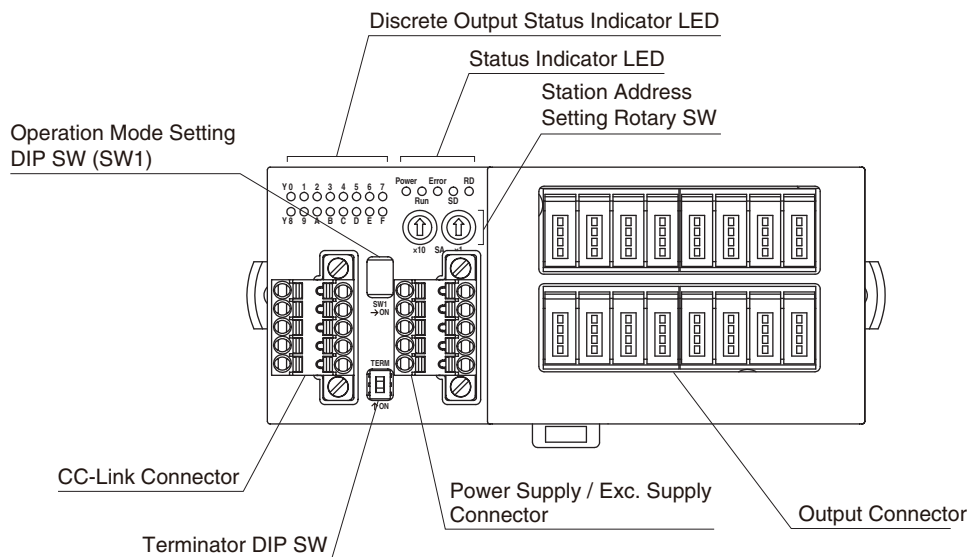

COMMUNICATION CABLE WIRING

■ MASTER CONNECTION

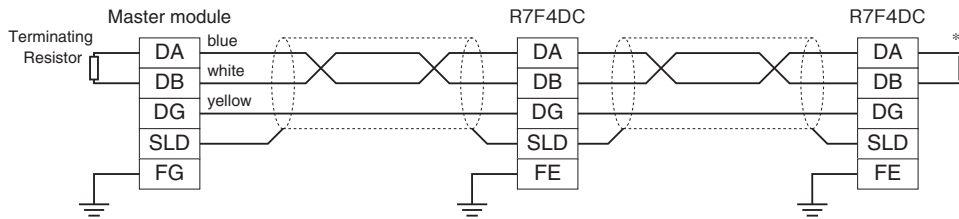

*1. Turn on the terminator DIP switch to activate the internal terminating resistor.

TERMINAL ASSIGNMENTS

■ CC-Link, POWER SUPPLY, EXC. SUPPLY ASSIGNMENT

Unit side connector: MCV1,5/5-GF-3,5 (Phoenix contact)

Cable side connector: TFMC1,5/5-STF-3,5 (Phoenix contact)

Applicable wire size: 0.2 - 1.5mm²

Stripped length: 10mm

Recommended solderless terminal:

AI0,25-10YE 0.25mm² (Phoenix contact)

AI0,34-10TQ 0.34mm² (Phoenix contact)

AI0,5-10WH 0.5mm² (Phoenix contact)

AI0,75-10GY 0.75mm² (Phoenix contact)

AI1-10 1.0mm² (Phoenix contact)

AI1,5-10 1.5mm² (Phoenix contact)

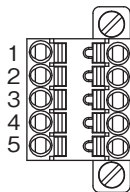

· CC-Link

PIN NO.	ID	FUNCTION
1	FE	Function earth
2	SLD	Shield
3	DB	DB
4	DG	DG
5	DA	DA

· POWER SUPPLY / EXC. SUPPLY

PIN NO.	ID	FUNCTION
1	PWR+	Power supply +
2	PWR-	Power supply -
3	FE1	Grounding
4	SNSR.EXC+	Exc. supply +
5	SNSR.EXC-	Exc. supply -

Note: The numbers marked on the connector have no relationship to the pin number of the unit. Wire according to the instruction manual of the unit.

■ OUTPUT TERMINAL ASSIGNMENT

MODEL: R7F4DC-DC16B-H

Unit side connector: 37216-62M3-004PL (3M company)
 Cable side connector: 37104-()-000FL (3M company)
 (The cable connector is not included in the package.)
 Specify wire size instead of (); refer to the specifications of the product.)

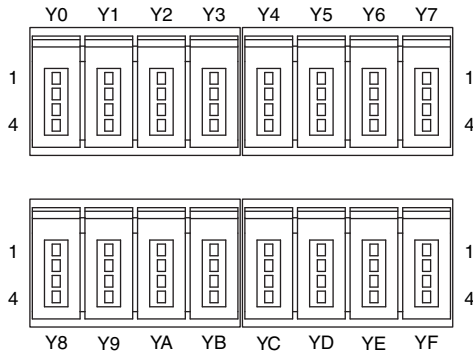

PIN NO.	ID	FUNCTION	PIN NO.	ID	FUNCTION
Y0	1	NC	Y8	1	NC
	2	NC		2	NC
	3	GND		3	GND
	4	Y0		4	Y8
Y1	1	NC	Y9	1	NC
	2	NC		2	NC
	3	GND		3	GND
	4	Y1		4	Y9
Y2	1	NC	YA	1	NC
	2	NC		2	NC
	3	GND		3	GND
	4	Y2		4	YA
Y3	1	NC	YB	1	NC
	2	NC		2	NC
	3	GND		3	GND
	4	Y3		4	YB
Y4	1	NC	YC	1	NC
	2	NC		2	NC
	3	GND		3	GND
	4	Y4		4	YC
Y5	1	NC	YD	1	NC
	2	NC		2	NC
	3	GND		3	GND
	4	Y5		4	YD
Y6	1	NC	YE	1	NC
	2	NC		2	NC
	3	GND		3	GND
	4	Y6		4	YE
Y7	1	NC	YF	1	NC
	2	NC		2	NC
	3	GND		3	GND
	4	Y7		4	YF

DATA ALLOCATION

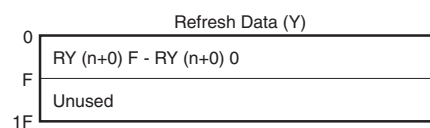
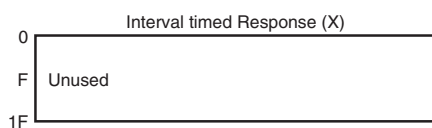

I/O DATA DESCRIPTIONS

■ DISCRETE OUTPUT

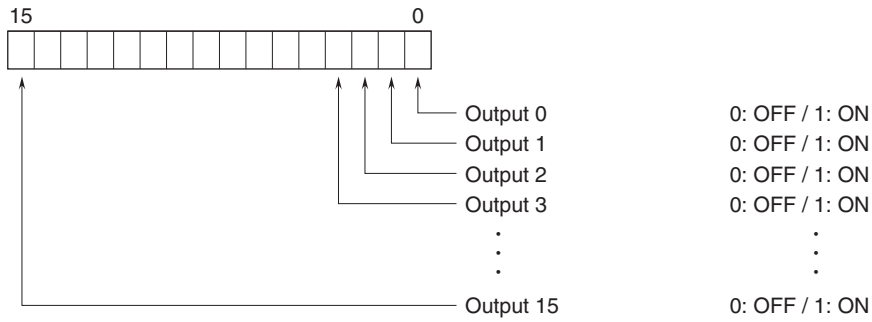

EXTERNAL DIMENSIONS unit: mm [inch]

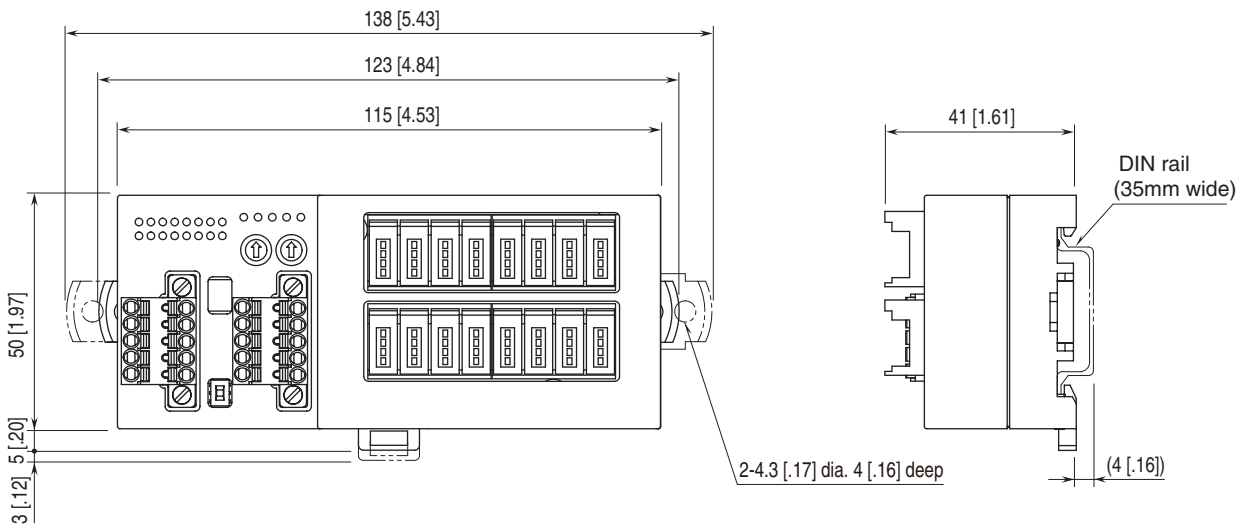

MOUNTING REQUIREMENTS unit: mm [inch]

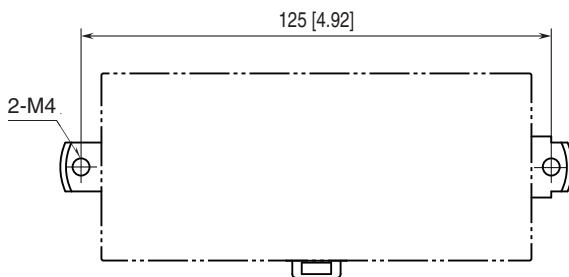

SCHEMATIC CIRCUITRY & CONNECTION DIAGRAM

Note: In order to improve EMC performance, bond the FE1 terminal to ground.

Caution: FE1 terminal is NOT a protective conductor terminal.

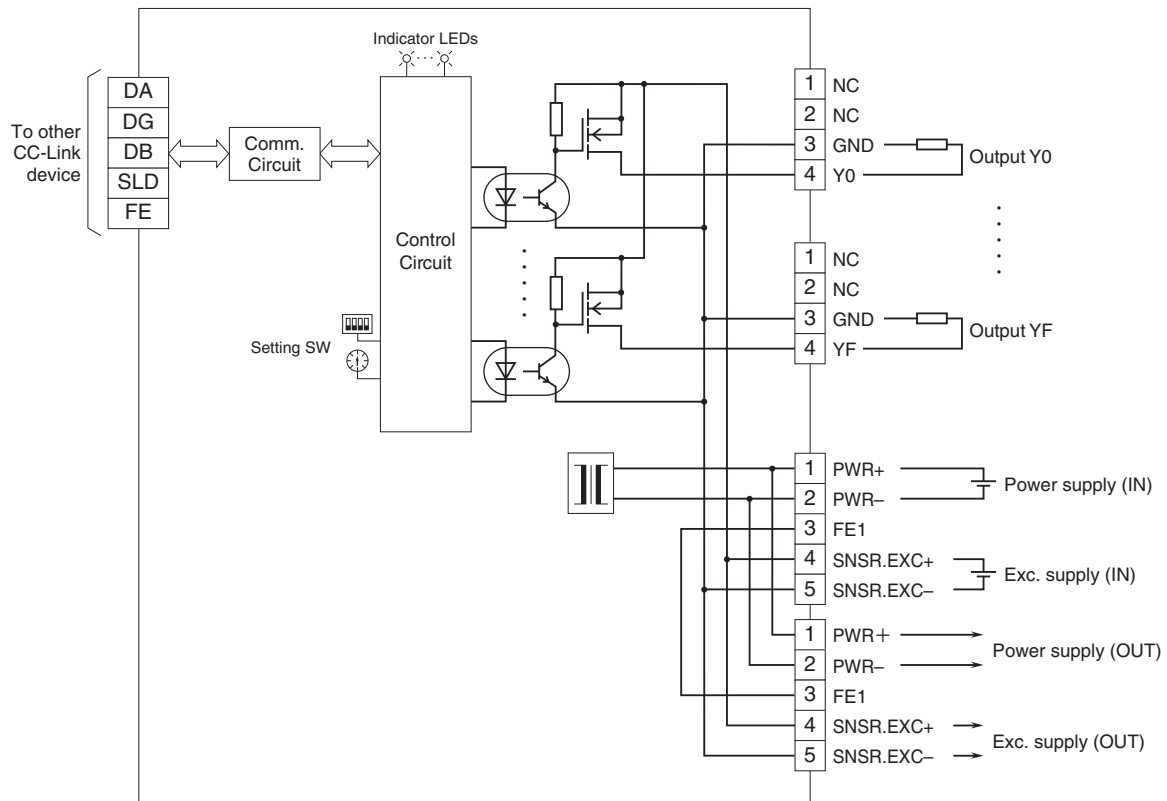

Specifications are subject to change without notice.