

## Remote I/O R7F4H Series

### CC-Link I/O MODULE

(NPN/PNP discrete input, PNP discrete output, 16 points each, FCN connector)

#### Functions & Features

- Remote I/O module to input/output digital I/O signal to field bus (CC-Link)

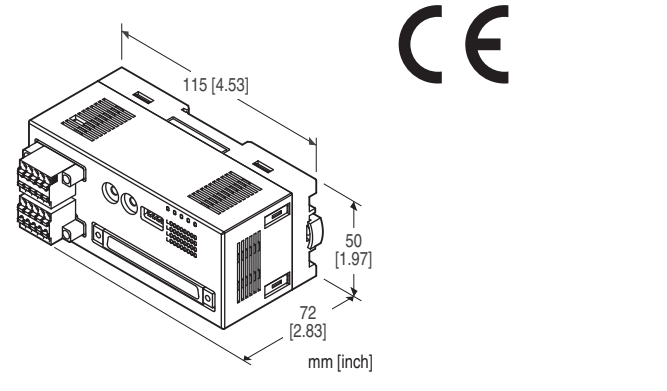

### MODEL: R7F4HC-DAC32D-K-R[1]

#### ORDERING INFORMATION

- Code number: R7F4HC-DAC32D-K-R[1]  
Specify a code from below for [1].  
(e.g. R7F4HC-DAC32D-R/Q)
- Specify the specification for option code /Q  
(e.g. /C01)

#### I/O TYPE

**DAC32D:** NPN/PNP discrete input & PNP discrete output, 16 points each

#### TERMINAL BLOCK

**K:** Tension clamp terminal block for power supply  
Tension clamp terminal block for power supply for communication  
FCN connector for I/O

#### POWER INPUT

DC Power  
**R:** 24 V DC  
(Operational voltage range 24 V  $\pm$ 10 %, ripple 10 %p-p max.)

#### [1] OPTIONS

**blank:** none  
**/Q:** With options (specify the specification)

#### SPECIFICATIONS OF OPTION: Q

COATING (For the detail, refer to our web site.)  
**/C01:** Silicone coating  
**/C02:** Polyurethane coating  
**/C03:** Rubber coating

#### RELATED PRODUCTS

- CSP+ file  
The CSP+ file are downloadable at our web site.  
CSP+ file is also downloadable at CC-Link Partner Association's web site.

#### GENERAL SPECIFICATIONS

**Connection**  
**CC-Link:** Tension clamp terminal block  
**Power supply:** Tension clamp terminal block  
**I/O signal, exc. supply:** FCN connector  
**Housing material:** Flame-resistant resin (gray)  
**Isolation:** I/O or exc. supply to CC-Link to power supply to FE1  
**Discrete I/O status indicator LED:** Green LED turns on with I/O ON

#### CC-Link COMMUNICATION

**Transmission:** CC-Link Ver.1.10  
**Network cable:** CC-Link cable designated by Mitsubishi Electric  
**Station Type:** Remote I/O device  
**Data allocation:** 1  
**Station number:** 1 - 64 (rotary switch, default:00)  
**Baud rate setting:** 156 kbps (default), 625 kbps, 2.5 Mbps, 5 Mbps, 10 Mbps (DIP switch)  
**Terminating resistor:** Built-in (DIP Switch, default: disable)  
**Status indicator LEDs:** Power, Run, Error, SD, RD  
For details, refer to the users manual.

#### INPUT SPECIFICATIONS

**Common:** Positive or negative common (NPN/PNP) per 16 points  
**Number of inputs:** 16  
**Maximum inputs applicable at once:** No limit (at 24 V DC)  
**Rated input voltage:** 24 V DC  $\pm$ 10 %; ripple 5 %p-p max.  
**ON voltage / current:**  $\geq$  17 V DC (input - COM) /  $\geq$  2.3 mA  
**OFF voltage / current:**  $\leq$  5 V DC (input - COM) /  $\leq$  0.75 mA  
**Input current:**  $\leq$  3.5 mA per point at 24 V DC  
**Input resistance:** Approx. 7.2 k $\Omega$   
**ON delay:**  $\leq$  0.5 msec.  
**OFF delay:**  $\leq$  0.5 msec.

## OUTPUT SPECIFICATIONS

**Common:** Positive common (PNP) per 16 points  
**Number of output:** 16 points  
**Maximum outputs applicable at once:** No limit (at 24 V DC)  
**Rated load voltage:** 24 V DC  $\pm 10\%$ , ripple 5 %p-p max.  
**Rated output current:** 0.1 A per point, 1.6 A per common  
**Residual voltage:**  $\leq 1.2$  V  
**Leakage current:**  $\leq 0.1$  mA  
**ON delay:**  $\leq 0.2$  msec.  
**OFF delay:**  $\leq 0.5$  msec.  
With shortcircuit protection  
With overheat protection  
(When driving an inductive load, connect a diode in parallel with the load.)

## INSTALLATION

**Current consumption**  
• DC (@ 24 V DC):  $\leq 50$  mA  
(contact I/O load charge is not included)  
**Operating temperature:** -10 to +55°C (14 to 131°F)  
**Storage temperature:** -20 to +65°C (-4 to +149°F)  
**Operating humidity:** 30 to 90 %RH (non-condensing)  
**Atmosphere:** No corrosive gas or heavy dust  
**Mounting:** Surface or DIN rail (35 mm rail)  
**Weight:** 160 g (0.35 lb)

## PERFORMANCE

**Insulation resistance:**  $\geq 100$  M $\Omega$  with 500 V DC  
**Dielectric strength:** 1500 V AC @ 1 minute  
(I/O or exc. supply to CC-Link to power supply to FE1)

## STANDARDS & APPROVALS

**EU conformity:**  
EMC Directive  
EMI EN 61000-6-4  
EMS EN 61000-6-2  
RoHS Directive

## EXTERNAL VIEW

### ■ TOP VIEW

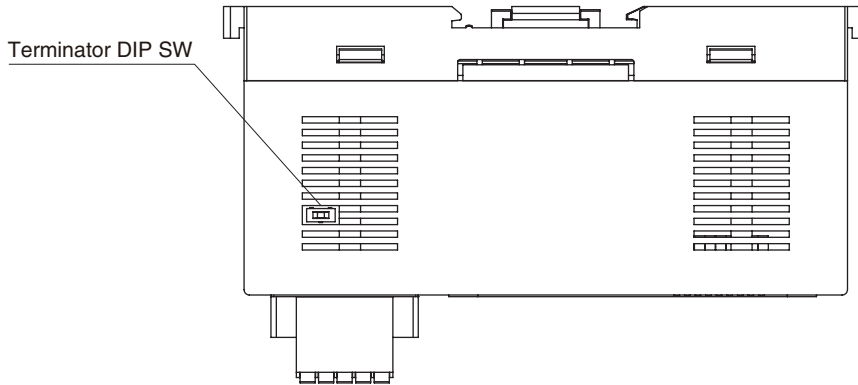

### ■ FRONT VIEW

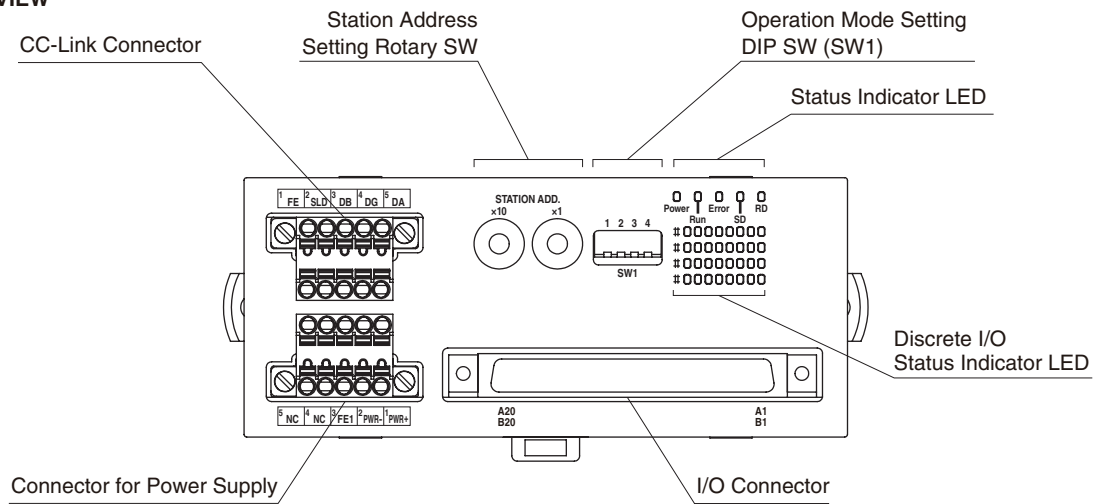

## CONNECTION DIAGRAMS

### ■ MASTER CONNECTION

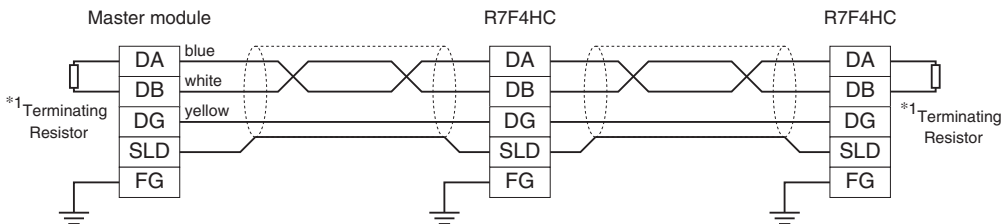

\*1. Turn on the terminator DIP switch to activate the internal terminating resistor.

## TERMINAL ASSIGNMENTS

### ■CC-Link, POWER SUPPLY ASSIGNMENT

Unit side connector: MC1,5/5-GF-3,5 (Phoenix Contact)  
 Cable side connector: TFMC1,5/5-STF-3,5 (Phoenix Contact)  
 Applicable wire size: 0.2 - 1.5mm<sup>2</sup>, stripped length 10mm  
 AI0,25-10YE 0.25mm<sup>2</sup> (Phoenix Contact)  
 A0,34-10TQ 0.34mm<sup>2</sup> (Phoenix Contact)  
 AI0,5-10WH 0.5mm<sup>2</sup> (Phoenix Contact)  
 AI0,75-10GY 0.75mm<sup>2</sup> (Phoenix Contact)  
 AI1-10 1.0mm<sup>2</sup> (Phoenix Contact)  
 AI1,5-10 1.5mm<sup>2</sup> (Phoenix Contact)

#### · CC-Link

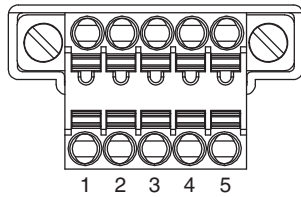

#### · POWER SUPPLY

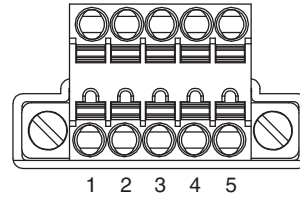

NO.	ID	FUNCTION
1	FE	Functional earth
2	SLD	Shield
3	DB	DB (white)
4	DG	DG (yellow)
5	DA	DA (blue)

NO.	ID	FUNCTION
1	PWR+	Power supply +
2	PWR-	Power supply -
3	FE1	Grounding
4	NC	Unused
5	NC	Unused

Note: The numbers marked on the connector have no relationship to the pin number of the unit.  
 Wire according to the instruction manual of the unit.

### ■ I/O, SENSOR EXC. ASSIGNMENT

Unit side connector: N365P040AU (OTAX) (FCN-365P040-AU (Fujitsu)...discontinued)  
 Cable side connector: N36(J040AU(OTAX) (FCN-36(J040-AU (Fujitsu)...discontinued)  
 (The cable connector is not included in the package. Specify wire size instead of ( )); refer to the specifications of the product)



PIN NO.	ID	FUNCTION	PIN NO.	ID	FUNCTION
A1	VS+	Exc. supply +	B1	VS+	Exc. supply +
A2	VS-	Exc. supply -	B2	VS-	Exc. supply -
A3	YF	Output 15	B3	Y7	Output 7
A4	YE	Output 14	B4	Y6	Output 6
A5	YD	Output 13	B5	Y5	Output 5
A6	YC	Output 12	B6	Y4	Output 4
A7	YB	Output 11	B7	Y3	Output 3
A8	YA	Output 10	B8	Y2	Output 2
A9	Y9	Output 9	B9	Y1	Output 1
A10	Y8	Output 8	B10	Y0	Output 0
A11	NC	Unused	B11	NC	Unused
A12	COM	Common	B12	COM	Common
A13	XF	Input 15	B13	X7	Input 7
A14	XE	Input 14	B14	X6	Input 6
A15	XD	Input 13	B15	X5	Input 5
A16	XC	Input 12	B16	X4	Input 4
A17	XB	Input 11	B17	X3	Input 3
A18	XA	Input 10	B18	X2	Input 2
A19	X9	Input 9	B19	X1	Input 1
A20	X8	Input 8	B20	X0	Input 0

## DATA ALLOCATION

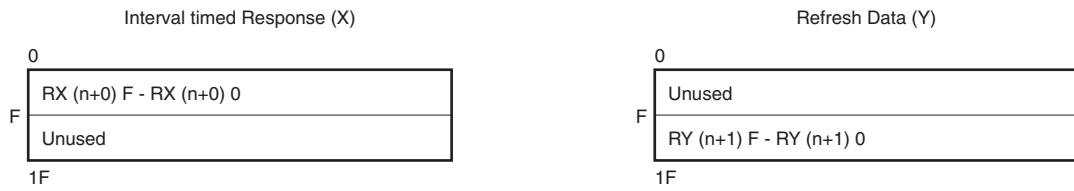

## I/O DATA DESCRIPTIONS

### DISCRETE I/O

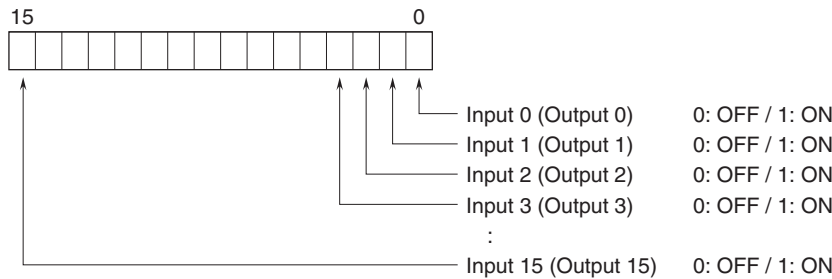

## EXTERNAL DIMENSIONS unit: mm [inch]

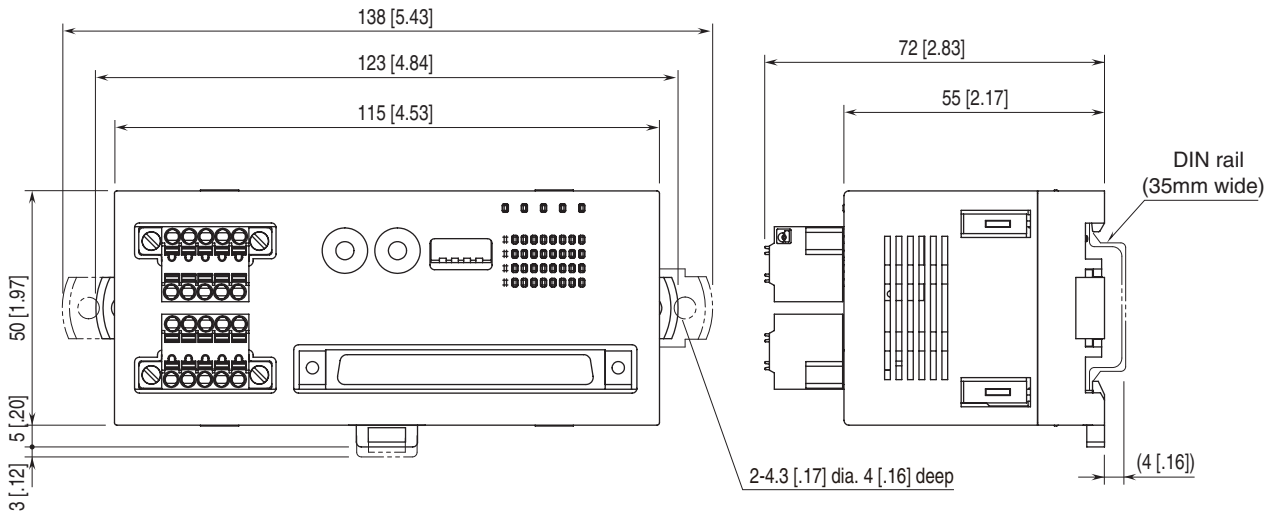

## MOUNTING REQUIREMENTS unit: mm [inch]

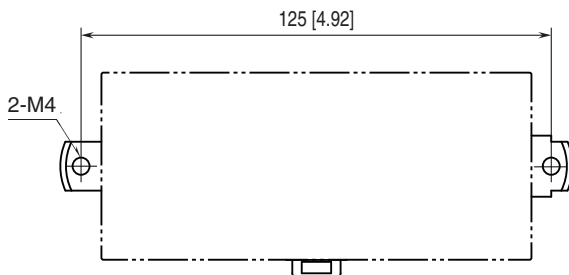

## SCHEMATIC CIRCUITRY & CONNECTION DIAGRAM

Note: In order to improve EMC performance, bond the FE1 terminal to ground.

Caution: FE1 terminal is NOT a protective conductor terminal.

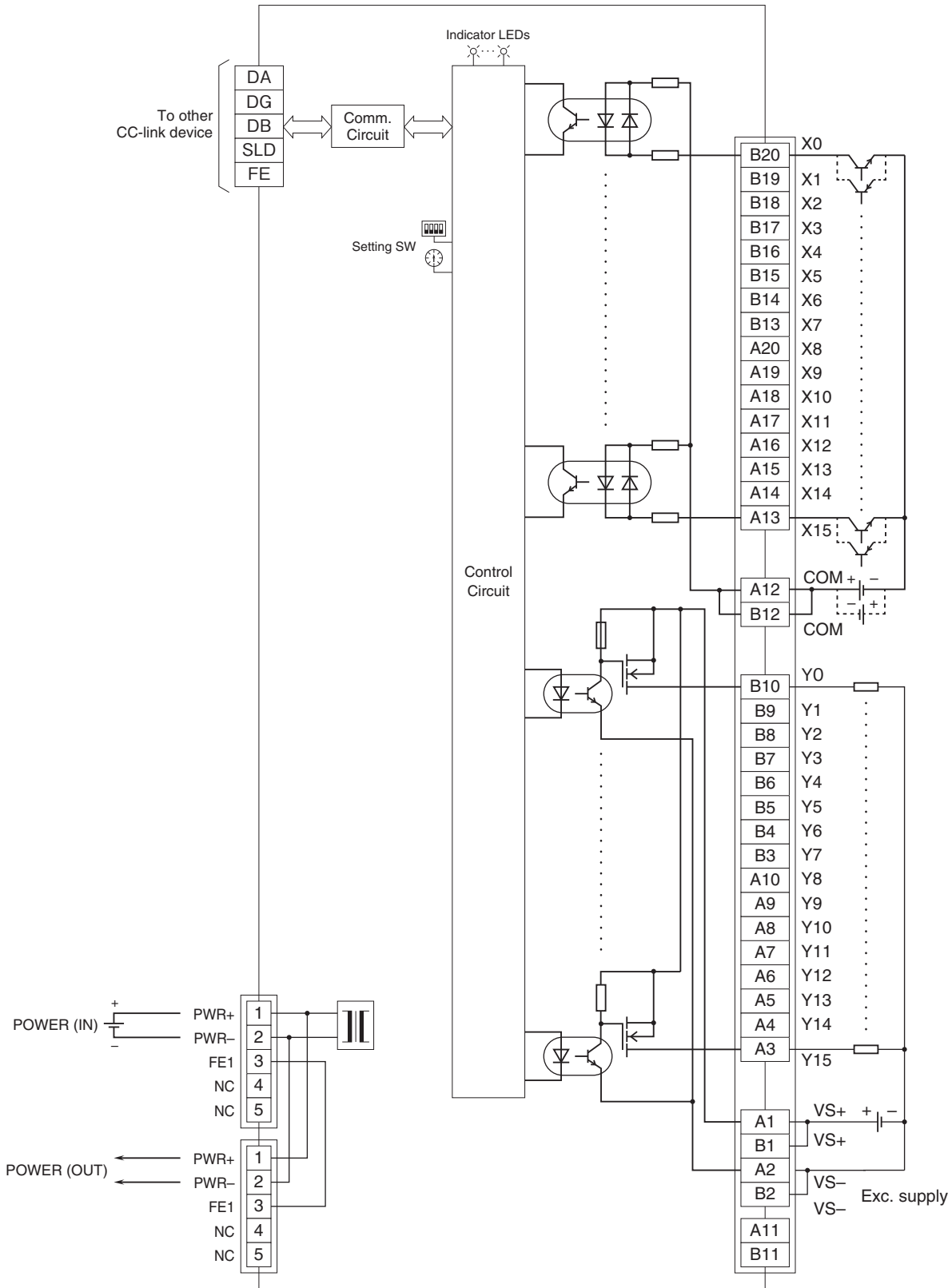



Specifications are subject to change without notice.