

Remote I/O R7 Series

FLEX NETWORK I/O MODULE

(High-speed DC voltage/current input, 4 points, non-isolated)

Functions & Features

- 4 points high-speed DC voltage/current input module for FLEX NETWORK
- Input range can be selected with the front DIP switches for all channels.
- Easy parameter setting of individual channels with the configurator software

FLEX NETWORK is registered trademark of Digital Electronics Corporation in Japan.

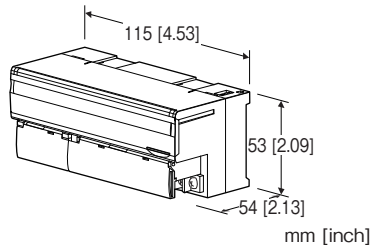

MODEL: R7FN-SVF4-R[1]

ORDERING INFORMATION

- Code number: R7FN-SVF4-R[1]
Specify a code from below for [1].
(e.g. R7FN-SVF4-R/Q)
- Specify the specification for option code /Q
(e.g. /C01/SET)

I/O TYPE

SVF4: DC voltage /current input high-speed, 4 points
(non-isolated) (10 V/20 mA)

POWER INPUT

DC Power
R: 24 V DC
(Operational voltage range 24 V \pm 10 %, ripple 10 %p-p max.)

[1] OPTIONS

blank: none
/Q: Options other than the above (specify the specification)

SPECIFICATIONS OF OPTION: Q (multiple selections)

COATING (For the detail, refer to our web site.)

/C01: Silicone coating

/C02: Polyurethane coating

/C03: Rubber coating

EX-FACTORY SETTING

/SET: Preset according to the Ordering Information Sheet
(No. ESU-7808-SVF4)

RELATED PRODUCTS

- PC configurator software (model: R7CON)

The configurator software is downloadable at our web site. A dedicated cable is required to connect the module to the PC. Please refer to the internet software download site or the users manual for the PC configurator for applicable cable types.

- Screen editor software (model: GP-Pro EX)

Screen editor software GP-Pro EX (Ver.2.70 or higher) is available.

For versions between 2.60 and 2.70, the driver must be installed. The driver is downloadable at Digital Electronics Corporation's web site. <http://www.proface.co.jp/>

GENERAL SPECIFICATIONS

Connection: M3 separable screw terminal (torque 0.5 N·m)

Solderless terminal: Refer to the drawing at the end of the section.

- **Communication cable**

Recommended manufacture: Japan Solderless Terminal MFG.Co.Ltd

Applicable wire size: 0.2 to 0.5 mm² (AWG 26 to 22)

- **Others**

Recommended manufacture: Japan solderless terminal MFG.Co.Ltd, Nichifu Co.,Ltd

Applicable wire size: 0.25 to 1.65 mm² (AWG 22 to 16)

Screw terminal: Nickel-plated steel

Housing material: Flame-resistant resin (gray)

Isolation: Input to FLEX NETWORK to power to FG

Zero adjustments: Configurable via R7CON

Span adjustments: Configurable via R7CON

Input range: Selectable with the DIP SW on the front of the unit or configurable via R7CON

Conversion rate: Configurable via R7CON

Number of times of averaging: No averaging (*), 2 samples, 4 samples, 8 samples
Configurable via R7CON

(*): Factory default setting

Status indicator LED: PWR, RUN

(Refer to the instruction manual)

■ Recommended solderless terminal

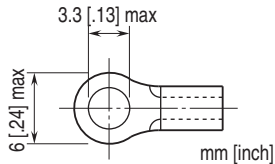

PERFORMANCE

Conversion rate / Conversion accuracy: 2 msec. / $\pm 0.1\%$

Data range: 0 - 10000 of the input range

Temp. coefficient: $\pm 0.015\%/^{\circ}\text{C}$ ($\pm 0.008\%/^{\circ}\text{F}$)

Response time: Conversion rate $\times 2$ + scan time (0 - 90 %)

Scan time depends on the Final Satellite (FS) value of Center IC (master) configuration and transfer rate (TBPS). It is calculated with the following formula. Scan time = $354 \times \text{FS} \times \text{TBPS}$ (seconds)

E.g) When "Final satellite value = 63, transfer rate = 12 Mbps, scan time is = $354 \times 63 \times 1/12 \text{ M} = 1.859 \text{ msec.}$

Insulation resistance: $\geq 100 \text{ M}\Omega$ with 500 V DC

Dielectric strength: 1500 V AC @ 1 minute (input to FLEX NETWORK to power to FG)

FLEX NETWORK COMMUNICATION

Communication configuration: 1: N

Connection method: Multi-drop Connection

Communication method: Cyclic Time Division, half-duplex

Communication I/F: Differential, pulse transfer isolation

Error Check: Format, bit, CRC-12 verification

Max. Number of Nodes: 63 (1008 I/O points)

Required node: 4

Network cable: Pro-face's following cable

FN-CABLE2010-31-MS (10 m)

FN-CABLE2050-31-MS (50 m)

FN-CABLE2200-31-MS (200 m)

Transmission distance: 12 Mbps: 100 meters (328 ft)(*)

6 Mbps: 200 meters (656 ft)

(*) Factory default setting

Station address: Rotary switch

(Refer to the instruction manual)

Terminating resistor: Built-in

INPUT SPECIFICATIONS

■ DC Current

Input resistor: 50 Ω

Input range: -20 to +20 mA DC, 0 to 20 mA DC,

4 to 20 mA DC

■ Narrow span voltage

Input resistance: $\geq 100 \text{ k}\Omega$

Input range: -1 to +1 V DC, 0 to 1 V DC, -0.5 to +0.5 V DC

■ Wide span voltage

Input resistance: $\geq 1 \text{ M}\Omega$

Input range: -10 to +10 V DC (*), -5 to +5 V DC,

0 to 10 V DC, 0 to 5 V DC, 1 to 5 V DC

(*) Factory default setting

INSTALLATION

Current consumption

•DC: Approx. 90 mA

Operating temperature: -10 to +55 $^{\circ}\text{C}$ (14 to 131 $^{\circ}\text{F}$)

Storage temperature: -20 to +65 $^{\circ}\text{C}$ (-4 to +149 $^{\circ}\text{F}$)

Operating humidity: 30 to 90 %RH (non-condensing)

Atmosphere: No corrosive gas or heavy dust

Mounting: DIN rail (35 mm rail)

Weight: 200 g (0.44 lb)

EXTERNAL VIEW

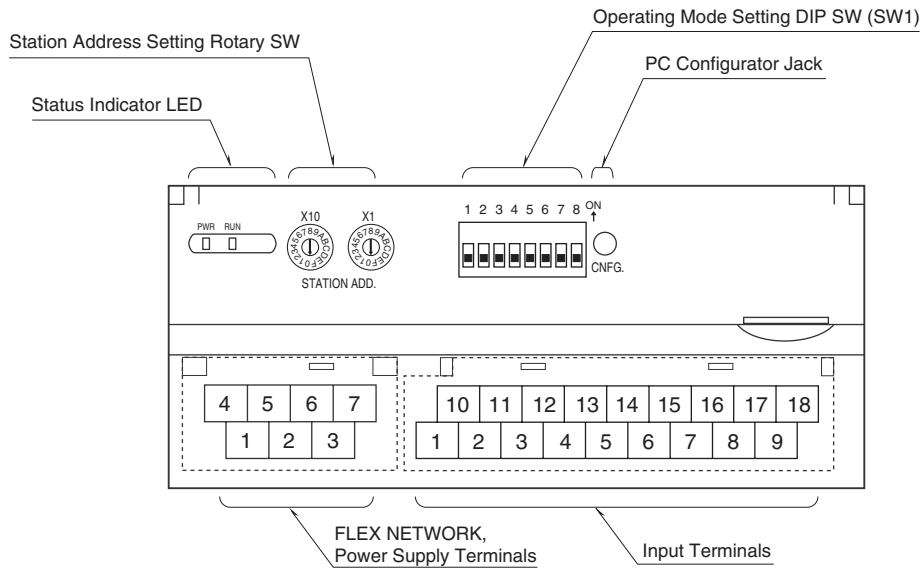

CONNECTION DIAGRAMS

■ MASTER CONNECTION

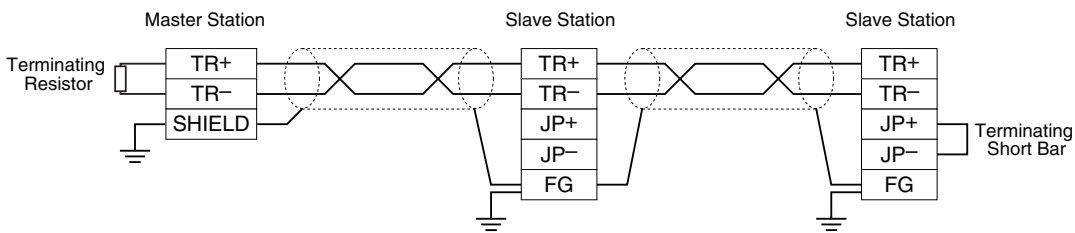

Note: Be sure to use the terminator(s) located at both ends of the modules.

TERMINAL ASSIGNMENTS

■ INPUT TERMINAL ASSIGNMENT

10	11	12	13	14	15	16	17	18
VL0	I0	VL1	I1	NC	VL2	I2	VL3	I3
1	2	3	4	5	6	7	8	9
VH0	COM0	VH1	COM1	NC	VH2	COM2	VH3	COM3

NO.	ID	FUNCTION	NO.	ID	FUNCTION
1	VH0	Wide span volt. 0	10	VL0	Narrow span volt. 0
2	COM0	Common 0	11	I0	Current range 0
3	VH1	Wide span volt. 1	12	VL1	Narrow span volt. 1
4	COM1	Common 1	13	I1	Current range 1
5	NC	No connection	14	NC	No connection
6	VH2	Wide span volt. 2	15	VL2	Narrow span volt. 2
7	COM2	Common 2	16	I2	Current range 2
8	VH3	Wide span volt. 3	17	VL3	Narrow span volt. 3
9	COM3	Common 3	18	I3	Current range 3

■ NETWORK, POWER SUPPLY TERMINAL ASSIGNMENT

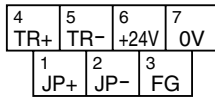

NO.	ID	FUNCTION, NOTES
1	JP+	Terminating resistor
2	JP-	Terminating resistor
3	FG	FG
4	TR+	Network
5	TR-	Network
6	+24V	Power input (24V DC)
7	0V	Power input (0V)

DATA CONVERSION

■ INPUT RANGE AND DATA CONVERSION (FACTORY DEFAULT SETTING)

Analog input data is converted into digital representations of 0 – 100% proportional to each scaled range.

The converted % values are multiplied by 100 and expressed in 16 bits.

Overrange input is possible from -15% to +115% of the nominal range.

When the signal exceeds the limit, the data is fixed at -15% or +115%.

• Input Range 0 – 5V DC

Input Value	Input %	Converted Data, Decimal	Converted Data, Hex
≤ -0.75V	-15%	-1500	FA24
0V	0%	0	0
5V	100%	10000	2710
≥ 5.75V	115%	11500	2CEC

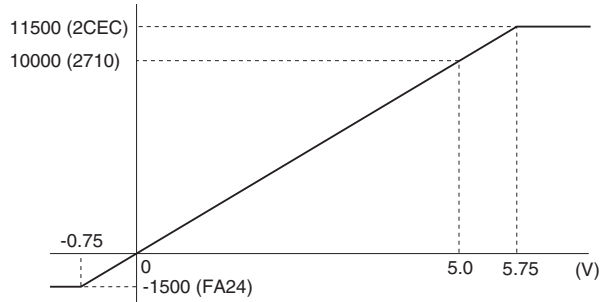

I/O DATA DESCRIPTIONS

■ ANALOG INPUT

• Di

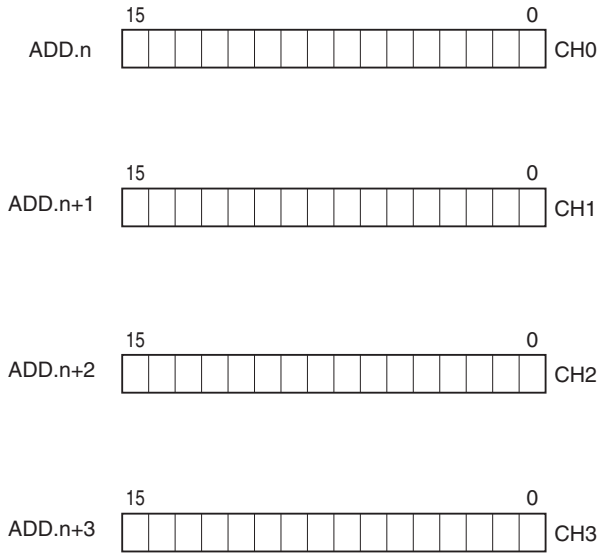

• Do

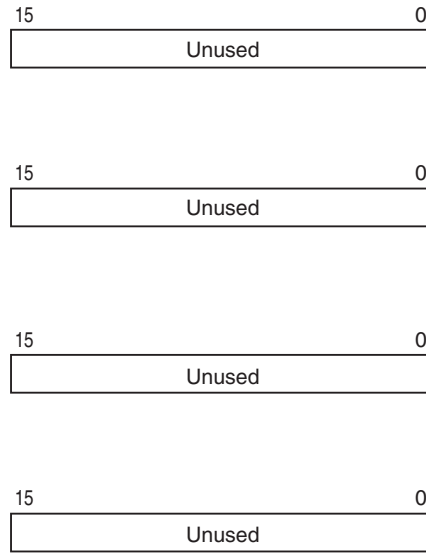

The data is 16-bit binary.
Negative value is represented in 2's complements.

EXTERNAL DIMENSIONS & TERMINAL ASSIGNMENTS unit: mm [inch]

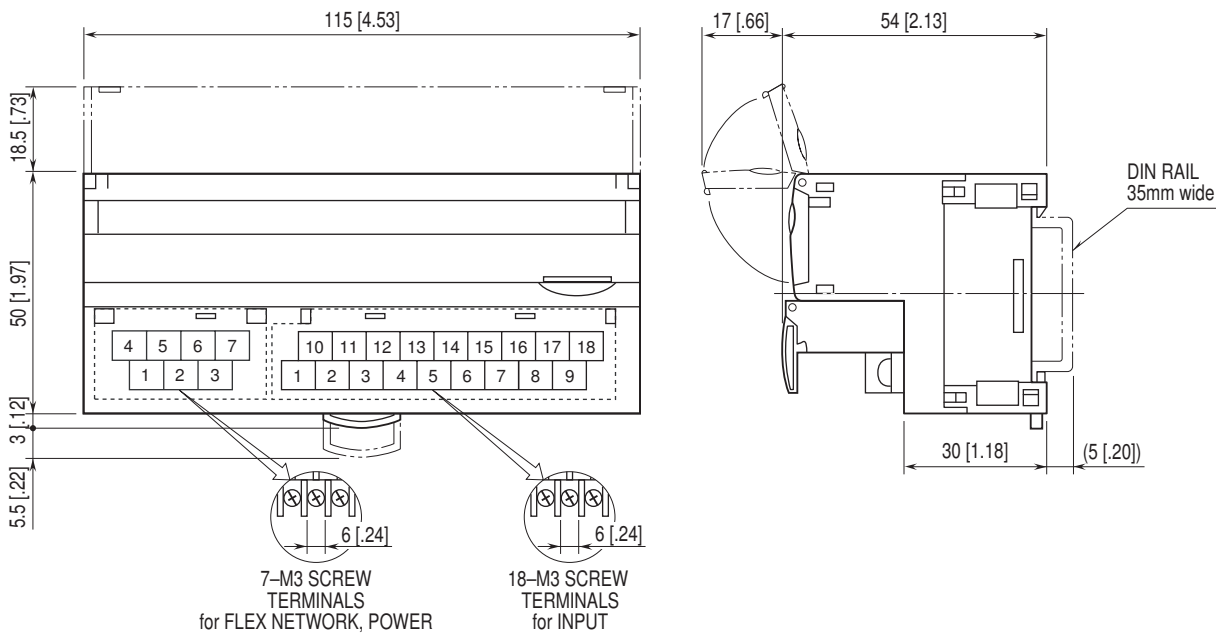

SCHEMATIC CIRCUITRY & CONNECTION DIAGRAM

Caution: FG terminal is NOT a protective conductor terminal.

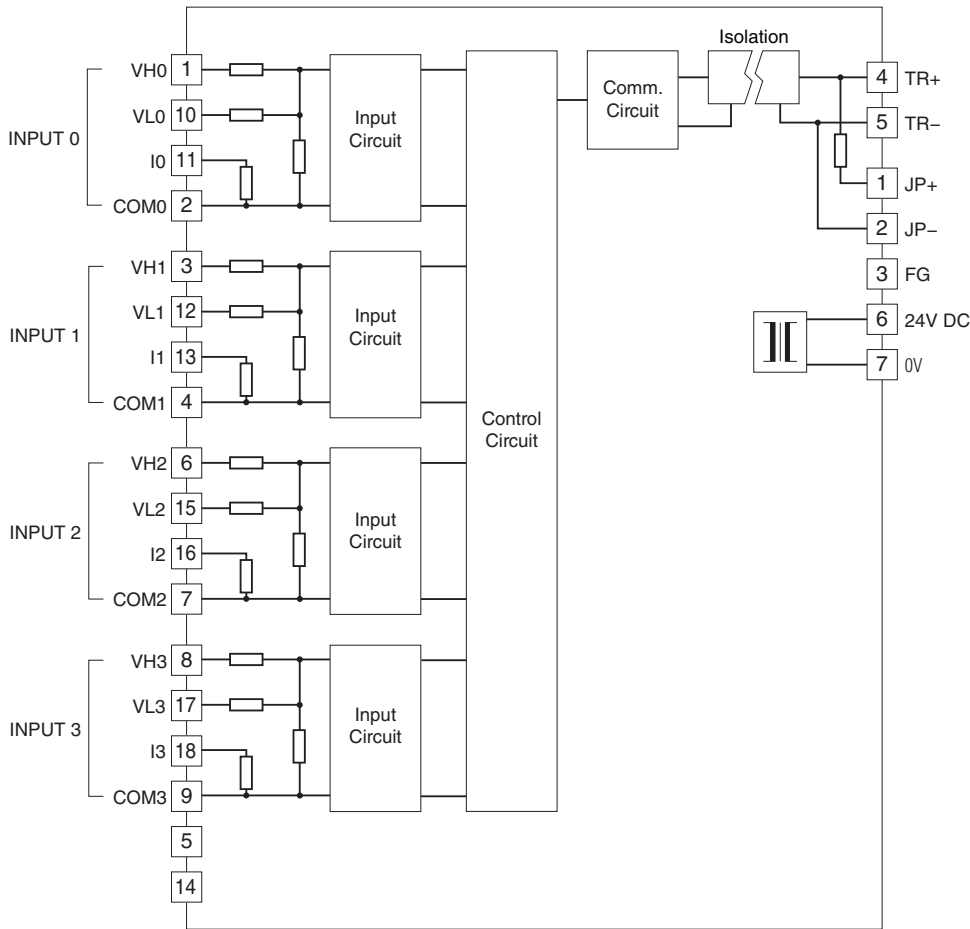

Input Connection Examples

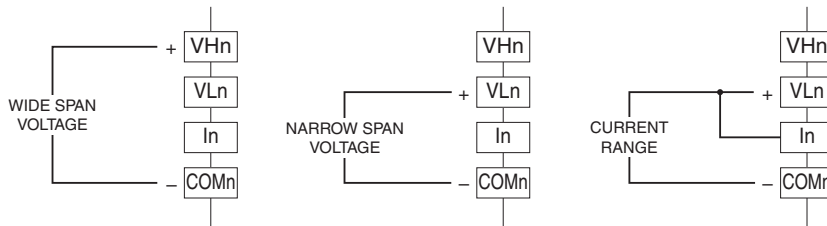

Be sure to close across VLn and In terminals for a current input.



Specifications are subject to change without notice.