

MODEL: R7G4FML3-6-DA16

Remote I/O R7G4F Series

MECHATROLINK I/O MODULE

(NPN/PNP discrete input, 16 points, screw terminal block, MECHATROLINK-III use)

Functions & Features

16 points NPN/PNP discrete input module for MECHATROLINK-III

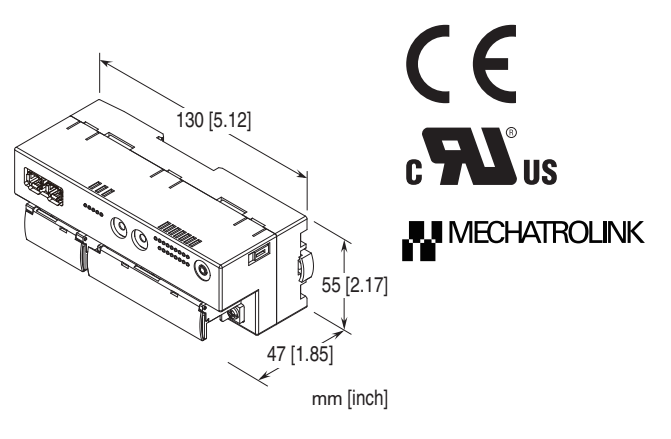

MODEL: R7G4FML3-6-DA16-R[1]

ORDERING INFORMATION

- Code number: R7G4FML3-6-DA16-R[1]
Specify a code from below for [1].
(e.g. R7G4FML3-6-DA16-R/UL/Q)
- Specify the specification for option code /Q
(e.g. /C01)

TERMINAL BLOCK

- 6: Screw terminal block for power supply
Connector for MECHATROLINK-III
Screw terminal block for I/O

TYPE

DA16: NPN/PNP discrete input, 16 points

POWER INPUT

DC power
R: 24 V DC
(Operational voltage range: $\pm 10\%$; ripple 10 %p-p max.)

[1] OPTIONS (multiple selections)

Standards & Approvals
blank: CE marking
/UL: UL approval, CE marking
Other Options

blank: none

/Q: Option other than the above (specify the specification)

SPECIFICATIONS OF OPTION: Q

COATING (For the detail, refer to our web site.)

/C01: Silicone coating

/C02: Polyurethane coating

/C03: Rubber coating (UL not available)

GENERAL SPECIFICATIONS

Connection

MECHATROLINK-III: MECHATROLINK-III connector

Power input, input: M3 separable screw terminal (torque 0.5 N·m)

Solderless terminal: Refer to the drawing at the end of the section.

Recommended manufacturer: Japan Solderless Terminal MFG.Co.Ltd, Nichifu Co.,Ltd

Applicable wire size: 0.25 to 1.65 mm² (AWG 22 to 16)

Screw terminal: Nickel-plated steel

Housing material: Flame-resistant resin (gray)

Isolation: Input to MECHATROLINK or FE to power

Status indicator LEDs: PWR, ERR, CON, LNK1, LNK2 (5 LEDs) indicate the module's operating conditions. (Refer to the instruction manual)

Discrete input status indicator LED: Green LED turns on with input ON

Read rate: 1 / 5 / 10(*) / 20 / 50 / 70 / 100 / 200 msec.

selectable with R7CFG

(*) factory default setting

■ Recommended solderless terminal

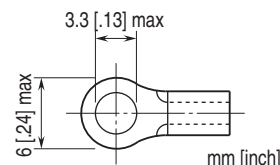

MECHATROLINK-III COMMUNICATION

Baud rate: 100 Mbps

Transmission distance: 6300 m max.

Distance between stations: 100 m max.

Transmission media: MECHATROLINK cable (Model JEMC-W6013-x-E, Yaskawa Controls Co., Ltd.)

Connector: TYCO AMP Industrial mini I/O connector

Max. number of slaves: 62

(The maximum number of slaves might change depending on the master unit. Refer to the manual of the master unit)

Transmission cycle: 125 μ sec., 250 μ sec., 500 μ sec., 1 - 64 msec. (with 1 msec. increments)

Communication cycle: 125 μ sec. through 64 msec.

Applicable profile: Standard I/O profile (cyclic communication)

Event-driven communication acquiring ID profile (event-driven communication)

Transmission bytes: 16 bytes

Station address: 03H through EFH (set with rotary switches)

Cyclic communication: Available

Event-driven communication: Available

Slave monitoring: None

INPUT SPECIFICATIONS

Common: Positive or negative common (NPN/PNP) per 16 points

Maximum inputs applicable at once: No limit (at 24 V DC)

Rated input voltage: 24 V DC $\pm 10\%$; ripple 5 %p-p max.

ON voltage / current: ≥ 15 V DC (input - COM) / ≥ 3.5 mA

OFF voltage / current: ≤ 5 V DC (input - COM) / ≤ 1 mA

Input current: ≤ 5.5 mA per point at 24 V DC

Input resistance: Approx. 4.4 k Ω

ON delay: ≤ 0.2 msec.

OFF delay: ≤ 0.5 msec.

INSTALLATION

Power consumption: Approx. 75 mA

Operating temperature: -10 to +55°C (14 to 131°F)

Storage temperature: -20 to +65°C (-4 to +149°F)

Operating humidity: 30 to 90 %RH (non-condensing)

Atmosphere: No corrosive gas or heavy dust

Mounting: Surface or DIN rail (35 mm rail)

Weight: 190 g (0.42 lb)

PERFORMANCE

Insulation resistance: ≥ 100 M Ω with 500 V DC

Dielectric strength: 1500 V AC @ 1 minute (input to MECHATROLINK or FE to power)

STANDARDS & APPROVALS

EU conformity:

EMC Directive

EMI EN 61000-6-4

EMS EN 61000-6-2

RoHS Directive

Safety approval:

UL/C-UL general safety requirements

(UL 61010-1, CAN/CSA-C22.2 No.61010-1-12)

(UL 61010-2-201, CAN/CSA-C22.2 No.61010-2-201)

EXTERNAL VIEW

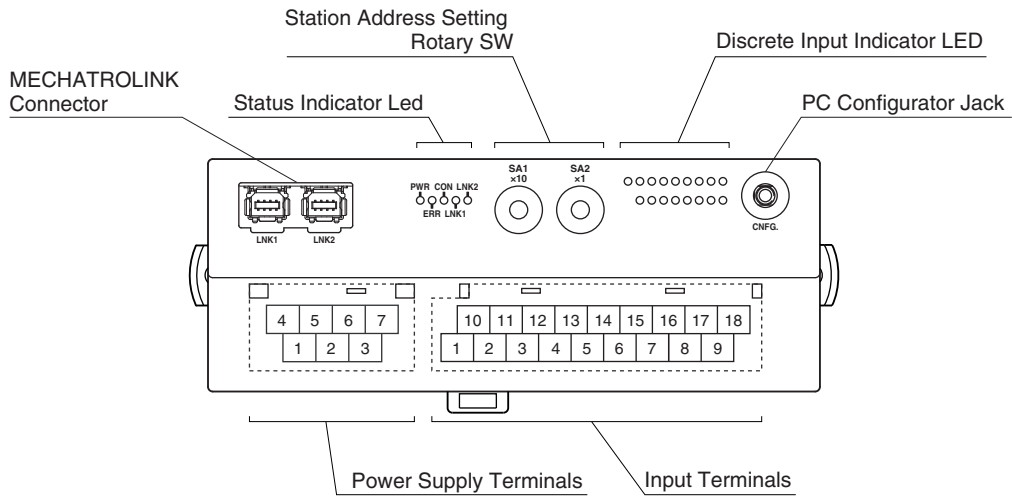

TERMINAL ASSIGNMENTS

INPUT TERMINAL ASSIGNMENT

10	11	12	13	14	15	16	17	18
COM	X1	X3	X5	X7	X9	X11	X13	X15
1	2	3	4	5	6	7	8	9
COM	X0	X2	X4	X6	X8	X10	X12	X14

NO.	ID	FUNCTION	NO.	ID	FUNCTION
1	COM	Common	10	COM	Common
2	X0	Input 0	11	X1	Input 1
3	X2	Input 2	12	X3	Input 3
4	X4	Input 4	13	X5	Input 5
5	X6	Input 6	14	X7	Input 7
6	X8	Input 8	15	X9	Input 9
7	X10	Input 10	16	X11	Input 11
8	X12	Input 12	17	X13	Input 13
9	X14	Input 14	18	X15	Input 15

POWER SUPPLY TERMINAL ASSIGNMENT

4	5	6	7
NC	NC	+24V	0V
1	2	3	
NC	NC	FE	

- 1. NC -
- 2. NC -
- 3. FE Functional earth
- 4. NC -
- 5. NC -
- 6. +24V Power supply (24V DC)
- 7. 0V Power supply (0V)

MECHATROLINK RELATED COMMANDS

Commands available with this unit are the following.

PROFILE	COMMAND	CODE	FUNCTION
Common command	NOP	00H	No operation command
	ID_RD	03H	Read ID command
	CONFIG	04H	Setup device command
	ALM_RD	05H	Read alarm or warning command
	ALM_CLR	06H	Clear alarm or warning command
	CONNECT	0EH	Establish connection command
	DISCONNECT	0FH	Release connection command
Standard I/O profile	DATA_RWA	20H	Transmit I/O data

RESPONSE TIME

Response time of discrete input module is the time till when the unit starts sending to a transmission line when a signal is applied to the input module.

T_{COM} : MECHATROLINK-III transmission cycle configured by a host device.

MECHATROLINK-III transmission cycle varies depends on system and configuration.

T_{INP} : Response time of input module $\leq T_a$ Delay of input circuit (ON delay time or OFF delay time) +

T_b Read rate setting time +

T_c Internal processing delay time (2 cycle of MECHATROLINK-III transmission cycle)

E.g. Read rate of 1 msec., MECHATROLINK-III transmission cycle of 0.25 msec.

Response time of input module (T_{INP}): Delay of input circuit (0.2 msec.) + Read rate setting time (1 msec.) + Internal processing delay time (0.25 msec.) $\times 2 = 1.7$ [msec.]

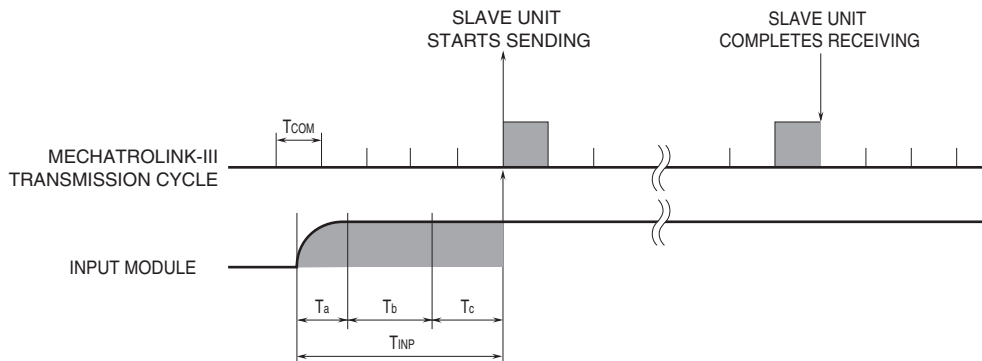

I/O DATA DESCRIPTIONS

■ DISCRETE INPUT

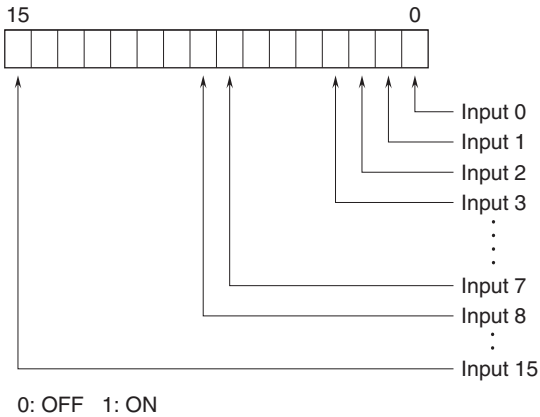

EXTERNAL DIMENSIONS & TERMINAL ASSIGNMENTS unit: mm [inch]

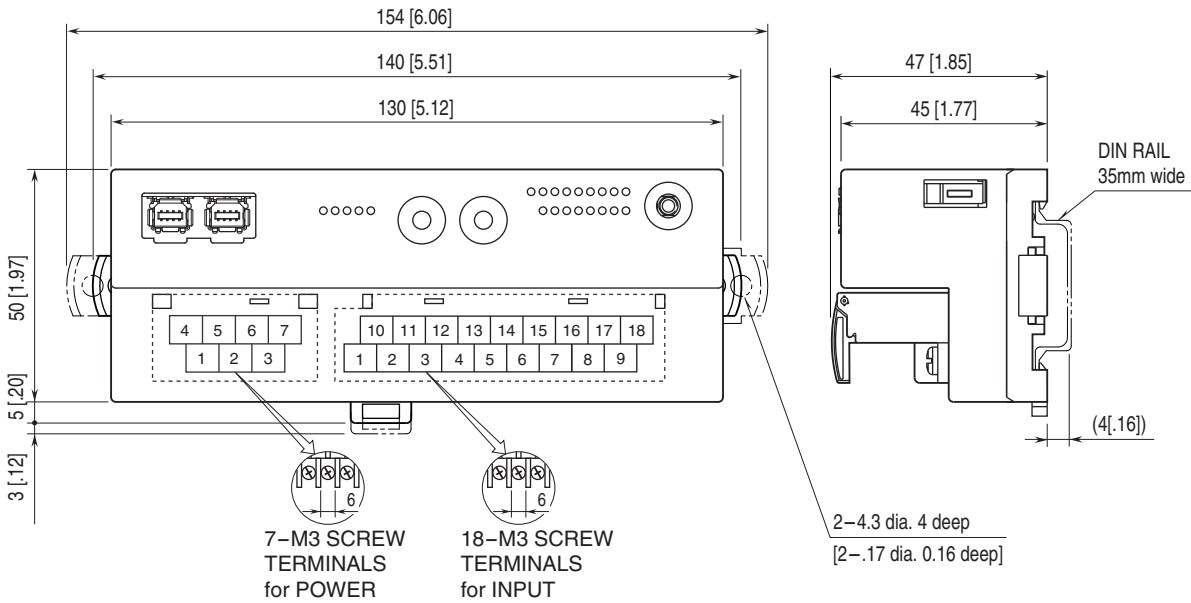

MOUNTING REQUIREMENTS unit: mm [inch]

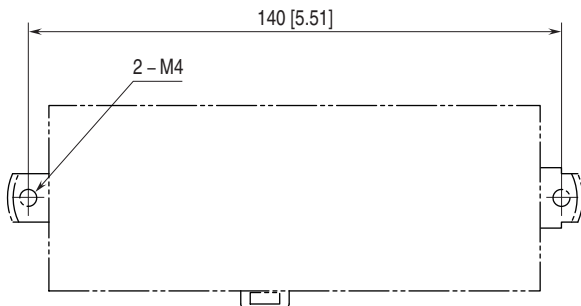

SCHEMATIC CIRCUITRY & CONNECTION DIAGRAM

Note: In order to improve EMC performance, bond the FE terminal to ground.

Caution: FE terminal is NOT a protective conductor terminal.

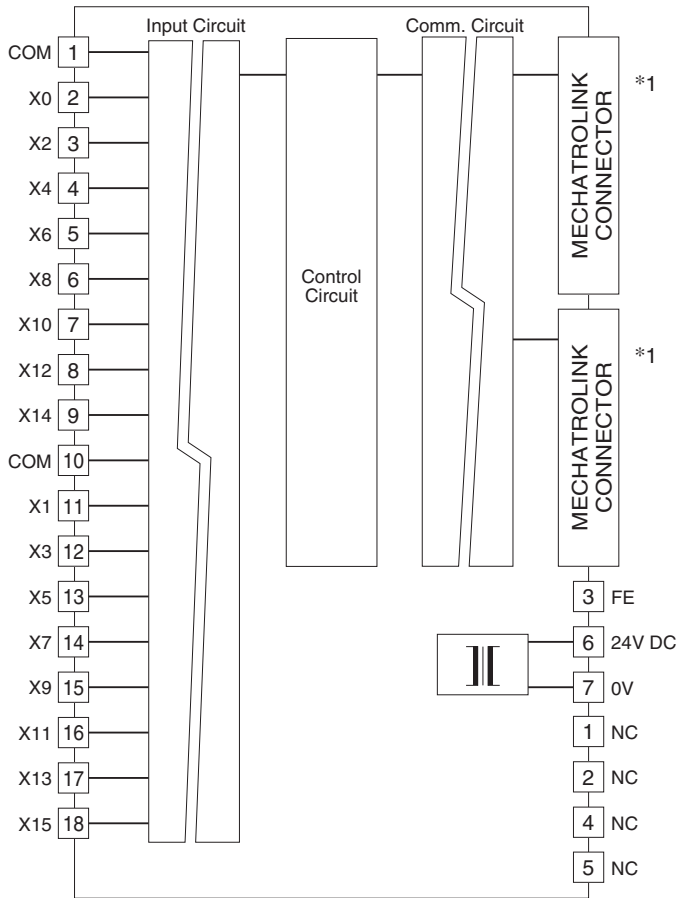

*1. The network cable can be connected to either one.

Input Circuit

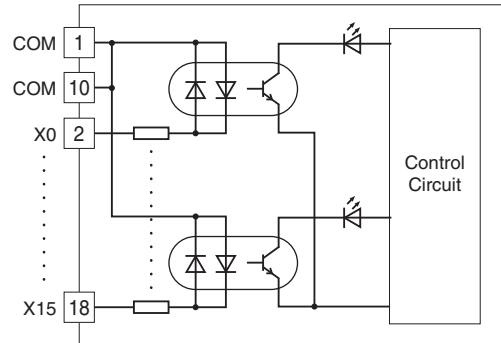

Input Connection Examples

PNP Connection

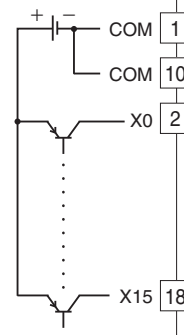

NPN Connection

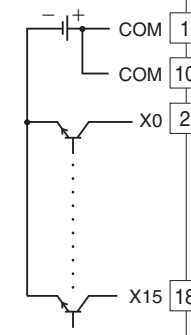

Specifications are subject to change without notice.