

Remote I/O R7G4H Series

MECHATROLINK I/O MODULE

(high-speed DC voltage/current input, 4 points, isolated, screw terminal block, MECHATROLINK- I/- II use)

Functions & Features

- 4 points high-speed DC voltage/current input for MECHATROLINK- I/- II
- Easy parameter setting of individual channels with the configurator software

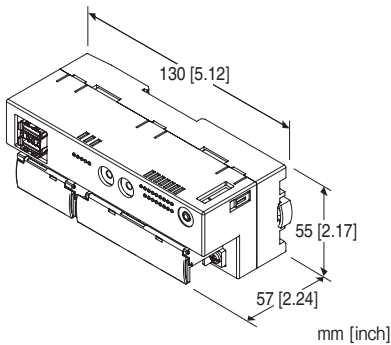

MECHATROLINK

MODEL: R7G4HML-6-SVF4-R[1]

ORDERING INFORMATION

- Code number: R7G4HML-6-SVF4-R[1]
Specify a code from below for [1].
(e.g. R7G4HML-6-SVF4-R/Q)
- Specify the specification for option code /Q
(e.g. /C01/SET)

TERMINAL BLOCK

- 6: Screw terminal block for power supply
Connector for MECHATROLINK-I/-II
Screw terminal block for I/O

I/O TYPE

SVF4: DC voltage /current input (10 V/20 mA), high-speed, 4 points

POWER INPUT

DC Power

R: 24 V DC

(Operational voltage range 24 V \pm 10 %, ripple 10 %p-p max.)

[1] OPTIONS

blank: none

/Q: With options (specify the specification)

SPECIFICATIONS OF OPTION: Q (multiple selections)

COATING (For the detail, refer to our web site.)

/C01: Silicone coating

/C02: Polyurethane coating

/C03: Rubber coating

EX-FACTORY SETTING

/SET: Preset according to the Ordering Information Sheet (No. ESU-7775-B)

RELATED PRODUCTS

- PC Configurator cable (model: MCN-CON or COP-US)
- PC configurator software (model: R7CFG)

Downloadable at our web site.

GENERAL SPECIFICATIONS

Connection

MECHATROLINK: MECHATROLINK-I/-II connector

Power input, input: M3 separable screw terminal (torque 0.5 N·m)

Solderless terminal: Refer to the drawing at the end of the section.

Recommended manufacturer: Japan Solderless Terminal MFG.Co.Ltd, Nichifu Co.,Ltd

Applicable wire size: 0.25 to 1.65 mm² (AWG 22 to 16)

Screw terminal: Nickel-plated steel

Housing material: Flame-resistant resin (gray)

Isolation: Input 0 to input 1 to input 2 to input 3 to MECHATROLINK or FE to power

Zero adjustments: Configurable via R7CFG

Span adjustments: Configurable via R7CFG

Input range: Selectable with the DIP SW on the top of the unit or configurable via R7CFG

Number of times of averaging: Configurable via R7CFG

Status indicator LEDs: PWR, RUN, ERR, SD, RD (Refer to the instruction manual)

■ Recommended solderless terminal

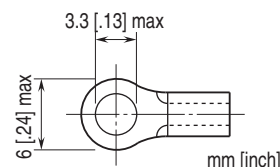

MECHATROLINK COMMUNICATION

MECHATROLINK mode: Set with DIP switches

(MECHATROLINK-I or -II, data length; Factory setting:

MECHATROLINK-II; data length (17 bytes)

MODEL: R7G4HML-6-SVF4

(Refer to the instruction manual)

Station address: 60H - 7FH

(Function selected with Rotary SW. Factory setting: 61H).

(Refer to the instruction manual)

■ MECHATROLINK-I

Baud rate: 4 Mbps

Transmission distance: 50 m max.

Distance between stations: 30 cm min.

Transmission media: MECHATROLINK cable (Model JEPMC-W6003-x-E, Yaskawa Controls Co., Ltd.)

Max. number of slaves: 15

(The maximum number of slaves might change depending on the master unit. Refer to the manual of the master unit)

Transmission cycle: 2 msec. (fixed)

Data length: 17 bytes

■ MECHATROLINK-II

Baud rate: 10 Mbps

Transmission distance: 50 m max.

Distance between stations: 50 cm min.

Transmission media: MECHATROLINK cable (Model JEPMC-W6003-x-E, Yaskawa Controls Co., Ltd.)

Max. number of slaves: 30

(The maximum number of slaves might change depending on the master unit. Refer to the manual of the master unit)

Transmission cycle: 0.5 msec., 1 msec., 1.5 msec., 2 msec., 4 msec., 8 msec.

Data length: 17 bytes / 32 bytes selectable (Must choose identical data size for all stations on one network)

INPUT SPECIFICATIONS

■ Current range

Input resistance: 50 Ω

Input range: -20 - +20 mA DC, 0 - 20 mA DC, 4 - 20 mA DC

■ Narrow span voltage

Input resistance: ≥100 kΩ

Input range: -1 - +1 V DC, 0 - 1 V DC, -0.5 - +0.5 V DC

■ Wide span voltage

Input resistance: ≥ 1 MΩ

Input range: -10 - +10 V DC, -5 - +5 V DC, 0 - 10 V DC, 0 - 5 V DC, 1 - 5 V DC

INSTALLATION

Current consumption

•DC: Approx 70 mA

Operating temperature: 0 to 55°C (32 to 131°F)

Storage temperature: -20 to +65°C (-4 to +149°F)

Operating humidity: 30 to 90 %RH (non-condensing)

Atmosphere: No corrosive gas or heavy dust

Mounting: Surface or DIN rail (35 mm rail)

Weight: 220 g (0.49 lb)

PERFORMANCE

Conversion accuracy: ±0.1 %

Conversion rate: 1 msec. / 4 CH

Data range: 0 - 10000 of the input range

Temp. coefficient: ±0.015 %/°C (±0.008 %/°F)

Input delay time: ≤ 1 msec. (0 - 90 %)

Insulation resistance: ≥ 100 MΩ with 500 V DC

Isolation: 1500 V AC @ 1 minute

(input 0 to input 1 to input 2 to input 3 MECHATROLINK or FE to power)

STANDARDS & APPROVALS

EU conformity:

EMC Directive

EMI EN 61000-6-4

EMS EN 61000-6-2

RoHS Directive

PC CONFIGURATOR

The following parameters can be set with using PC Configurator Software (model: R7CFG)

Refer to the users manual for the R7CFG for detailed operation of the software program.

■ SETTINGS FOR INDIVIDUAL CHANNELS

PARAMETER	SETTING RANGE	DEFAULT SETTING
Validating/ Invalidating	Valid Invalid	Valid
Input range	-10 - +10 V DC -5 - +5 V DC -1 - +1 V DC 0 - 10 V DC 0 - 5 V DC 1 - 5 V DC 0 - 1 V DC -0.5 - +0.5 V DC -20 - +20 mA DC 0 - 20 mA DC 4 - 20 mA DC	-10 - +10 V DC
Bias	-320.00 - +320.00 (%)	0.00 (%)
Gain	-3.2000 - +3.2000	1.0000
Zero scale	-32 000 - +32 000	0
Full scale	-32 000 - +32 000	10 000

■ SETTINGS FOR ALL CHANNELS

PARAMETER	SETTING RANGE	DEFAULT SETTING
Number of times of averaging	1, 2, 4, 8, 16, 32, 64, 128, 256	1

EXTERNAL VIEW

■ TOP VIEW

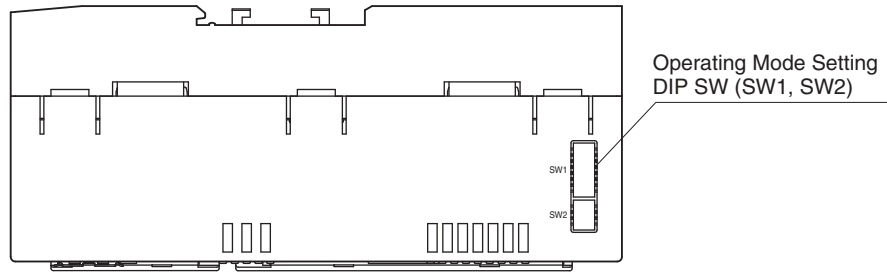

■ FRONT VIEW

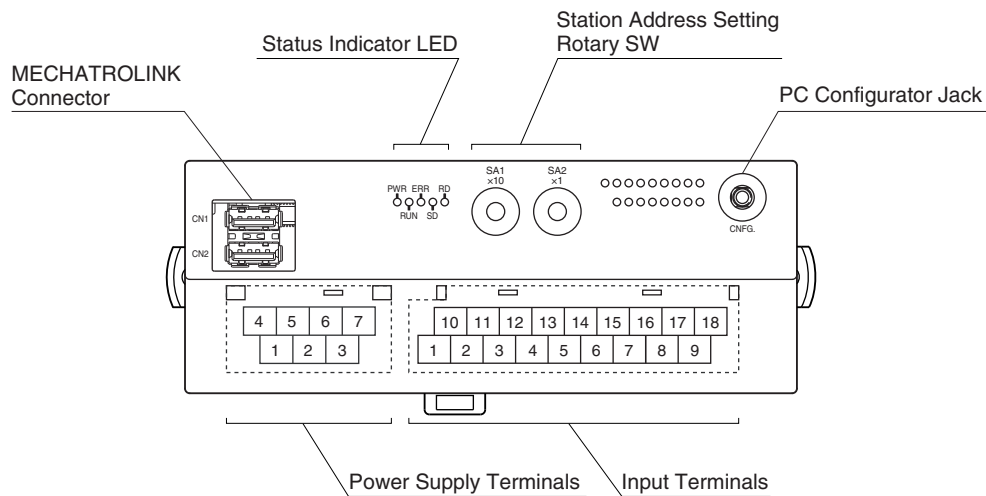

TERMINAL ASSIGNMENTS

■ INPUT TERMINAL ASSIGNMENT

10	11	12	13	14	15	16	17	18
VL0	I0	VL1	I1	NC	VL2	I2	VL3	I3
1	2	3	4	5	6	7	8	9
VH0	COM0	VH1	COM1	NC	VH2	COM2	VH3	COM3

NO.	ID	FUNCTION	NO.	ID	FUNCTION
1	VH0	Wide span volt. 0	10	VL0	Narrow span volt. 0
2	COM0	Common 0	11	I0	Current range 0
3	VH1	Wide span volt. 1	12	VL1	Narrow span volt. 1
4	COM1	Common 1	13	I1	Current range 1
5	NC	No connection	14	NC	No connection
6	VH2	Wide span volt. 2	15	VL2	Narrow span volt. 2
7	COM2	Common 2	16	I2	Current range 2
8	VH3	Wide span volt. 3	17	VL3	Narrow span volt. 3
9	COM3	Common 3	18	I3	Current range 3

POWER SUPPLY TERMINAL ASSIGNMENT

4	5	6	7
NC	NC	+24V	0V
1	2	3	
NC	NC	FE	

- 1. NC -
- 2. NC -
- 3. FE Functional earth
- 4. NC -
- 5. NC -
- 6. +24V Power supply (24V DC)
- 7. 0V Power supply (0V)

MECHATROLINK CONNECTION

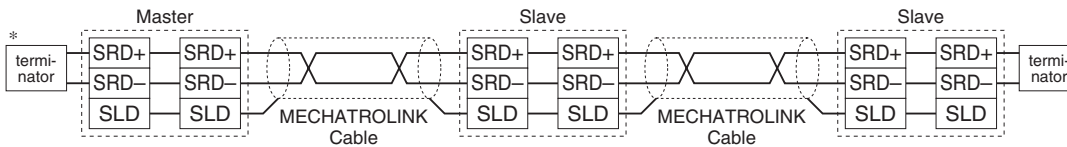

*Terminator

Be sure to connect the terminating resistors to the unit at both ends of transmission line.
 Use the terminating resistor dedicated for MECHATROLINK: Model JEPMC-W6022, Yaskawa Controls Co., Ltd.
 Certain types of Master units may have incorporated terminating resistors. Consult the instruction manual of the Master unit.

DATA CONVERSION

INPUT RANGE AND DATA CONVERSION (FACTORY DEFAULT SETTING)

Analog input data is converted into digital representations of 0 – 100% proportional to each scaled range.
 The converted % values are multiplied by 100 and expressed in 16 bits.
 Overrange input is possible from -15 to +115% of the nominal range.
 When the signal exceeds the limit, the data is fixed at -15% or +115%.

• Input Range 0 – 5V DC

Input Value	Input %	Converted Data, Decimal	Converted Data, Hex
≤ -0.75V	-15%	-1500	FA24
0V	0%	0	0
5V	100%	10000	2710
≥ 5.75V	115%	11500	2CEC

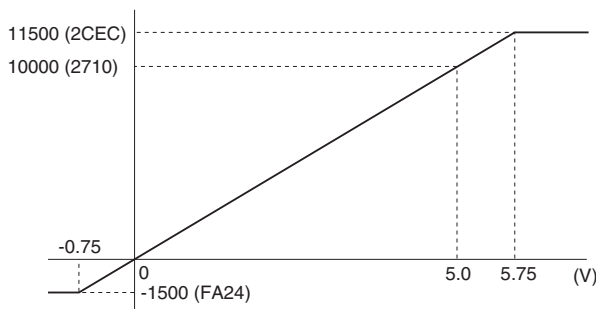

RESPONSE TIME

Response time of analog input module is time from when 0 to 100% stepwise signal change is applied to the analog module till when the communication ASIC of the module (slave) transmits 90 % of input signal.

T_{COM} : MECHATROLINK-II transmission cycle set at master
(depends on system and configuration)

T_i : Delay of input module \leq Delay of input circuit (T_a) + Conversion time^{*1} (T_b) + Input internal processing delay time (T_c) (one transmission cycle)

T_{INP} : Response time of input module $\leq T_i + T_{COM}$

*1. Conversion time x Averaging

E.g.: Averaging: 1, MECHATROLINK-II transmission cycle of 0.5 msec.

Delay of input module (T_i): Delay of input circuit (1 msec.) + Conversion time (1 msec.) x Averaging (1)
+ Input internal processing delay time (0.5 msec.) = 2.5 [msec.]

Response time of input module (T_{INP}): T_i (2.5 msec.) + T_{COM} (0.5 msec.) = 3.0 [msec.]

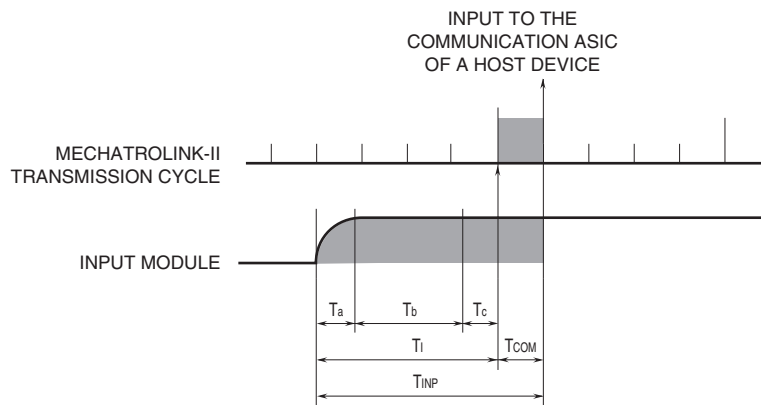

I/O DATA DESCRIPTIONS

Scaling of analog input module is configurable with the configurator software (model: R7CFG). Refer to the software manual for details.

ANALOG INPUT

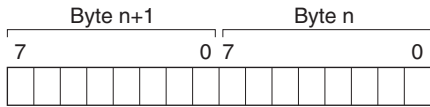

Data is represented in 16-bit binary. Negative value is represented in 2's complements.

STATUS

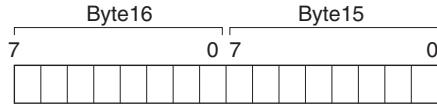

- CH0: Input range error (-15% or less, 115% or more)
- CH1: Input range error (-15% or less, 115% or more)
- CH2: Input range error (-15% or less, 115% or more)
- CH3: Input range error (-15% or less, 115% or more)
- CH0: ADC error
- CH1: ADC error
- CH2: ADC error
- CH3: ADC error
- Not used (fixed to 0)

Input range error
 0: normal, 1: error
 ADC error (no response from ADC)
 0: normal, 1: error

EXTERNAL DIMENSIONS & TERMINAL ASSIGNMENTS unit: mm [inch]

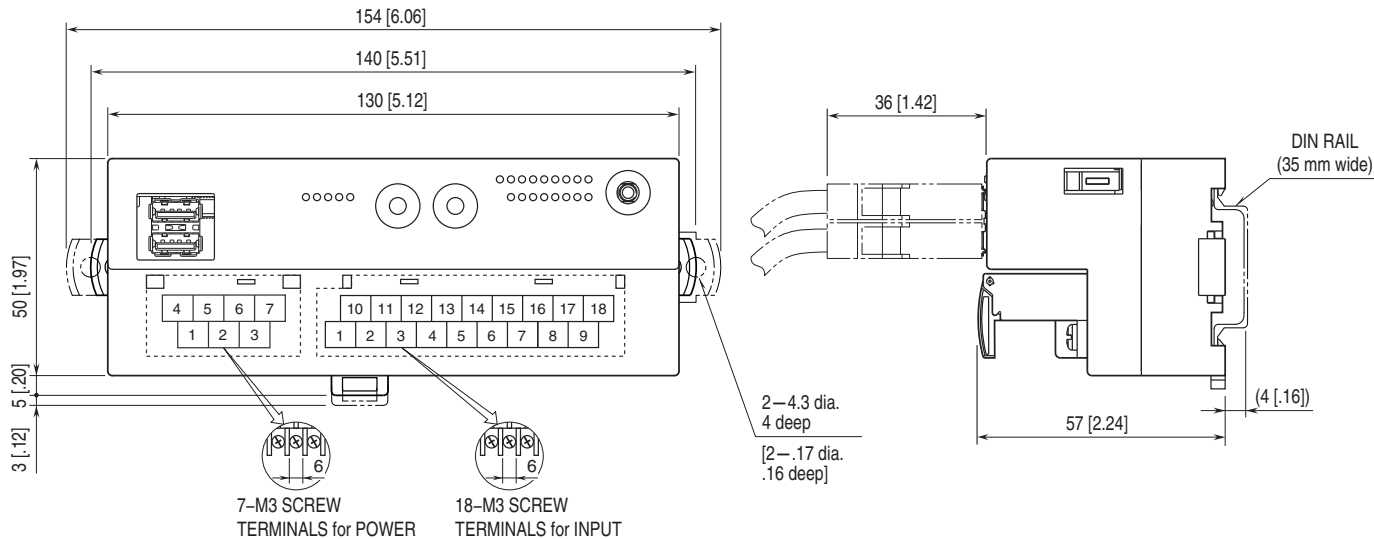

MOUNTING REQUIREMENTS unit: mm [inch]

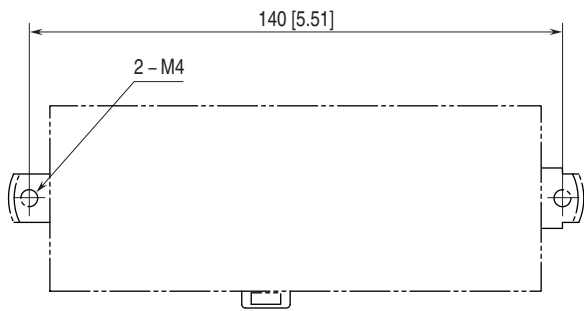

SCHEMATIC CIRCUITRY & CONNECTION DIAGRAM

Note: In order to improve EMC performance, bond the FE terminal to ground.

Caution: FE terminal is NOT a protective conductor terminal.

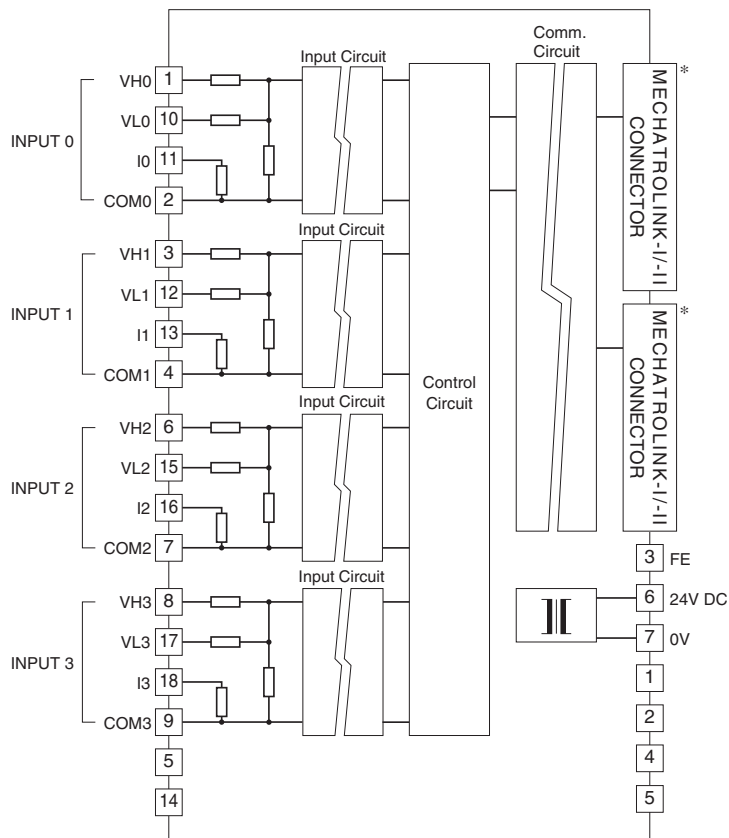

INPUT CONNECTION EXAMPLES

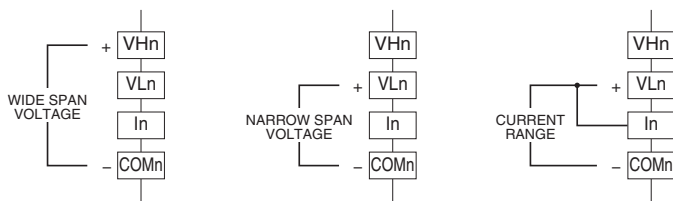

Note: Be sure \square and \square terminals are cross-wired at DC current input.

* MECHATROLINK connectors are internally connected.
The network cable can be connected to either one.



Specifications are subject to change without notice.