

Remote I/O R7 Series

MODBUS I/O MODULE

(discrete input, 16 points, 115.2 kbps)

Functions & Features

- 16 points discrete input module for Modbus
- Extension module can be connected

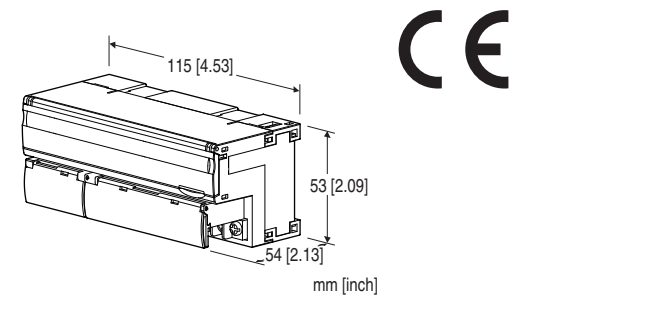

MODEL:R7M-DA16F-R[1]

ORDERING INFORMATION

- Code number: R7M-DA16F-R[1]
- Specify a code from below for [1].
(e.g. R7M-DA16F-R/Q)
- Specify the specification for option code /Q
(e.g. /C01/SET)

I/O TYPE

DA16F: Discrete input, 16 points

POWER INPUT

DC Power

R: 24 V DC

(Operational voltage range 24 V \pm 10 %, ripple 10 %p-p max.)

[1] OPTIONS

blank: none

/Q: With options (specify the specification)

SPECIFICATIONS OF OPTION: Q (multiple selections)

COATING (For the detail, refer to our web site.)

/C01: Silicone coating

/C02: Polyurethane coating

/C03: Rubber coating

EX-FACTORY SETTING

/SET: Preset according to the Ordering Information Sheet

(No. ESU-7803-AW)

RELATED PRODUCTS

- PC Configurator cable (model: MCN-CON or COP-US)
 - PC configurator software (model: R7CON)
- Downloadable at our web site.
- Discrete input extension module (model: R7M-EAx)
 - Discrete output extension module (model: R7M-ECx)

GENERAL SPECIFICATIONS

Connection: M3 separable screw terminal (torque 0.5 N·m)

Solderless terminal: Refer to the drawing at the end of the section.

Recommended manufacturer: Japan Solderless Terminal MFG. Co., Ltd., Nichifu Co., Ltd.

Applicable wire size: 0.25 to 1.65 mm² (AWG 22 to 16)

Screw terminal: Nickel-plated steel

Housing material: Flame-resistant resin (gray)

Isolation: Input to Modbus or FG to power

Extension: No extension (*), Discrete input 8 or 16 points, Discrete output 8 or 16 points

Selectable with the front DIP SW

(* Factory default setting)

Status indicator LEDs: PWR, RUN, ERR, SD, RD

(Refer to the instruction manual)

Discrete input status indicator LED: LED turns on with input ON

Configurator connection: 2.5 dia. miniature jack

■ Recommended solderless terminal

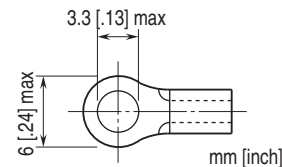

MODBUS COMMUNICATION

Standard: Conforms to TIA/EIA-485-A

Transmission distance: 500 meters max.

Transmission media: Shielded twisted-pair cable (CPEV-S 0.9 dia.)

Communication parameter: With Configurator Software (model: R7CON)

- **Data Mode:** RTU (default) or ASCII

- **Parity:** NONE (default), ODD or EVEN

- **Data bit:** 8: RTU (default), 7: ASCII

- **Stop bit:** 1 or 2 (default)

Baud rate setting: With rotary switch

115.2 kbps, 57.6 kbps, 38.4 kbps (default), 28.8 kbps, 19.2 kbps, 14.4 kbps, 9600 bps, 4800 bps, 2400 bps, 1200 bps

Node address setting: 1 - 99 (with rotary switch) (factory default setting: 00)

Terminating resistor: Built-in (Selected with the DIP SW;

factory setting: disabled)

INPUT SPECIFICATIONS

Common: Positive or negative common (NPN/PNP) per 16 points

Maximum inputs applicable at once: No limit (at 24 V DC)

Rated input voltage: 24 V DC $\pm 10\%$; ripple 5 %p-p max.

ON voltage / current: ≥ 15 V DC (input - COM) / ≥ 3.5 mA

OFF voltage / current: ≤ 5 V DC (input - COM) / ≤ 1 mA

Input current: ≤ 5.5 mA per point at 24 V DC

Input resistance: Approx. 4.4 k Ω

ON delay: ≤ 0.5 msec.

OFF delay: ≤ 1.0 msec.

INSTALLATION

Current consumption

•DC: Approx. 40 mA

Operating temperature: -10 to +55°C (14 to 131°F)

Storage temperature: -20 to +65°C (-4 to +149°F)

Operating humidity: 30 to 90 %RH (non-condensing)

Atmosphere: No corrosive gas or heavy dust

Mounting: DIN rail (35 mm rail)

Weight: 200 g (0.44 lb)

PERFORMANCE

Insulation resistance: ≥ 100 M Ω with 500 V DC

Dielectric strength: 1500 V AC @ 1 minute (input to Modbus or FG to power)

STANDARDS & APPROVALS

Refer to the manuals to comply with the standards.

EU conformity:

EMC Directive

EMI EN 61000-6-4

EMS EN 61000-6-2

RoHS Directive

EXTERNAL VIEW

■ SIDE VIEW

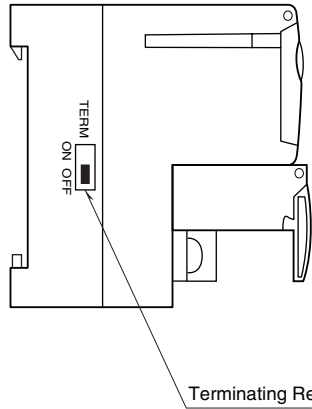

■ FRONT VIEW

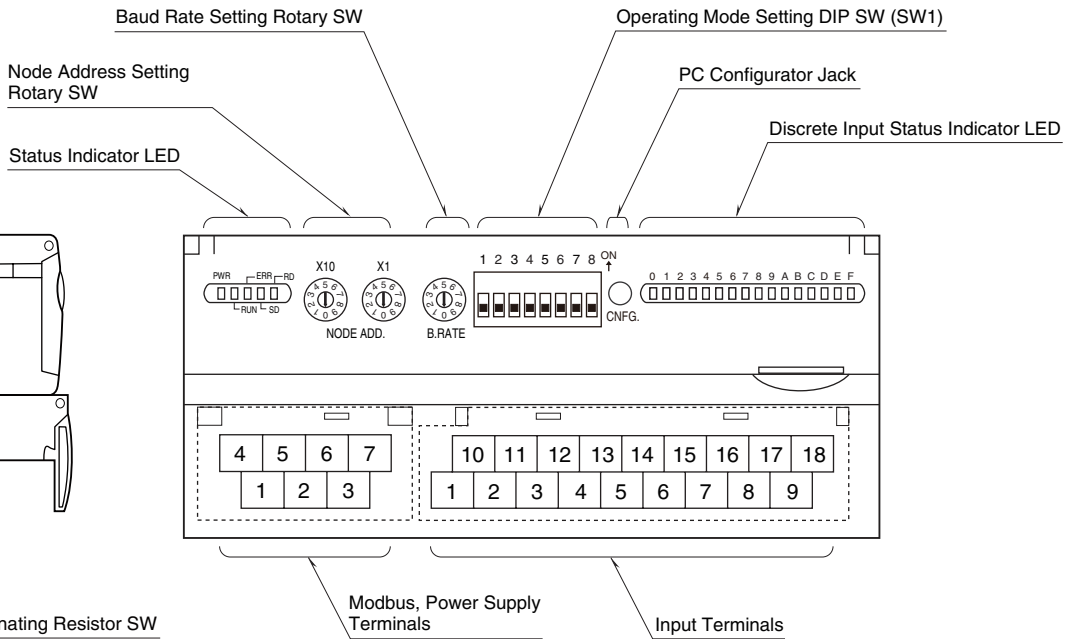

COMMUNICATION CABLE CONNECTIONS

■ MASTER CONNECTION

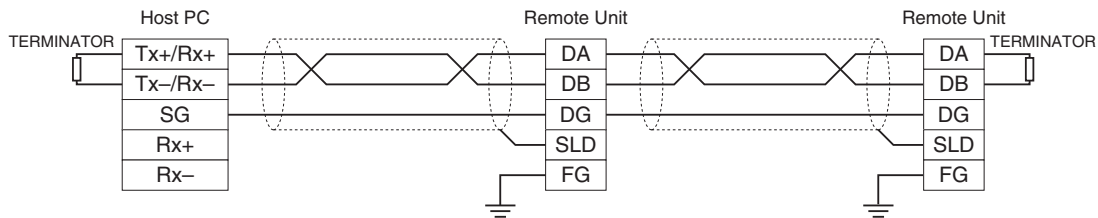

Be sure to turn on the terminating resistor setting of the units at both ends of transmission line.
 When the unit does not have a terminating resistor setting, connect a terminating resistor (110Ω, 0.25W) across DA and DB.
 The Host PC can be located other than at the extreme ends of transmission line.

TERMINAL ASSIGNMENTS

■ **INPUT TERMINAL ASSIGNMENT**

10	11	12	13	14	15	16	17	18
COM	X1	X3	X5	X7	X9	XB	XD	XF
1	2	3	4	5	6	7	8	9
COM	X0	X2	X4	X6	X8	XA	XC	XE

NO.	ID	FUNCTION	NO.	ID	FUNCTION
1	COM	Common	10	COM	Common
2	X0	Input 0	11	X1	Input 1
3	X2	Input 2	12	X3	Input 3
4	X4	Input 4	13	X5	Input 5
5	X6	Input 6	14	X7	Input 7
6	X8	Input 8	15	X9	Input 9
7	XA	Input 10	16	XB	Input 11
8	XC	Input 12	17	XD	Input 13
9	XE	Input 14	18	XF	Input 15

■ **POWER SUPPLY, MODBUS TERMINAL ASSIGNMENT**

4	5	6	7
DA	DG	+24 V	0V
1	2	3	
DB	SLD	FG	

NO.	ID	FUNCTION, NOTES
1	DB	----
2	SLD	Shield
3	FG	FG
4	DA	----
5	DG	----
6	+24 V	Power input (24 V DC)
7	0 V	Power input (0 V DC)

MODBUS FUNCTION CODES & SUPPORTED CODES

■ Data and Control Functions

CODE	NAME	
01	Read Coil Status	Digital output from the slave
02	Read Input Status	Status of digital inputs to the slave
03	Read Holding Registers	General purpose register within the slave
04	Read Input Registers	Collected data from the field by the slave
05	Force Single Coil	Digital output from the slave
06	Preset Single Register	General purpose register within the slave
08	Diagnostics	
11	Fetch Comm. Event Counter	Fetch a status word and an event counter
12	Fetch Comm. Event Log	A status word, an event counter, a message count and a field of event bytes
15	Force Multiple Coils	Digital output from the slave
16	Preset Multiple Registers	General purpose register within the slave
17	Report Slave ID	Slave type/ 'RUN' status

■ Exception Codes

CODE	NAME	
01	Illegal Function	Function code is not allowable for the slave
02	Illegal Data Address	Address is not available within the slave
03	Illegal Data Value	Data is not valid for the function

■ Diagnostic Subfunctions

CODE	NAME	
00	Return Query Data	Loop back test

MODBUS I/O ASSIGNMENT

	ADDRESS	DATA TYPE	DATA
Coil (0X)	1 – 16		Digital Output (discrete output of the basic module) (unused)
	17 – 32		Digital Output (discrete output of the extension module)
Inputs (1X)	1 – 16		Digital Input (discrete input of the basic module)
	17 – 32		Digital Input (discrete input of the extension module)
	33 – 48		Reserved (unused)
	49 – 64		Module Status
	65 – 80		Reserved (unused)
Input Registers (3X)	1 – 48	----	Analog Input (unused)
Holding Registers (4X)	1 – 48	----	Analog Output (unused)

Note: DO NOT access addresses other than mentioned above. Such access may cause problems such as inadequate operation.

■ STATUS

Bit 0 to 7: Fixed to 0.

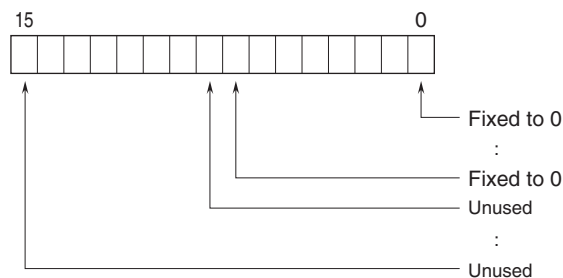

SCHEMATIC CIRCUITRY & CONNECTION DIAGRAM

Note: In order to improve EMC performance, bond the FG terminal to ground.

Caution: FG terminal is NOT a protective conductor terminal.

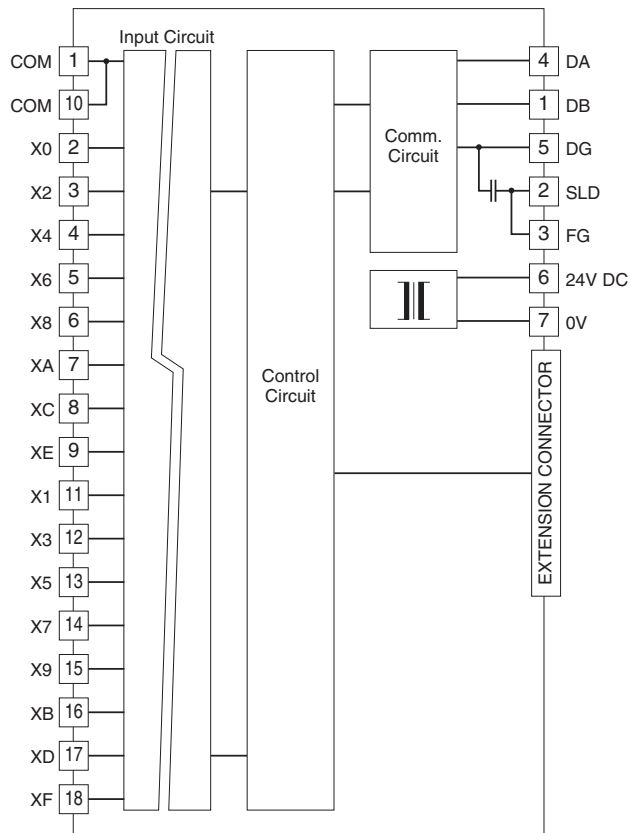

Input Circuit

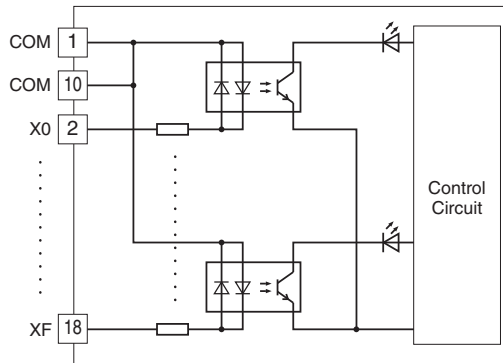

Input Connection Examples

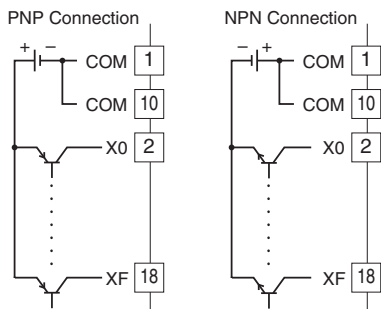



Specifications are subject to change without notice.