

Remote I/O R9 Series

MULTI POWER MONITORING UNIT

(Clamp-on current sensor CLSE, Modbus)

Functions & Features

- Multi Power Monitoring Unit for Modbus.
- By using clamp-on current sensors, there is no need of current transformers.
- Up to 8 circuits can be measured. (Common voltage measurement)
- Current sensors are easy to install in existing systems. Wide input range of 5 to 600 A is available.
- All measured values, counter values, display mode, setting data are stored in the non-volatile memory when power is off.
- By using SD card, data logging of current and power etc. with calendar is available.

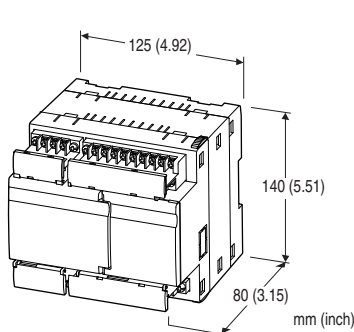

MODEL: R9MWTU-2001-AD4[1]

ORDERING INFORMATION

- Code number: R9MWTU-2001-AD4[1]
Specify a code from below for [1].
(e.g. R9MWTU-2001-AD4/Q)
- Specify the specification for option code /Q
(e.g. /C01/SET)

CONFIGURATION

2: Single-phase/2-wire, 3-phase/3-wire, single-phase/3-wire; 8 circuits

CONNECTION

0: Terminal block

I/O

0: Without

EXTENSION UNIT

- 1: With connection
(Extension unit does not conform to EU directive)

AUXILIARY POWER SUPPLY

- AD4: universal
100 - 240 V AC (Operational range 85 - 264 V, 50 / 60 Hz) /
110 - 240 V DC (Operational range 99 - 264 V,
ripple 10 %p-p max)

[1] OPTIONS

- blank: none
- /Q: With options (specify the specification)

SPECIFICATIONS OF OPTION: Q (multiple selections)

- COATING (For the detail, refer to our web site.)
- /C01: Silicone coating
- /C02: Polyurethane coating
- /C03: Rubber coating
- EX-FACTORY SETTING
- /SET: Preset according to the Ordering Information Sheet
(No. ESU-6221)

RELATED PRODUCTS

- Discrete I/O extension unit (model: R9WTU-ED)
- Multi power monitoring extension unit (model: R9WTU-EP)
- PC configurator software (model: PMCFG)
Software downloadable at our web site.
- A dedicated cable is required to connect the module to the PC. Please refer to the internet software download site or the users manual for the PC configurator for applicable cable types.
- Clamp-on current sensor (model: CLSE)
The clamp-on current sensors, not included in this product package, must be ordered separately. Required number depends upon the system configuration.
- SD card
A SD card is required to store data in the unit. Use the specified model number of memory card. Available for purchase from us. Consult us.
- Hagiwara Solutions NSD6-004GH(B21SEI)
(NSD6-004GH(A00SDI, NSDA-004GT,
NSDA-004GL ... discontinued)
- Apacer Technology AP-ISD04GIS4B-3T
(AP-ISD04GIS4B-T ... discontinued)

GENERAL SPECIFICATIONS

- Construction: Stand-alone
- Degree of protection: IP20
- Connection

Auxiliary power or voltage input: M3.5 screw terminals (torque 0.8 N·m)

Current input: M3 screw terminals (torque 0.5 N·m)

Modbus: M3 screw terminals (torque 0.5 N·m)

Solderless terminal: Refer to the drawing at the end of the section.

Recommended manufacturer: Japan Solderless Terminal MFG.Co.Ltd, Nichifu Co.,Ltd

Applicable wire size

M3 screw terminal: 0.25 to 1.65 mm² (AWG 22 to 16)

M3.5 screw terminal: 1.04 to 2.63 mm² (AWG 16 to 14)

Configuration: Single-phase/2-wire, single-phase/3-wire, 3-phase/3-wire

Screw terminal: Nickel-plated steel

Housing material: Flame-resistant resin (black)

Isolation: Sensor core to sensor output or current input or voltage input to Modbus to auxiliary power to FE1

■ **Measured variables**

Voltage: R - N, S - N, T - N, R - S, S - T, T - R

Current: R, S, T, N

Active / reactive / apparent power: R, S, T, Σ

Power factor: R, S, T, Σ

Frequency

Active energy: Incoming

Reactive energy: Incoming lag

Active / reactive / apparent power intervals (demand)

Average (demand) current: R, S, T, N

Harmonic contents: Σ

Voltage: R - N, S - N, T - N, R - S, S - T, T - R

Current: R, S, T, N

Max. and min. values

Calendar log (inserting SD card): Voltage, Current, power, electric energy, power factor

Operating mode setting: Connection, clamp-on sensor selection

Status indicators: Power, SD Card

■ **Recommended solderless terminal size - M3**

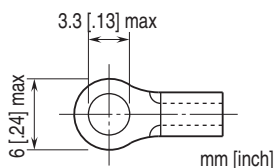

■ **Recommended solderless terminal size - M3.5**

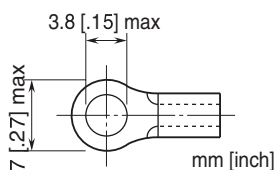

MODBUS COMMUNICATION

Communication: Half-duplex, asynchronous, no procedure

Standard: Conforms to TIA/EIA-485-A

Transmission distance: 500 meters max.

Transmission media: Shielded twisted-pair cable (CPEV-S 0.9 dia.)

Protocol: Modbus - RTU (default) or Modbus - ASCII

Max. number of nodes: 31 (excluding master)

Node address setting: 1 - 99 (with rotary switch) (factory default setting: 00)

Baud rate setting: With rotary switch 38.4 kbps (default), 19.2 kbps, 9600 bps, 4800 bps

Status indicator LED: Run, RD, SD, ERR

Terminating resistor: Built-in (Selected with the DIP SW; factory setting: disabled)

INPUT SPECIFICATIONS

Frequency: 50 / 60 Hz (45 - 65 Hz)

• **Voltage Input**

Rated voltage

• **Between lines:** 400 V AC

• **Line-neutral (phase voltage):** 230 V (single-phase / 2-wire and 3-wire)

Input burden: ≤ $U_{in}^2 / 300$ kΩ / phase

Overload capacity: 200 % of rating for 10 sec., 120 % continuous

Selectable primary voltage range: 50 - 400 000 V

• **Current Input**

CLSE-R5: 0 - 5 A AC

CLSE-05: 0 - 50 A AC

CLSE-10: 0 - 100 A AC

CLSE-20: 0 - 200 A AC

CLSE-40: 0 - 400 A AC

CLSE-60: 0 - 600 A AC

Overload capacity: 120 % continuous, 500 % for 10 sec.

Note: Use for the circuit not exceed 480 V

Selectable primary current range: 1 - 20 000 A (Using CLSE-R5 the unit is configurable only with configurator software.)

Operational range

Current: 0 - 120 % of the rating

Voltage: 10 - 120 % of the rating

Apparent power: ≤ 120 % of the rating

Active/reactive power: ±120 % of the rating

Frequency: 45 - 65 Hz

Power factor: ±1

INSTALLATION

Auxiliary power supply

• **AC:** < 7 VA

• **DC:** < 1.2 W

Operating temperature: -10 to +55°C (14 to 131°F)

Operating humidity: 30 to 90 %RH (non-condensing)

Atmosphere: No corrosive gas or heavy dust

Mounting: Surface or DIN rail

Weight: 500 g (1.1 lb)

PERFORMANCE

Accuracy (at 10 - 35°C or 50 - 95°F, 45 - 65 Hz)^{*1}

Add the accuracy of the current sensor for overall values.

Voltage: ± 0.5 % of the rating^{*2}

Current: ± 0.5 % of the rating^{*2}

Power: ± 0.5 % of the rating^{*2}

Power factor: ± 1.5 %

Frequency: ± 0.1 % of the rating^{*2}

Energy: ± 1 %

Harmonic contents: ± 2 % of the rating^{*2}

*1. Sensor error margin not included

*2. The described accuracy levels are ensured at the input
1% or more for neutral current in a 1-phase/3-wire circuit
and phase-S current in an unbalanced 3-phase/3-wire
circuit.

Data update period:

Harmonic contents and frequency: ≤ 1 sec.

Other: ≤ 500 msec.

Calendar clock: (with battery backup)

Accuracy: Monthly deviation 3 minutes at 25°C

Back up period: Approx. 2 years at 25°C without power

With the power on, no battery drain

Battery: Primary lithium battery (non-removable)

Insulation resistance: ≥ 100 M Ω with 500 V DC

Dielectric strength: 2000 V AC @ 1 minute

(current input or voltage input to Modbus to auxiliary power
or FE1)

STANDARDS & APPROVALS

EU conformity:

EMC Directive

EMI EN 61000-6-4

EMS EN 61000-6-2

Low Voltage Directive

EN 61010-1, EN 61010-2-201

Measurement Category II (input)

Installation Category II (auxiliary power)

Pollution Degree 2

Input to Modbus: Reinforced insulation (400 V)

Input or Modbus to auxiliary power: Reinforced insulation
(300 V)

RoHS Directive

EXTERNAL VIEW

FRONT VIEW

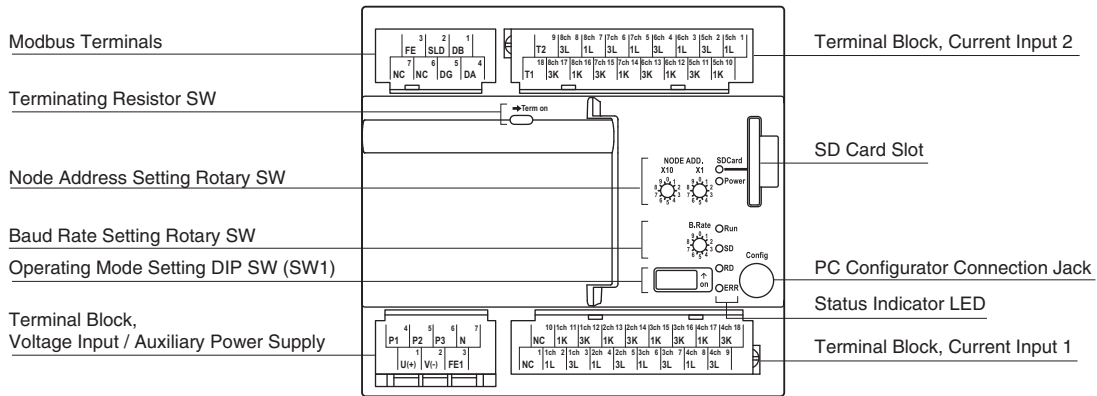

TERMINAL CONNECTIONS

Use the model CLSE clamp sensor for current inputs.

The figure below shows only one circuit.

A maximum of eight (8) current sensor inputs can be connected (Ch. 1 through Ch. 8).

Grounding is not required for low voltage circuits.

System / Application	Terminal	System / Application	Terminal
Single-phase / 2-wire		Three-phase / 3-wire balanced load	
Single-phase / 3-wire		Three-phase / 3-wire unbalanced load	

COMMUNICATION CABLE CONNECTIONS

MASTER CONNECTION

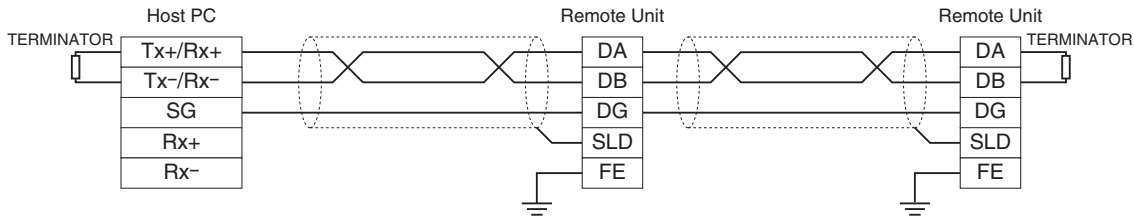

Be sure to connect the terminating resistor across DA and DB at both ends of communication line.
When this unit is located at an end, turn the terminating resistor SW ON.
The Host PC can be located at not only both ends but also any node of the of communication line.

TERMINAL ASSIGNMENTS

• Modbus

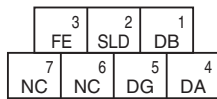

No.	ID	FUNCTION
1	DB	DB
2	SLD	Shield
3	FE	Modbus ground
4	DA	DA
5	DG	DG
6	NC	Unused
7	NC	Unused

• Current Input 2

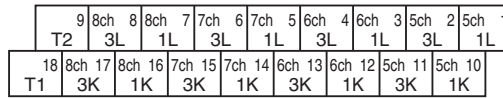

No.	ID	FUNCTION	No.	ID	FUNCTION
1	5ch 1L	Ch.5, Current input 1L	10	5ch 1K	Ch.5, Current input 1K
2	5ch 3L	Ch.5, Current input 3L	11	5ch 3K	Ch.5, Current input 3K
3	6ch 1L	Ch.6, Current input 1L	12	6ch 1K	Ch.6, Current input 1K
4	6ch 3L	Ch.6, Current input 3L	13	6ch 3K	Ch.6, Current input 3K
5	7ch 1L	Ch.7, Current input 1L	14	7ch 1K	Ch.7, Current input 1K
6	7ch 3L	Ch.7, Current input 3L	15	7ch 3K	Ch.7, Current input 3K
7	8ch 1L	Ch.8, Current input 1L	16	8ch 1K	Ch.8, Current input 1K
8	8ch 3L	Ch.8, Current input 3L	17	8ch 3K	Ch.8, Current input 3K
9	T2	Unused	18	T1	Unused

• Auxiliary Power Supply, Voltage Input

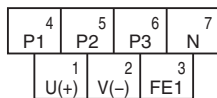

No.	ID	FUNCTION
1	U(+)	Auxiliary power (+)
2	V(-)	Auxiliary power (-)
3	FE1	Power ground
4	P1	Voltage input P1
5	P2	Voltage input P2
6	P3	Voltage input P3
7	N	Voltage input N

• Current Input 1

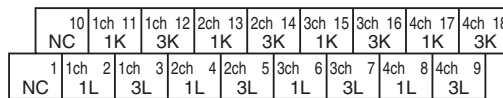

No.	ID	FUNCTION	No.	ID	FUNCTION
1	NC	Unused	10	NC	Unused
2	1ch 1L	Ch.1, Current input 1L	11	1ch 1K	Ch.1, Current input 1K
3	1ch 3L	Ch.1, Current input 3L	12	1ch 3K	Ch.1, Current input 3K
4	2ch 1L	Ch.2, Current input 1L	13	2ch 1K	Ch.2, Current input 1K
5	2ch 3L	Ch.2, Current input 3L	14	2ch 3K	Ch.2, Current input 3K
6	3ch 1L	Ch.3, Current input 1L	15	3ch 1K	Ch.3, Current input 1K
7	3ch 3L	Ch.3, Current input 3L	16	3ch 3K	Ch.3, Current input 3K
8	4ch 1L	Ch.4, Current input 1L	17	4ch 1K	Ch.4, Current input 1K
9	4ch 3L	Ch.4, Current input 3L	18	4ch 3K	Ch.4, Current input 3K

EXTERNAL DIMENSIONS unit: mm [inch]

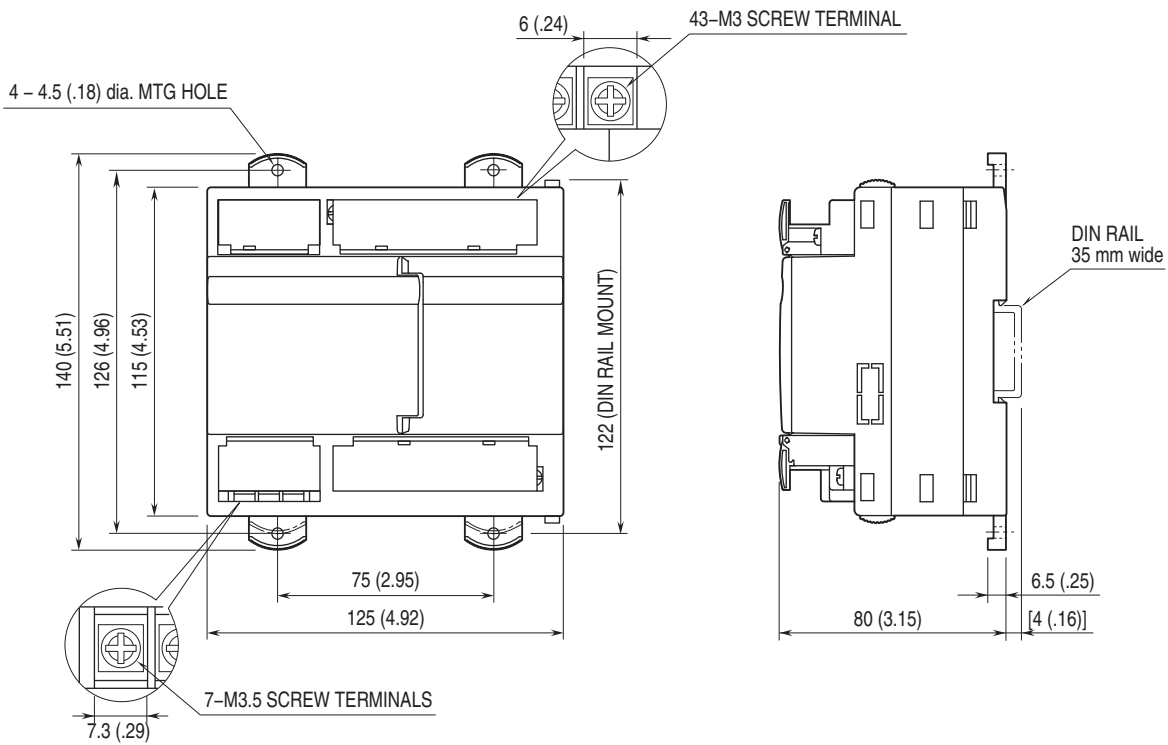

MOUNTING REQUIREMENTS unit: mm [inch]

■ SINGLE MOUNTING

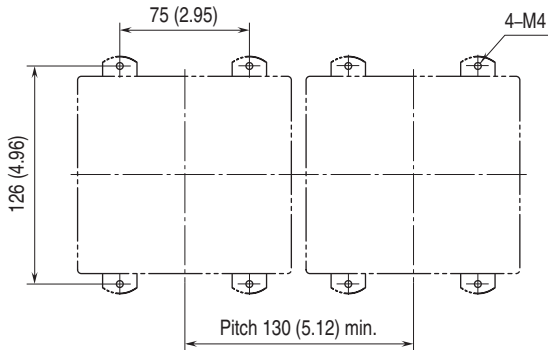

■ BASIC + EXTENSION UNIT

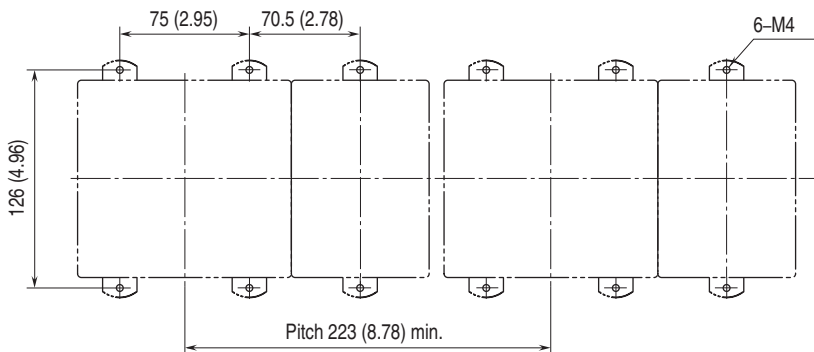

SCHEMATIC CIRCUITRY & CONNECTION DIAGRAM

Note: In order to improve EMC performance, bond the FE1 terminal to ground.

Caution: FE1 terminal is NOT a protective conductor terminal.

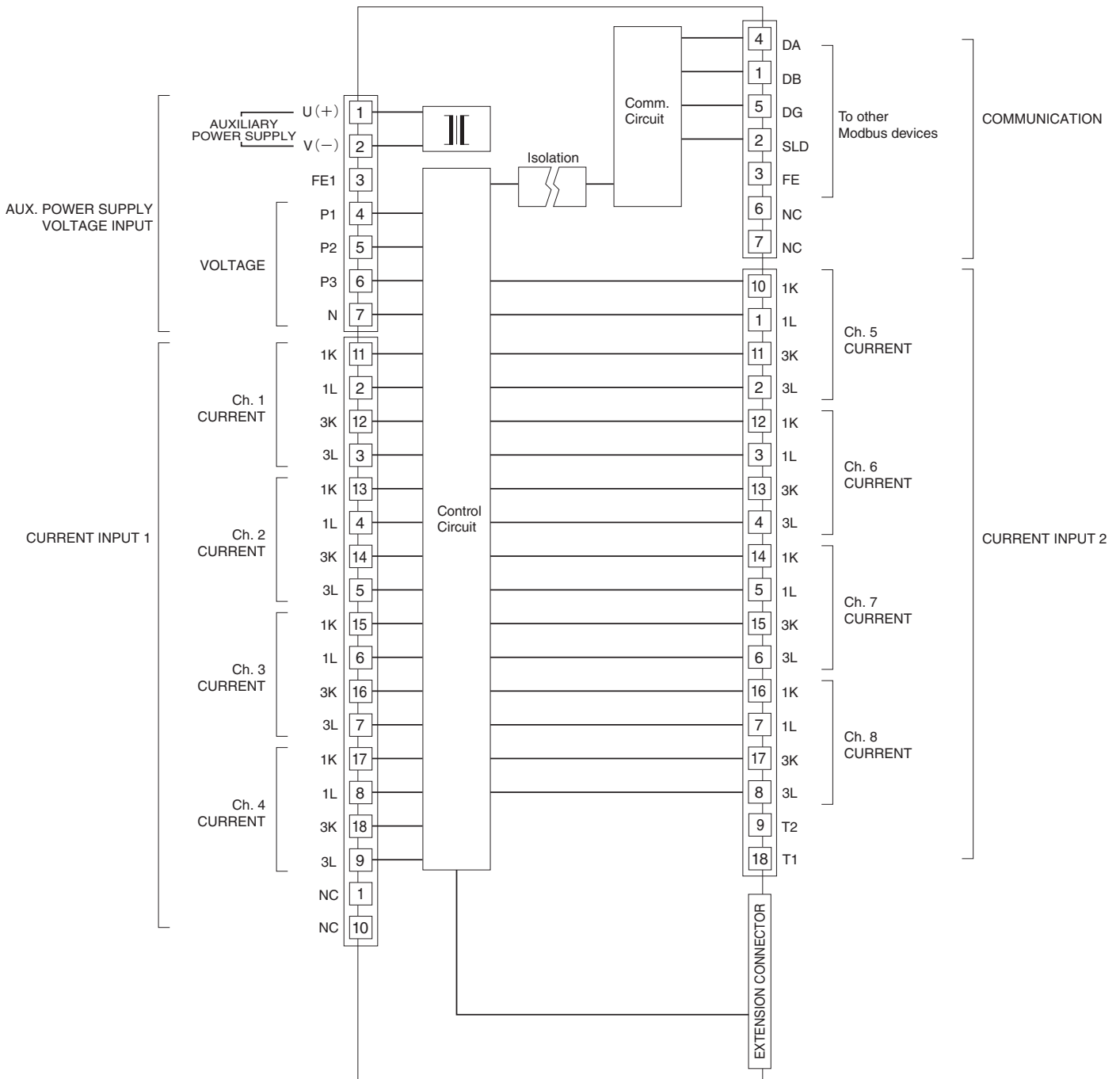

Specifications are subject to change without notice.