

Plug-in Signal Conditioners M-UNIT

SIGNAL TRANSMITTER

(isolated; max. 200 mA output)

Functions & Features

- Converting a DC process input into a high-power current or voltage up to 200 mA
- Isolation up to 2000 V AC
- High-density mounting

Typical Applications

- Retrofitting 10 - 50 mA DC control system
- DC excitation for an electromagnetic coil which demands a high power

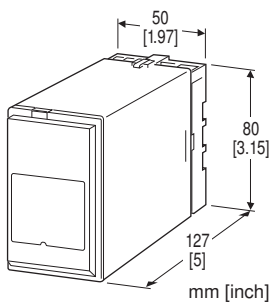

MODEL: SVA-[1][2]-[3][4]

ORDERING INFORMATION

- Code number: SVA-[1][2]-[3][4]
- Specify a code from below for each of [1] through [4]. (e.g. SVA-AN-K3/Q)
- Special input and output ranges (For codes Z & 0)
- Specify the specification for option code /Q (e.g. /C01/S01)

[1] INPUT

Current

- A:** 4 - 20 mA DC (Input resistance 250 Ω)
- A1:** 4 - 20 mA DC (Input resistance 50 Ω)
- B:** 2 - 10 mA DC (Input resistance 500 Ω)
- C:** 1 - 5 mA DC (Input resistance 1000 Ω)
- D:** 0 - 20 mA DC (Input resistance 50 Ω)
- E:** 0 - 16 mA DC (Input resistance 62.5 Ω)
- F:** 0 - 10 mA DC (Input resistance 100 Ω)
- G:** 0 - 1 mA DC (Input resistance 1000 Ω)
- H:** 10 - 50 mA DC (Input resistance 100 Ω)
- J:** 0 - 10 μA DC (Input resistance 1000 Ω)
- K:** 0 - 100 μA DC (Input resistance 1000 Ω)
- GW:** -1 - +1 mA DC (Input resistance 1000 Ω)
- FW:** -10 - +10 mA DC (Input resistance 100 Ω)

Z: Specify current (See INPUT SPECIFICATIONS)
Voltage

- 1:** 0 - 10 mV DC (Input resistance 10 kΩ min.)
- 15:** 0 - 50 mV DC (Input resistance 10 kΩ min.)
- 16:** 0 - 60 mV DC (Input resistance 10 kΩ min.)
- 2:** 0 - 100 mV DC (Input resistance 100 kΩ min.)
- 3:** 0 - 1 V DC (Input resistance 1 MΩ min.)
- 4:** 0 - 10 V DC (Input resistance 1 MΩ min.)
- 5:** 0 - 5 V DC (Input resistance 1 MΩ min.)
- 6:** 1 - 5 V DC (Input resistance 1 MΩ min.)
- 4W:** -10 - +10 V DC (Input resistance 1 MΩ min.)
- 5W:** -5 - +5 V DC (Input resistance 1 MΩ min.)
- 0:** Specify voltage (See INPUT SPECIFICATIONS)

[2] OUTPUT

Current

- H:** 10 - 50mA DC (Load resistance 400 Ω max.)
- L:** 0 - 50 mA DC (Load resistance 400 Ω max.)
- M:** 0 - 100 mA DC (Load resistance 200 Ω max.)
- N:** 0 - 200 mA DC (Load resistance 50 Ω max.)
- Z:** Specify current (See OUTPUT SPECIFICATIONS)
- Voltage
- 4:** 0 - 10 V DC (Load resistance 50 Ω min.)
- 5:** 0 - 5 V DC (Load resistance 25 Ω min.)
- 6:** 1 - 5 V DC (Load resistance 25 Ω min.)
- 8:** 0 - 20 V DC (Load resistance 200 Ω min.)
- 0:** Specify voltage (See OUTPUT SPECIFICATIONS)

[3] POWER INPUT

AC Power

- K3:** 100 - 120 V AC
(Operational voltage range 90 - 132 V, 47 - 66 Hz)
- L3:** 200 - 240 V AC
(Operational voltage range 180 - 264 V, 47 - 66 Hz)

DC Power

- P:** 110 V DC
(Operational voltage range 85 - 150 V, ripple 10 %p-p max.)

[4] OPTIONS

- blank:** none
- /Q:** With options (specify the specification)

SPECIFICATIONS OF OPTION: Q (multiple selections)

COATING (For the detail, refer to our web site.)

- /C01:** Silicone coating
- /C02:** Polyurethane coating
- /C03:** Rubber coating
- TERMINAL SCREW MATERIAL
- /S01:** Stainless steel

GENERAL SPECIFICATIONS

Construction: Plug-in
Connection: M3.5 screw terminals
Screw terminal: Chromated steel (standard) or stainless steel
Housing material: Flame-resistant resin (black)
Isolation: Input to output to power
Overrange output: 0 mA or 0 V up to 105 % of upper range value
Zero adjustment: -25 - +25 % no output below 0 mA or 0 V (front)
Span adjustment: 50 to 100 % for the rated input span (front)

INPUT SPECIFICATIONS

■ **DC Current:**
 Shunt resistor attached to the input terminals (0.5 W)
 Specify input resistance value for code Z.
 ■ **DC Voltage:** -30 - +30 V DC
Span: Min. 3 mV, max. 30 V
Offset: Max. 1.5 times span
Input resistance
 Span 3 - 10 mV : $\geq 10 \text{ k}\Omega$
 Span 10 - 100 mV : $\geq 10 \text{ k}\Omega$
 Span 0.1 - 1 V : $\geq 100 \text{ k}\Omega$
 Span $\geq 1 \text{ V}$: $\geq 1 \text{ M}\Omega$

OUTPUT SPECIFICATIONS

■ **DC Current:** 0 - 200 mA DC
Minimum span: 20 mA
Zero suppression: max. 30 % of span
Load inductance: 1 H max.
Load resistance
Max. current $\leq 100 \text{ mA}$: Output drive max. 20 V
100 mA < max. current $\leq 200 \text{ mA}$: $R_L [\Omega] = 2 [W] / (\text{max. current [A]})^2$
 ■ **DC Voltage:** 0 - 20 V DC
Minimum span: 2 V
Zero suppression: Max. 30 % of span
Load resistance
Max. voltage $\leq 10 \text{ V}$: $R_L [\Omega] = \text{max. voltage [V]} / 0.2 [\text{A}]$
10 V < max. voltage $\leq 20 \text{ V}$: $R_L [\Omega] = (\text{max. voltage [V]})^2 / 2 [W]$

INSTALLATION

Power consumption
 •AC: Approx. 10 VA, 5 W max.
 •DC: $\leq 5 \text{ W}$
Operating temperature: -5 to + 50°C (23 to 122°F)
Operating humidity: 30 to 90 %RH (non-condensing)
Mounting: Surface or DIN rail

Weight: 300 g (0.66 lb)

PERFORMANCE in percentage of span

Accuracy: $\pm 0.2 \%$
Temp. coefficient: $\pm 0.02 \%/^{\circ}\text{C}$ ($\pm 0.01 \%/^{\circ}\text{F}$)
Response time: $\leq 0.5 \text{ sec.}$ (0 - 90 %)
Load effect
Current output: $\pm 0.2 \%$ over load range
Voltage output: $+0.2 \%$ or $- \{ 0.2 + (0.3 [\Omega] \times \text{max. load [A]}) / \text{output span [V]} \times 100 \} \%$ over load range
Line voltage effect: $\pm 0.2 \%$ over voltage range
Insulation resistance: $\geq 100 \text{ M}\Omega$ with 500 V DC
Dielectric strength: 2000 V AC @1 minute (input to output to power to ground)

STANDARDS & APPROVALS

EU conformity:
 EMC Directive
 EMI EN 61000-6-4
 EMS EN 61000-6-2
 Low Voltage Directive
 EN 61010-1
 Measurement Category II
 Pollution Degree 2
 Input or output to power: Reinforced insulation (300 V)
 Input to output: Basic insulation (300 V)
 RoHS Directive

EXTERNAL DIMENSIONS unit: mm [inch]

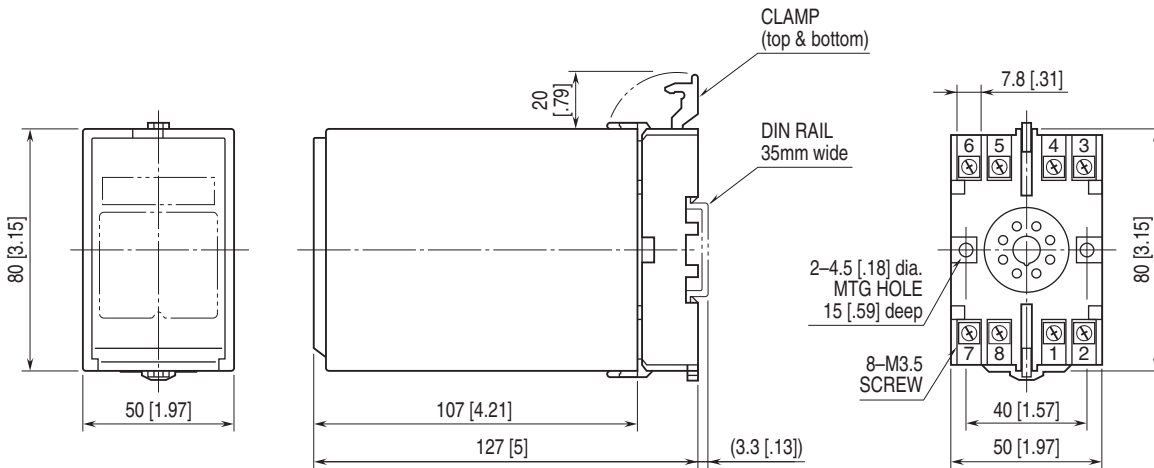

• When mounting, no extra space is needed between units.

TERMINAL ASSIGNMENTS unit: mm [inch]

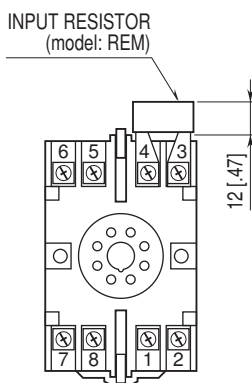

Input shunt resistor attached for current input.

SCHEMATIC CIRCUITRY & CONNECTION DIAGRAM

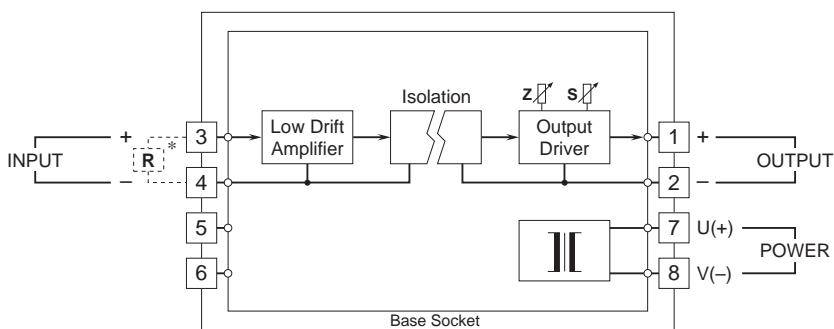

*Input shunt resistor attached for current input.



Specifications are subject to change without notice.