

**Plug-in Signal Conditioners M-UNIT**

**INVERTED OUTPUT TRANSMITTER**

(non-isolated)

**Functions & Features**

- Providing a reversed output proportional to the input signal
- LCD meter indicates inverted values (engineering unit display selectable)
- Simple loop test output (0 % and 100 %)
- High-density mounting

**Typical Applications**

- Matching manipulating signal with the valve action

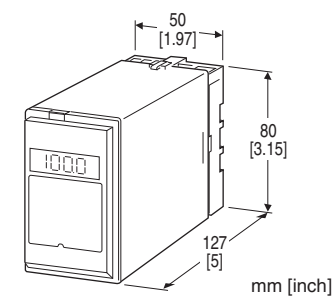

**MODEL: UD-[1][2]-[3][4]**

**ORDERING INFORMATION**

- Code number: UD-[1][2]-[3][4]
- Specify a code from below for each of [1] through [4]. (e.g. UD-6A-B/E2/Q)
- Special input and output ranges (For codes Z & 0)
- Specify the specification for option code /Q (e.g. /C01/S01)

**[1] INPUT**

Current

- A:** 4 - 20 mA DC (Input resistance 250 Ω)
- A1:** 4 - 20 mA DC (Input resistance 50 Ω)
- B:** 2 - 10 mA DC (Input resistance 500 Ω)
- C:** 1 - 5 mA DC (Input resistance 1000 Ω)
- D:** 0 - 20 mA DC (Input resistance 50 Ω)
- E:** 0 - 16 mA DC (Input resistance 62.5 Ω)
- F:** 0 - 10 mA DC (Input resistance 100 Ω)
- G:** 0 - 1 mA DC (Input resistance 1000 Ω)
- H:** 10 - 50 mA DC (Input resistance 100 Ω)
- J:** 0 - 10 μA DC (Input resistance 1000 Ω)
- K:** 0 - 100 μA DC (Input resistance 1000 Ω)
- GW:** -1 - +1 mA DC (Input resistance 1000 Ω)
- FW:** -10 - +10 mA DC (Input resistance 100 Ω)

**Z:** Specify current (See INPUT SPECIFICATIONS)  
Voltage

- 1:** 0 - 10 mV DC (Input resistance 10 kΩ min.)
- 15:** 0 - 50 mV DC (Input resistance 10 kΩ min.)
- 16:** 0 - 60 mV DC (Input resistance 10 kΩ min.)
- 2:** 0 - 100 mV DC (Input resistance 100 kΩ min.)
- 3:** 0 - 1 V DC (Input resistance 1 MΩ min.)
- 4:** 0 - 10 V DC (Input resistance 1 MΩ min.)
- 5:** 0 - 5 V DC (Input resistance 1 MΩ min.)
- 6:** 1 - 5 V DC (Input resistance 1 MΩ min.)
- 4W:** -10 - +10 V DC (Input resistance 1 MΩ min.)
- 5W:** -5 - +5 V DC (Input resistance 1 MΩ min.)
- 0:** Specify voltage (See INPUT SPECIFICATIONS)

**[2] OUTPUT**

Current

- A:** 20 - 4 mA DC (Load resistance 750 Ω max.)
- B:** 10 - 2 mA DC (Load resistance 1500 Ω max.)
- C:** 5 - 1 mA DC (Load resistance 3000 Ω max.)
- D:** 20 - 0 mA DC (Load resistance 750 Ω max.)
- E:** 16 - 0 mA DC (Load resistance 900 Ω max.)
- F:** 10 - 0 mA DC (Load resistance 1500 Ω max.)
- G:** 1 - 0 mA DC (Load resistance 15 kΩ max.)
- Z:** Specify current (See OUTPUT SPECIFICATIONS)

Voltage

- 1:** 10 - 0 mV DC (Load resistance 10 kΩ min.)
- 2:** 100 - 0 mV DC (Load resistance 100 kΩ min.)
- 3:** 1 - 0 V DC (Load resistance 100 Ω min.)
- 4:** 10 - 0 V DC (Load resistance 1000 Ω min.)
- 5:** 5 - 0 V DC (Load resistance 500 Ω min.)
- 6:** 5 - 1 V DC (Load resistance 500 Ω min.)
- 4W:** +10 - -10 V DC (Load resistance 2000 Ω min.)
- 5W:** +5 - -5 V DC (Load resistance 1000 Ω min.)
- 0:** Specify voltage (See OUTPUT SPECIFICATIONS)

**[3] POWER INPUT**

AC Power

- B:** 100 V AC
- C:** 110 V AC
- D:** 115 V AC
- F:** 120 V AC
- G:** 200 V AC
- H:** 220 V AC
- J:** 240 V AC

DC Power

- S:** 12 V DC
- R:** 24 V DC
- V:** 48 V DC
- P:** 110 V DC (Not selectable with Option /E2.)

**[4] OPTIONS (multiple selections)**

LCD Meter (after inversion)

**blank:** Without

**/E:** With (0.0 - 100.0 % display)

**/E2:** With (in engineering unit with backlight and the simple loop test output)

Other Options

**blank:** none

**/Q:** Option other than the above (specify the specification)

**SPECIFICATIONS OF OPTION: Q (multiple selections)**

COATING (For the detail, refer to our web site.)

**/C01:** Silicone coating

**/C02:** Polyurethane coating

**/C03:** Rubber coating

TERMINAL SCREW MATERIAL

**/S01:** Stainless steel

**GENERAL SPECIFICATIONS**

**Construction:** Plug-in

**Connection:** M3.5 screw terminals

**Screw terminal:** Chromated steel (standard) or stainless steel

**Housing material:** Flame-resistant resin (black)

**Isolation:** Input or output to power

**Overrange output:** Approx. -10 to +120 % at 5 - 1 V

**Zero adjustment:** -5 to +5 % (front)

**Span adjustment:** 95 to 105 % (front)

**Simple loop test output:** 0 % and 100 % signal simulated by selecting the front switch positions. (Only for option code /E2)

■ **DISPLAY (LCD meter)**

• **Option code:** /E

**LCD digital display:** 0.0 - 100.0 % (min. digit 0.1 %)  
(No scaling)

• **Option code:** /E2

**LCD digital display:** Engineering unit

**Display scaling:** -10000 - +10000

**Decimal position:**  $10^{-1}$  -  $10^{-4}$  or no decimal point

**Engineering unit:** %,  $\mu$ V, mV, V, mA, A, °C, °F,  $\Omega$ , DEG K, mHz, Hz, kHz, VAC, AAC, mg, g, kg, t, rpm or rps selectable

**Back light:** Green at normal, red at loop test output enable

**Factory setting:** scaling 0.00 - 100.00, unit: %

**INPUT SPECIFICATIONS**

■ **DC Current:**

Shunt resistor attached to the input terminals (0.5 W)

Specify input resistance value for code Z.

■ **DC Voltage:** -300 - +300 V DC

**Minimum span:** 3 mV

**Offset:** Max. 1.5 times span

**Input resistance**

Span 3 - 10 mV :  $\geq 10 \text{ k}\Omega$

Span 10 - 100 mV :  $\geq 10 \text{ k}\Omega$

Span 0.1 - 1 V :  $\geq 100 \text{ k}\Omega$

Span  $\geq 1 \text{ V}$  :  $\geq 1 \text{ M}\Omega$

**OUTPUT SPECIFICATIONS**

■ **DC Current:** 0 - 20 mA DC

**Minimum span:** 1 mA

**Offset:** Max. 1.5 times span

**Load resistance:** Output drive 15 V max.

■ **DC Voltage:** -10 - +12 V DC

**Minimum span:** 5 mV

**Offset:** Max. 1.5 times span

**Load resistance:** Output drive 10 mA max.; 5 mA for negative voltage output; at  $\geq 0.5 \text{ V}$

**INSTALLATION****Power input**

• **AC:** Operational voltage range: rating  $\pm 10 \%$ , 50/60  $\pm 2 \text{ Hz}$ , approx. 2 VA

(approx. 3 VA with Option /E2)

• **DC:** Operational voltage range: rating  $\pm 10 \%$ , or 85 - 150 V for 110 V rating (ripple 10 % p-p max.) approx. 2 W (90 mA at 24 V; approx. 3 W with Option /E2)

**Operating temperature:** -5 to +60°C (23 to 140°F)

**Operating humidity:** 30 to 90 %RH (non-condensing)

**Mounting:** Surface or DIN rail

**Weight:** 400 g (0.88 lb)

**PERFORMANCE in percentage of span**

**Accuracy:**  $\pm 0.1 \%$

**Display accuracy:**  $\pm(0.1 \%$  of FS + 1 digit)

**Simple loop test output setting accuracy:**  $\pm 0.5 \%$

**Temp. coefficient:**  $\pm 0.015 \%$ /°C ( $\pm 0.008 \%$ /°F)

**Response time:**  $\leq 0.5 \text{ sec.}$  (0 - 90 %)

**Line voltage effect:**  $\pm 0.1 \%$  over voltage range

**Insulation resistance:**  $\geq 100 \text{ M}\Omega$  with 500 V DC

**Dielectric strength:** 2000 V AC @1 minute (input or output to power to ground)

## EXTERNAL VIEW

■ OPTION /E

■ OPTION /E2

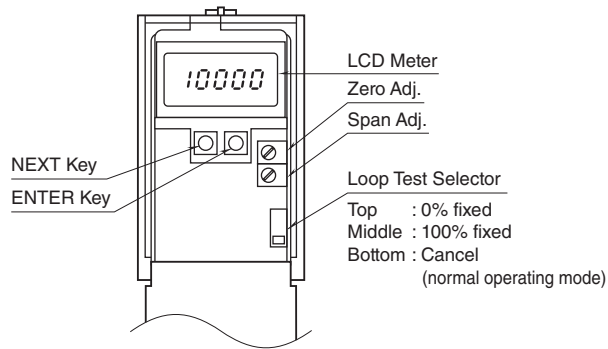
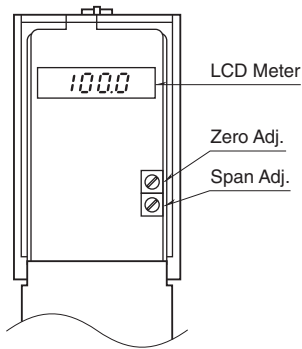

## EXTERNAL DIMENSIONS unit: mm [inch]

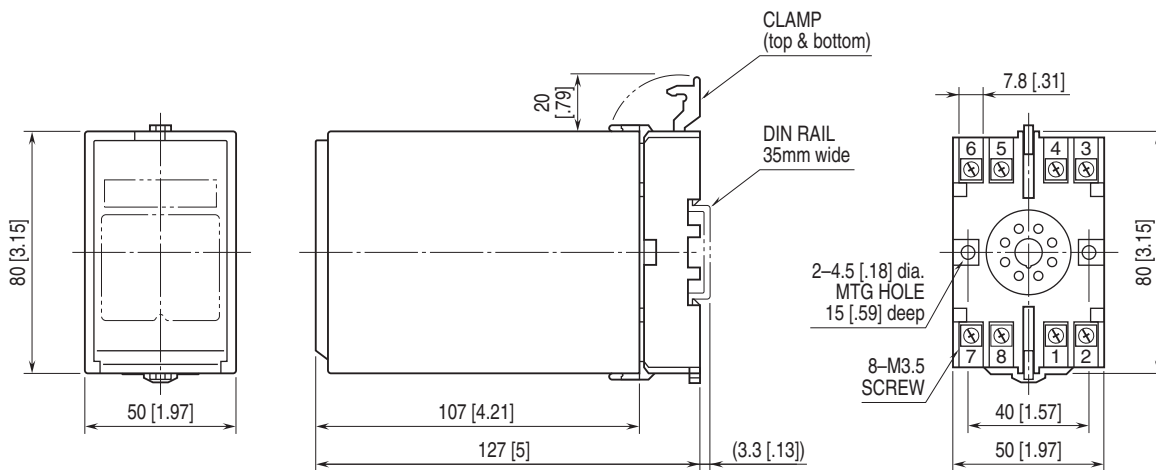

• When mounting, no extra space is needed between units.

## TERMINAL ASSIGNMENTS unit: mm [inch]

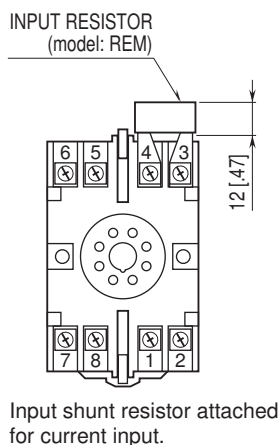

## SCHEMATIC CIRCUITRY & CONNECTION DIAGRAM

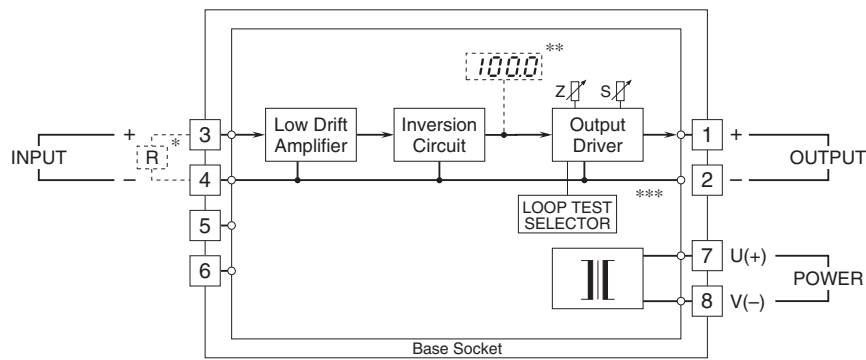

\* Input shunt resistor attached for current input.

\*\* Option /E, E2

\*\*\* Option /E2



Specifications are subject to change without notice.