

## Wireless I/O WL40VN Series

### WIRELESS GATEWAY

(Modbus/TCP, Modbus-RTU Transparent 920MHz Band Wireless Device (parent device) for Vietnam)

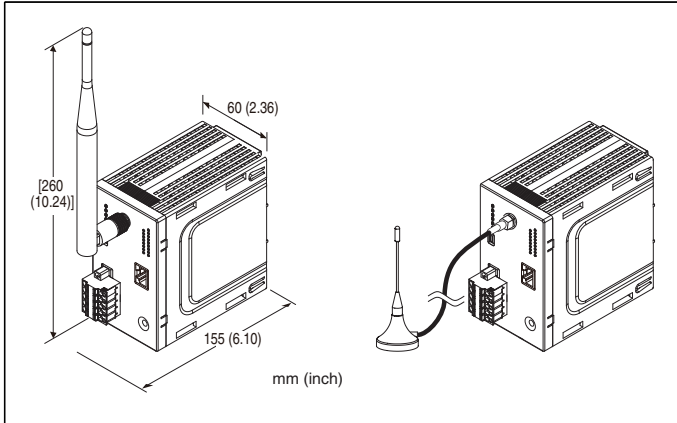

### MODEL: WL40EW2VN-[1][2]

#### ORDERING INFORMATION

- Code number: WL40EW2VN-[1][2]  
Specify a code from below for each of [1] and [2].  
(e.g. WL40EW2VN-R/E/Q)
- Specify the specification for option code /Q  
(e.g. /C01)

#### [1] POWER INPUT

DC Power  
**S:** 12 V DC  
 (Operational voltage range 12 V  $\pm$ 10 %, ripple 10 %p-p max.)  
**R:** 24 V DC  
 (Operational voltage range 24 V  $\pm$ 10 %, ripple 10 %p-p max.)

#### [2] OPTIONS (multiple selections)

Antenna  
**/S:** Sleeve antenna  
**/E:** Rooftop antenna  
 Other Options  
**blank:** none  
**/Q:** Option other than the above (specify the specification)

#### SPECIFICATIONS OF OPTION: Q

COATING (For the detail, refer to our web site.)  
**/C01:** Silicone coating  
**/C02:** Polyurethane coating  
**/C03:** Rubber coating

#### FUNCTIONS & FEATURES

This unit

- Incorporates 920MHz band wireless module with RS-485 transparent type, which can communicate using Modbus-RTU protocol.
- Converts Modbus-RTU (RS-485) and Modbus/TCP (Ethernet) protocol.

For use in Vietnam only.

#### RELATED PRODUCTS

For related products of wireless device, refer to our web site.

##### Maintenance software

**Maintenance console:** MH920 Console International (model: MH920CI) (OKI)  
 (Maintenance software is downloadable at our web site.)

##### Coaxial cable

- 7.5 m extension cable for rooftop antenna (model: CX-SAC0SAD0Q0750) (OKI)

Using 7.5 m coaxial cable for extension decreases transmission distance.

#### GENERAL SPECIFICATIONS

##### Connection

**Wireless network:** SMA coaxial connector  
**Power supply:** Tension clamp (Front Twinconnection)  
**Applicable wire size:** 0.2 - 2.5 mm<sup>2</sup>, stripped length 10 mm  
**Ethernet:** RJ-45 Modular Jack  
**Maintenance:** Mini USB type B female connector  
**Housing material:** Flame-resistant resin  
**Isolation:** Power supply to Ethernet or FE1 to antenna connector  
**Switch:** IP Reset  
 Refer to the instruction manual for details.  
**Indicator LED:** Power

## COMMUNICATION

### ■ Common spec.

Modbus protocol

**Protocol:** Modbus/TCP

**Data:** RTU (Binary)

**Port No.:** 502

**Max. number of socket connections:** 8

**IP address:** 192.168.0.1

(factory setting; can be changed via web browser)

### ■ Ethernet

**Communication Standard:** IEEE 802.3u

**Transmission:** 10BASE-T, 100BASE-TX

**Baud rate:** 10/100 Mbps (Auto Negotiation function)

**Transmission media:** 10BASE-T (STP, Category 5) 100BASE-TX (STP, Category 5e)

**Max. length of fieldbus segment:** 100 meters

**Ethernet indicator LED:** Link, Link100

## WIRELESS SPECIFICATIONS

**Communication Standard:** IEEE 802.15.4g

**Frequency:** 920MHz band (918.9 - 922.5 MHz)

**Max. Transmission power:** 20mW

**Modulation:** GFSK

**Baud rate:** Max. 100 kbps

**Channels:** 2 to 7ch

**Security:** 128bit AES

**Indicator LEDs:** 920Run, 920Link

**Number of child devices:** Max. 100

**Protocol:** Modbus-RTU

**Communication module:** Coordinator module incorporated (Oki Electric Industry Co., Ltd. )

**Radio parameters setting:** by Web browser

**Max. transmission distance (optical):** Approx. 1 km

### Antenna

- Sleeve antenna (Model: MH920-ANT-F (S))

Indoor use

Non-waterproof

Non-directional

Gain: 3.0dBi max.

- Rooftop antenna (Model: MH920-ANT-F (R))

Outdoor/indoor use

Cable length: 2.5 m

Waterproof performance: IPx6 (except connector)

Non-directional

Gain: 2.0dBi max.

## INSTALLATION

**Current consumption:**

24 V DC: ≤ 90 mA

12 V DC: ≤ 170 mA

**Operating temperature:** -20 to +60°C (-4 to +140°F)

**Operating humidity:** 10 to 90 %RH (non-condensing)

**Atmosphere:** No corrosive gas or heavy dust

**Mounting:** DIN rail

### Weight

**Unit:** Approx. 270 g (0.60 lb)

**Sleeve antenna (standard):** 27 g (0.95 oz)

**Rooftop antenna:** 52 g (1.83 oz)

## PERFORMANCE

**Insulation resistance:** ≥ 100 MΩ with 500 V DC

**Dielectric strength:** 1500 V AC @ 1 minute

(power input to Ethernet or FE1 to antenna connector)

## STANDARDS & APPROVALS

QCVN 47: 2015 / BTTTT

QCVN 96: 2015 / BTTTT

## WEB BROWSER SETTING

With Web browser, settings shown below are available.

Refer to the operating manual (EM-9115-B) for detailed settings.

### ■ TCP / IP SETTING

ITEM	SETTING RANGE	DEFAULT
IP address	1.0.0.0 – 223.255.255.255	192.168.0.1
Subnet mask	224.0.0.0 – 255.255.255.255	255.255.255.0
Default gateway	0.0.0.0 – 255.255.255.255	0.0.0.0

### ■ MODBUS / TCP SETTING

ITEM	SETTING RANGE	DEFAULT
Port	1 – 65535	502
Modbus exception response	Not return 06 (BUSY), 0B (ERROR) / Return 06 (BUSY), 0B (ERROR)	Return 06 (BUSY), 0B (ERROR)
Communication timeout	1 – 60 (min.)	1 (min.)

### ■ WIRELESS SETTING

ITEM	SETTING RANGE	DEFAULT
PAN ID (group number)	0000 – FFFE (hexadecimal, 4 digits)	0000
Radio channel number	2 – 7 ch	2 ch
Network name	English one-byte characters within 16 characters (one-byte space, “-”, “_”, “:”, “@” are usable.)	MH920
Encryption key	0000...0 – FFFF..F (hexadecimal, 32 digits)	0000...0
Prefix	2000:0000:0000:0000 – 3FFF:FFFF:FFFF:FFFF	2000:0000:0000:0000
Monitoring unit time of 1% duty (sec.)	10 – 3600 (sec.)	1800 (sec.)
Transmitter power output	0.16mW / 1mW / 20mW	20mW
Device type in a network, Number of devices in a network	Child (fixed), 1 to 30 devices / Child (fixed), 31 to 60 devices / Child (fixed), 61 to 100 devices / Child (fixed) + child (moving)	Child (fixed), 1 to 30 devices
Set network quality	Standard (recommended) / Frequency of route switching and delay (higher) / Frequency of route switching and delay (highest)	Standard (recommended)
Network join mode	V3-compatible mode / Fast join mode	V3-compatible mode
Packet filtering	None / Yes (polling type)	Yes (polling type)
Filter timeout on polling	1.0 – 60.0 (sec.)	4.0 (sec.)
Setting mode of short address	Range mode: 1 device (max. multi drop number) Range mode: 1 to 4 devices (max. multi drop number) Range mode: 1 to 8 devices (max. multi drop number) Range mode: 1 to 16 devices (max. multi drop number) Range mode: 1 to 31 devices (max. multi drop number) List mode	List mode
920Run timeout	0.0 – 3200.0 (sec.)	5.0 (sec.)
Retry times before route switching	Once / Twice / Three times	Three times
Short address list setting	Short address	—
MAC address list setting	MAC address	—
Connection refusal list setting	MAC address	—

Note: For version confirmation of communication module, refer to the operating manual (EM-9115-B).

## EXTERNAL VIEW

### FRONT VIEW

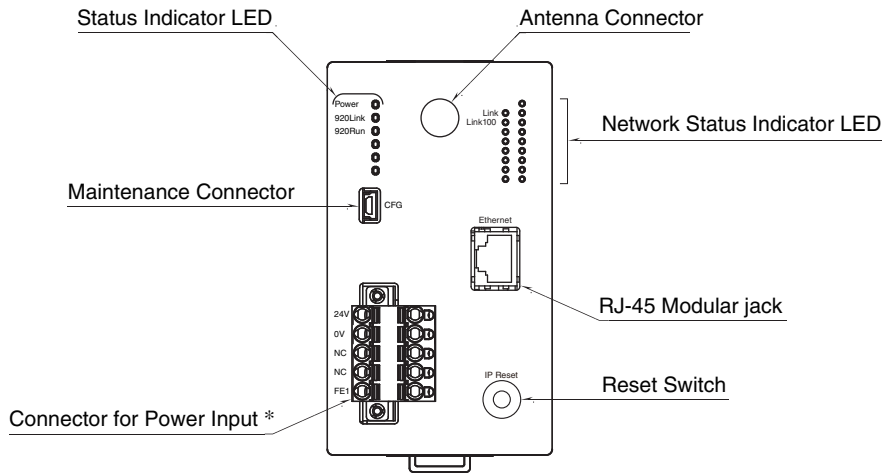

\* Power input defers depending on the power input code you select.

## TERMINAL ASSIGNMENTS

### CONNECTORS FOR POWER INPUT

Unit side connector: MSTBV2,5/5-GF-5,08AU (Phoenix Contact)

Cable side connector: TFKC2,5/5-STF-5,08AU (Phoenix Contact)

#### Power input code: R (24 V DC)

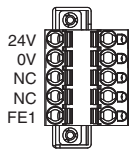

ID	FUNCTION
24V	Power input 24 V
0V	Power input 0 V
NC	Not used
NC	Not used
FE1	Power input earth

#### Power input code: S (12 V DC)

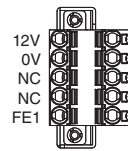

ID	FUNCTION
12V	Power input 12 V
0V	Power input 0 V
NC	Not used
NC	Not used
FE1	Power input earth

## MODBUS FUNCTION CODES & SUPPORTED CODES

Modbus function codes are shown below.

### DATA AND CONTROL FUNCTIONS

CODE	NAME	
01	Read Coil Status	Digital output from the slave (read/write)
02	Read Input Status	Status of digital inputs to the slave (read only)
03	Read Holding Registers	General purpose register within the slave (read/write)
04	Read Input Registers	Collected data from the field by the slave (read only)
05	Force Single Coil	Digital output from the slave (read/write)
06	Preset Single Register	General purpose register within the slave (read/write)
15	Force Multiple Coils	Digital output from the slave (read/write)
16	Preset Multiple Registers	General purpose register within the slave (read/write)

### EXCEPTION CODES

CODE	NAME	
06	Slave Device Busy	Device's Modbus/TCP request queue is full.
11	Gateway Target Device Failed To Respond	Response from 920MHz band wireless device (child) is error, or response timeout occurred.

Note: When 920 MHz band wireless device (child) returns an exception code other than the above, the exception code is directly transmitted to upper devices.

## EXTERNAL DIMENSIONS unit: mm [inch]

### • With sleeve antenna

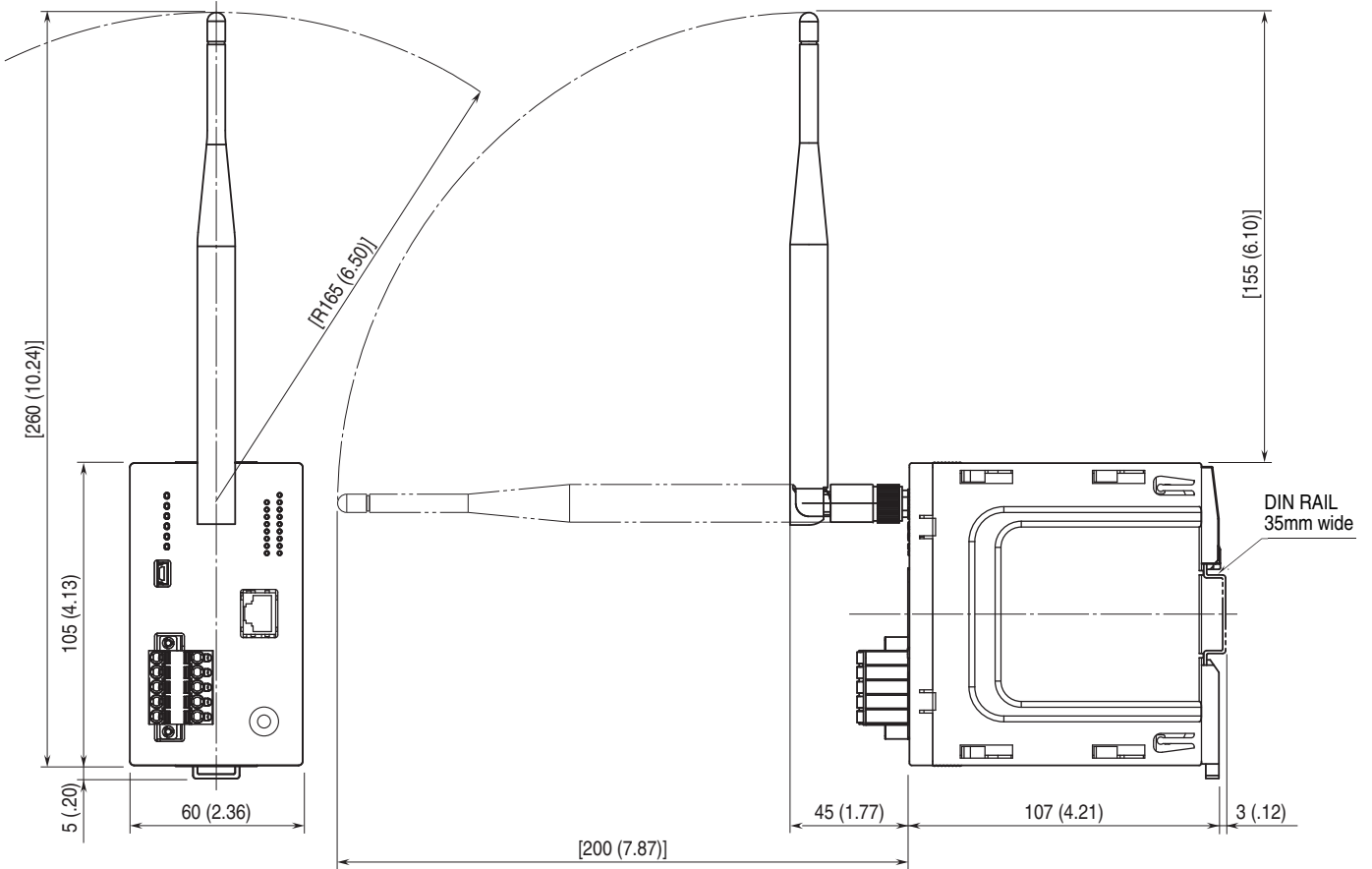

### • With rooftop antenna

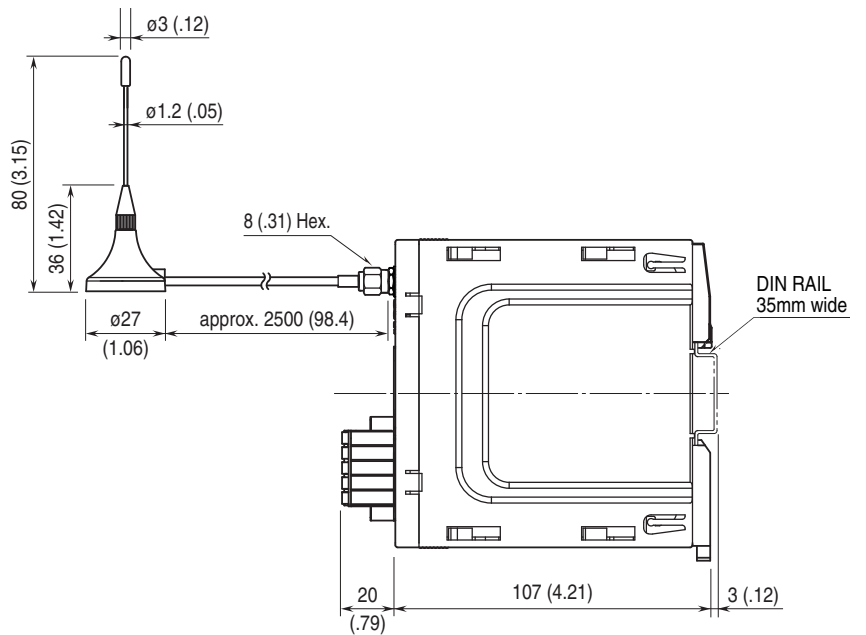

## SCHEMATIC CIRCUITRY & CONNECTION DIAGRAM

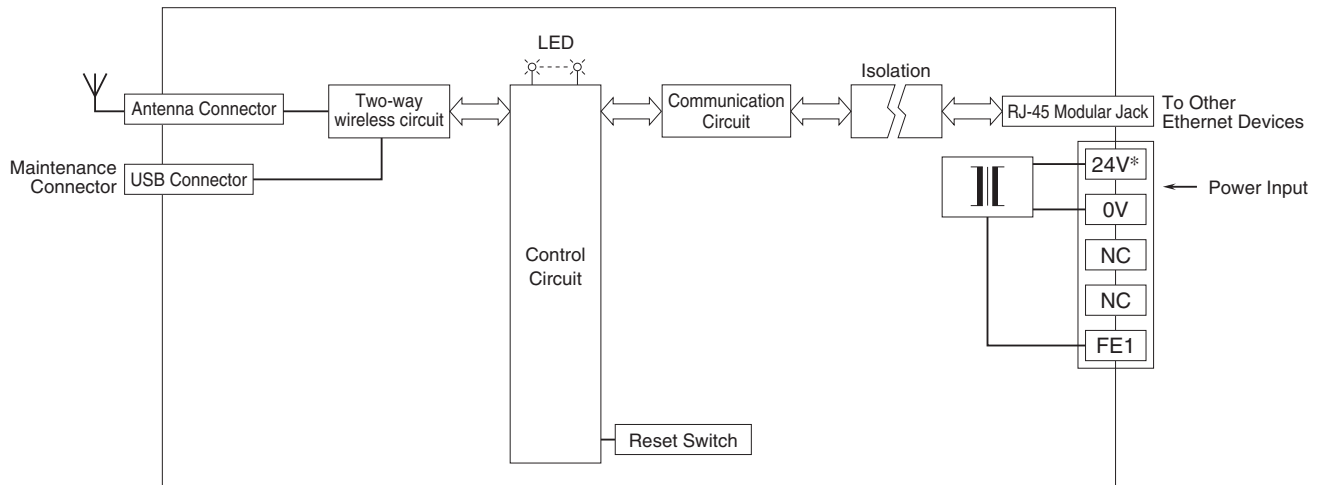

\* Power input defers depending on the power input code you select.

## SYSTEM CONFIGURATION EXAMPLES

PC side as Modbus/Master communicates with child devices via wireless module using Modbus/TCP and RTU protocol, and also communicates with slave devices in multi drop connection (RS-485).

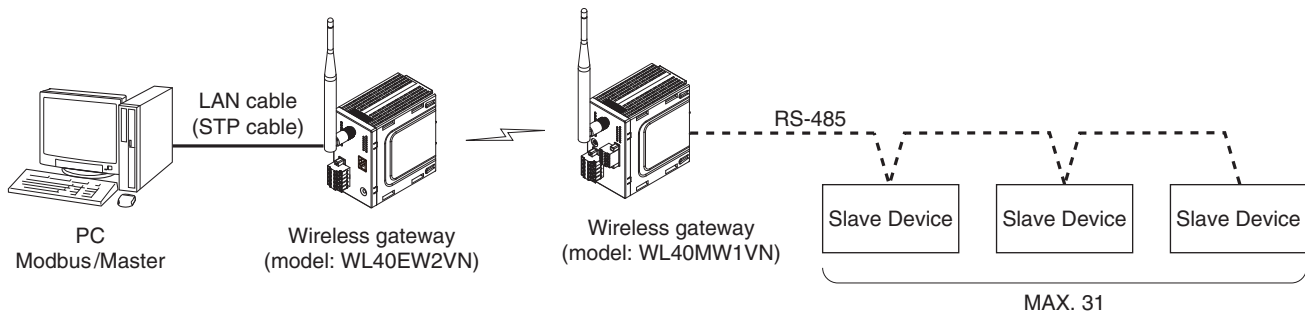

Specifications are subject to change without notice.