

Remote I/O R8 Series

(Operational voltage range: $\pm 10\%$; ripple 10 %p-p max.)

R8 SERIES GENERAL SPECIFICATIONS

Functions & Features

- Remote I/O modules which interchange analog or digital I/O signals with the fieldbus
- Space-saving

Typical Applications

- Remote I/O for DCS and PLC
- Personal computer I/O

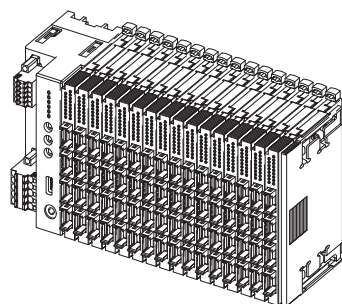

I/O MODULE: R8-[1]

Refer to the specifications for the respective models.

[1] MODULE TYPE

- Analog Input
 - SS2:** DC current input, (isolated), 2 points
 - SS4NJ:** DC current input (built-in excitation, non-isolated), 4 points
 - SS4N:** DC current input (non-isolated), 4 points
 - SST8:** DC current input (isolated), 8 points
 - SV2:** DC voltage input (isolated), 2 points
 - SV4N:** DC voltage input (non-isolated), 4 points
 - SVT8:** DC voltage input (isolated), 8 points
 - TS2:** Thermocouple input (isolated), 2 points
 - RS4N:** RTD input (non-isolated), 4 points
 - FS16N:** DC current/voltage input (built-in excitation, non-isolated), 16points
 - FST4N:** DC current/voltage input (built-in excitation, non-isolated), 4points
 - CT4E:** AC current input (RMS sensing, clamp-on current sensor, non-isolated), 4 points
- Analog Output
 - YS2:** DC current output (isolated), 2 points
 - YS2NJ:** DC current output (built-in excitation, non-isolated), 2 points
 - YST4N:** DC current output (non-isolated), 4 points
 - YV4N:** DC voltage output (non-isolated), 4 points
 - YVM4N:** DC voltage output (non-isolated), 4 points
 - YVT4N:** DC voltage output (non-isolated), 4 points
- Pulse Input
 - PA4:** Totalized pulse input, 4 points
 - PA4F:** High-speed totalized pulse input, 4 points
- Pulse Output
 - PC4A:** Open collector output, 4 points
- Discrete Input
 - DA4A:** Discrete input, 4 points
 - DAM16A:** Discrete input (NPN), 16 points
 - DAT8A2:** Discrete input (NPN), 8 points
 - DAT8B2:** Discrete input (PNP), 8 points
 - DAT16A2:** Discrete input (NPN), 16 points
 - DAT16B2:** Discrete input (PNP), 16 points
- Discrete Output
 - DC4A:** Discrete output (NPN), 4 points
 - DC4A2:** Discrete output (NPN), 4 points
 - DC4C:** Photo MOSFET relay output, 4 points
 - DCT4D:** Relay output, 4 points
 - DCM16A:** Discrete output (NPN), 16 points
 - DCM16ALZ:** Discrete output (NPN) with full interlock, 16 points
 - DCM16ALK:** Discrete output (NPN) with full and individual interlock, 16 points

ORDERING INFORMATION

- Power/Network module: R8-[1]-R
Specify a code from below for [1].
(e.g. R8-NM1-R)
- I/O module: R8-[1]
Specify a code from below for [1].
(e.g. R8-DA4A)
- Extension power supply module: R8-[1]-R
Specify a code from below for [1].
(e.g. R8-PS1-R)

POWER/NETWORK MODULE: R8-[1]-R

Refer to the specifications for the respective models.

[1] MODULE TYPE

- ND1:** DeviceNet
- ND2:** DeviceNet
- NM1:** Modbus
- NECT1:** EtherCAT
- NEIP1:** EtherNet/IP
- NC3:** CC-Link
- NC3A:** CC-Link

POWER INPUT

- DC power
- R:** 24 V DC

DCM16ALH: Discrete output (NPN) with full and partial interlock, 16 points

DCM32B2: Discrete output (PNP), 32 points

DCT8A2: Discrete output (NPN), 8 points

DCT8B2: Discrete output (PNP), 8 points

DCT16A2: Discrete output (NPN), 16 points

DCT16B2: Discrete output (PNP), 16 points

- Temperature Control

TC2: Temperature Control Module

Since internal power supply source and internal communication bus are performed through the connector of each module, installation base is unnecessary.

EXTENSION POWER SUPPLY MODULE: R8-[1]-R

Refer to the specifications for the respective models.

[1] MODULE TYPE

PS1: Extension power supply module

POWER INPUT

- DC power

R: 24 V DC

(Operational voltage range: $\pm 10\%$; ripple 10 %p-p max.)

FUNCTIONS & FEATURES

The R8 Series Remote I/O is composed of power/network modules, I/O modules and extension power supply module.

■ I/O MODULE

Performs data conversion of field inputs; Data conversion of data received through the internal bus into outputs.

■ POWER/NETWORK MODULE

The power/network module supplies the I/O modules with required internal electrical power source.

The power/network module changes the receiving data from internal bus into output signal and vice versa, acts as a gateway between transmission line and internal bus.

■ EXTENSION POWER SUPPLY MODULE

Inserted between I/O modules and supply the power when output current of power/network module is insufficient.

■ DATA CONVERSION

Depends upon the type of module and ranges.

For analog input module, 0 to 100 % of the selected range is converted into 0 to 10000 (dec) or 0000 to 2710 (hex). -5 to 0 % is represented in 2's complements.

Analog output is represented with 16-bit binary data. 0 to 10000 (dec) or 0000 to 2710 (hex)

is converted into 0 to 100 % of the selected range.

-5 to 0 % is represented in 2's complements.

For RTD, thermocouple input module at factory setting, data

is represented with 16-bit signed binary data of engineering unit value ($^{\circ}\text{C}$) multiplied by 10. e.g. In case of measuring 27.5°C , value is 275.

Refer to each model manual for details.

■ SCALING & ZERO & SPAN ADJUSTMENTS

The PC Configurator Software (model: R8CFG) is available to scale 0 to 100 % data. It is available to configure in the range between -32000 and 32000. e.g. Configuring temperature range by Configurator Software enables to handle 100 to 200°C as value 0 to 10000.

■ HOT INSERTION/REMOVAL OF I/O MODULES

Since internal power supply and internal bus are performed through the connector of each module, it cannot be replaced with the power on.

■ DIELECTRIC STRENGTH

As dielectric strength differs depending on each module, refer to each specification sheet.

RELATED PRODUCTS

- PC configurator software (model: R8CFG)

Downloadable at our web site.

A dedicated cable is required to connect the module to the PC. Please refer to the internet software download site or the users manual for the PC configurator for applicable cable types.

GENERAL SPECIFICATIONS

Power input:

- R8-NM1-R
- R8-NECT1-R
- R8-NEIP1-R
- R8-ND1-R
- R8-ND2-R
- R8-NC3-R
- R8-NC3A-R
- R8-PS1-R:

24 V DC $\pm 10\%$; ripple 10 %p-p max.

Power consumption

- **DC:** Approx. 12 W (Approx. 11 W for R8-PS1-R)
- 24 V DC (@ output current 1.6 A)

Internal power

- **DC:** 5 V DC
- **Operational current:** 1.6 A

Excitation supply output

- **DC:** 24 V DC $\pm 10\%$
- **Operational current:** 10 A (8 A for R8-PS1-R)
- (Power output current consumption must be under rated current)

Operating temperature: -10 to $+55^{\circ}\text{C}$ (14 to 131°F)

R8-NC3, R8-NC3A: 0 to 55°C (32 to 131°F)

Operating humidity: 30 to 90 %RH (non-condensing)

Atmosphere: No corrosive gas or heavy dust

Mounting: DIN rail (35 mm wide)

Connection

•Power/network module

•Power supply, exc. supply:

Tension clamp style: Front Twin Connection

Applicable wire size: 0.2 to 2.5 mm², stripped length 10 mm

•Modbus:

Tension clamp style: Front Twin Connection

Applicable wire size: 0.2 to 1.5 mm², stripped length 10 mm

•EtherCAT: RJ-45 connector

•DeviceNet:

Tension clamp style: Front Twin Connection

Communication cable: Cable to meet the DeviceNet specification, Stripped length 10 mm

•CC-Link:

Tension clamp style: Front Twin Connection

Communication cable: Cable to meet the CC-Link specification, Stripped length 10 mm

•I/O module:

Connection

•4 pin e-CON connector

Unit side connector XN2D-1474-S002 (Omron)

Recommended cable side connector XN2A-1470 (Omron)*¹

Applicable wire size: 0.08 mm² (AWG28) - 0.5 mm² (AWG20)
(Outer sheath diameter: max. 1.5 dia)

•20 pin MIL connector

Unit side connector XG4A-2034 (Omron), our product

Recommended cable side socket XG5N-201 (Omron)*¹

Recommended cable side contact XG5W-0231 (Omron)*¹

Applicable wire size: AWG22, number of conductor 17,
diameter of conductor 0.16 mm

*1. Not included in the package. Refer to the specifications of the product.

•40 pin MIL connector

Unit side connector XG4A-4034 (Omron), our product

Recommended cable side socket XG5N-401 (Omron)*¹

Recommended cable side contact XG5W-0231 (Omron)*¹

Applicable wire size: AWG22, number of conductor 17,
diameter of conductor 0.16 mm

*1. Not included in the package. Refer to the specifications of the product.

•Extension power supply module:

Tension clamp style: Front Twin Connection

Applicable wire size: 0.2 to 1.5 mm², stripped length 10 mm

Housing material: Flame-resistant resin (black)

Max. number of I/O modules: 16 (module address: 0 to 31)

Internal communication bus: Transmission cycle approx.
250 μsec / Module address

■ WEIGHT

| | |
|-------------------|----------------|
| R8-NM1: | 160g (0.35 lb) |
| R8-NECT1: | 180g (0.40 lb) |
| R8-NEIP1: | 180g (0.40 lb) |
| R8-ND1: | 180g (0.40 lb) |
| R8-ND2: | 180g (0.40 lb) |
| R8-NC3: | 180g (0.40 lb) |
| R8-NC3A: | 180g (0.40 lb) |
| R8-CT4E: | 65g (2.30 oz) |
| R8-DA4A: | 60g (2.12 oz) |
| R8-DAM16A: | 65g (2.30 oz) |
| R8-DAT8A2: | 110g (0.24 lb) |
| R8-DAT8B2: | 110g (0.24 lb) |
| R8-DAT16A2: | 110g (0.24 lb) |
| R8-DAT16B2: | 110g (0.24 lb) |
| R8-DC4A: | 60g (2.12 oz) |
| R8-DC4A2: | 60g (2.12 oz) |
| R8-DC4C: | 60g (2.12 oz) |
| R8-DCT4D: | 120g (0.26 lb) |
| R8-DCM16A: | 65g (2.30 oz) |
| R8-DCM16ALZ: | 110g (0.24 lb) |
| R8-DCM16ALK: | 110g (0.24 lb) |
| R8-DCM16ALH: | 110g (0.24 lb) |
| R8-DCM32B2: | 110g (0.24 lb) |
| R8-DCT8A2: | 110g (0.24 lb) |
| R8-DCT8B2: | 110g (0.24 lb) |
| R8-DCT16A2: | 110g (0.24 lb) |
| R8-DCT16B2: | 110g (0.24 lb) |
| R8-FS16N: | 110g (0.24 lb) |
| R8-FST4N: | 80g (0.18 lb) |
| R8-PA4: | 60g (2.12 oz) |
| R8-PA4F: | 60g (2.12 oz) |
| R8-PC4A: | 60g (2.12 oz) |
| R8-PS1: | 100g (0.22 lb) |
| R8-RS4N: | 60g (2.12 oz) |
| R8-SS2: | 60g (2.12 oz) |
| R8-SS4N: | 60g (2.12 oz) |
| R8-SS4NJ: | 60g (2.12 oz) |
| R8-SST8: | 100g (0.22 lb) |
| R8-SV2: | 60g (2.12 oz) |
| R8-SV4N: | 60g (2.12 oz) |
| R8-SVT8: | 100g (0.22 lb) |
| R8-TC2: | 110g (0.24 lb) |
| R8-TS2: | 60g (2.12 oz) |
| R8-YS2: | 110g (0.24 lb) |
| R8-YS2NJ: | 60g (2.12 oz) |
| R8-YST4N: | 120g (0.26 lb) |
| R8-YV4N: | 60g (2.12 oz) |
| R8-YVM4N: | 70g (2.47 oz) |
| R8-YVT4N: | 70g (2.47 oz) |
| Protective cover: | 15g (0.53 oz) |

■ DATA ALLOCATION

| | |
|----------------|----------------|
| R8-CT4E: 2 | R8-DCT4D: 1 |
| R8-DA4A: 1 | R8-DCM16A: 1 |
| R8-DAM16A: 1 | R8-DCM16ALZ: 1 |
| R8-DAT8A2: 1 | R8-DCM16ALK: 1 |
| R8-DAT8B2: 1 | R8-DCM16ALH: 1 |
| R8-DAT16A2: 1 | R8-DCM32B2: 2 |
| R8-DAT16B2: 1 | R8-DCT8A2: 1 |
| R8-DC4A: 1 | R8-DCT8B2: 1 |
| R8-DC4A2: 1 | R8-DCT16A2: 1 |
| R8-DC4C: 1 | R8-DCT16B2: 1 |
| R8-DCT4D: 1 | R8-FS16N: 8 |
| R8-DCM16A: 1 | R8-FST4N: 2 |
| R8-DCM16ALZ: 1 | R8-PA4: 4 |
| R8-DCM16ALK: 1 | R8-PA4F: 4 |
| R8-DCM16ALH: 1 | R8-PC4A: 2 |
| R8-DCM32B2: 1 | R8-RS4N: 2 |
| R8-DCT8A2: 1 | R8-SS2: 1 |
| R8-DCT8B2: 1 | R8-SS4N: 2 |
| R8-DCT16A2: 1 | R8-SS4NJ: 2 |
| R8-DCT16B2: 1 | R8-SST8: 4 |
| R8-FS16N: 2 | R8-SV2: 1 |
| R8-FST4N: 2 | R8-SV4N: 2 |
| R8-PA4: 2 | R8-SVT8: 4 |
| R8-PA4F: 2 | R8-TC2: 8 |
| R8-PC4A: 2 | R8-TS2: 1 |
| R8-RS4N: 2 | R8-YS2: 1 |
| R8-SS2: 2 | R8-YS2NJ: 1 |
| R8-SS4N: 2 | R8-YST4N: 2 |
| R8-SS4NJ: 2 | R8-YV4N: 2 |
| R8-SST8: 2 | R8-YVM4N: 2 |
| R8-SV2: 2 | R8-YVT4N: 2 |
| R8-SV4N: 2 | |
| R8-SVT8: 2 | |
| R8-TC2: 2 | |
| R8-TS2: 2 | |
| R8-YS2: 2 | |
| R8-YS2NJ: 2 | |
| R8-YST4N: 2 | |
| R8-YV4N: 2 | |
| R8-YVM4N: 2 | |
| R8-YVT4N: 2 | |

■ ADDRESSES IN USE

| |
|---------------|
| R8-CT4E: 2 |
| R8-DA4A: 1 |
| R8-DAM16A: 1 |
| R8-DAT8A2: 1 |
| R8-DAT8B2: 1 |
| R8-DAT16A2: 1 |
| R8-DAT16B2: 1 |
| R8-DC4A: 1 |
| R8-DC4A2: 1 |
| R8-DC4C: 1 |

STANDARDS & APPROVALS

EU conformity:

EMC Directive
 EMI EN 61000-6-4
 EMS EN 61000-6-2
 RoHS Directive

CURRENT CONSUMPTION

The I/O modules operate by the DC voltage (5 V DC) supplied from the power/network module. Arrange these modules in order that the total current consumed by these modules be within the supply current capacity. If the current consumption exceeds the limit, insert an extension power supply module. Even if total consumption current of the I/O modules is less than the supply current capacity, the total install number of the modules is max. 16. (Except extension power supply module)

■ Max. current consumption

R8-CT4E: 100 mA
 R8-DA4A: 80 mA
 R8-DAM16A: 100 mA
 R8-DAT8A2: 100 mA
 R8-DAT8B2: 100 mA
 R8-DAT16A2: 100 mA
 R8-DAT16B2: 100 mA
 R8-DC4A: 100 mA
 R8-DC4A2: 100 mA
 R8-DC4C: 120 mA
 R8-DCT4D: 100 mA
 R8-DCM16A: 110 mA
 R8-DCM16ALZ: 160 mA
 R8-DCM16ALK: 160 mA
 R8-DCM16ALH: 160 mA
 R8-DCM32B2: 110 mA
 R8-DCT8A2: 110 mA
 R8-DCT8B2: 110 mA
 R8-DCT16A2: 110 mA
 R8-DCT16B2: 110 mA
 R8-FS16N: 100 mA
 R8-FST4N: 100 mA
 R8-PA4: 80 mA
 R8-PA4F: 90 mA
 R8-PC4A: 100 mA
 R8-RS4N: 100 mA
 R8-SS2: 100 mA
 R8-SS4N: 80 mA
 R8-SS4NJ: 80 mA
 R8-SST8: 200 mA
 R8-SV2: 100 mA
 R8-SV4N: 80 mA
 R8-SVT8: 200 mA
 R8-TC2: 200mA
 R8-TS2: 100 mA
 R8-YS2: 80 mA
 R8-YS2NJ: 70 mA
 R8-YST4N: 70 mA
 R8-YV4N: 160 mA
 R8-YVM4N: 160 mA
 R8-YVT4N: 160 mA

| MODEL | EXC. SUPPLY | OPERATION AT ONLY EXC. SUPPLY CUT OFF |
|-------------|-------------|---|
| R8-SS2 | — | Normal operation continued |
| R8-SS4NJ | ✓ | Exc. supply OFF, input normal operation continued |
| R8-SS4N | — | Normal operation continued |
| R8-SST8 | — | Normal operation continued |
| R8-SV2 | — | Normal operation continued |
| R8-SV4N | — | Normal operation continued |
| R8-SVT8 | — | Normal operation continued |
| R8-TS2 | — | Normal operation continued |
| R8-RS4N | — | Normal operation continued |
| R8-CT4E | — | Normal operation continued |
| R8-YS2 | ✓ | Output 0 mA DC |
| R8-YS2NJ | ✓ | Exc. supply OFF, output 0mA DC |
| R8-YST4N | ✓ | Output 0 mA DC |
| R8-YV4N | — | Normal operation continued |
| R8-YVM4N | — | Normal operation continued |
| R8-PA4 | ✓ | Input OFF, voltage pulse normal operation continued |
| R8-PA4F | ✓ | Input OFF |
| R8-PC4A | ✓ | Output OFF |
| R8-DA4A | ✓ | Input OFF |
| R8-DAM16A | ✓ | Input OFF |
| R8-DAT8A2 | ✓ | Input OFF |
| R8-DAT8B2 | ✓ | Input OFF |
| R8-DAT16A2 | ✓ | Input OFF |
| R8-DAT16B2 | ✓ | Input OFF |
| R8-DC4A2 | ✓ | Output OFF |
| R8-DC4C | — | Normal operation continued |
| R8-DCT4D | ✓ | Output OFF |
| R8-DCM16A | ✓ | Output OFF |
| R8-DCM16ALZ | ✓ | Output OFF, input OFF |
| R8-DCM16ALK | ✓ | Output OFF, input OFF |
| R8-DCM16ALH | ✓ | Output OFF, input OFF |
| R8-DCM32B2 | ✓ | Output OFF |
| R8-DCT8A2 | ✓ | Output OFF |
| R8-DCT8B2 | ✓ | Output OFF |
| R8-DCT16A2 | ✓ | Output OFF |
| R8-DCT16B2 | ✓ | Output OFF |
| R8-FS16N | ✓ | Exc. supply OFF, input normal operation continued |
| R8-FST4N | ✓ | Exc. supply OFF, input normal operation continued |
| R8-TC2 | ✓ | Output 0 mA DC or 0 V DC Input 1, 2, CT input 1, 2, normal operation continued |

‘✓’: Excitation supply is used. ‘—’: Excitation supply is not used.

■ MAXIMUM CURRENT CONSUMPTION OF EXCITATION POWER SUPPLY

For following models, power supply of output is supplied from excitation power supply.

R8-DCT4D: 40 mA
 R8-YS2: 60 mA
 R8-YS2NJ: 50 mA
 R8-YST4N: 90 mA
 R8-TC2: 60 mA

USING EXCITATION SUPPLY

Some I/O modules use excitation supply, on the other hand some I/O modules do not. When excitation supply is cut off during power supply is on, operation is as the table shown below.

COMBINATION OF I/O MODULES

■ COMBINATION WITH R8-NECT1 (EtherCAT)

When using the R8-NECT1 (EtherCAT) as a power/network module, I/O modules that can be combined are limited by the R8-NECT1 version.

Confirm the following table when adding new I/O modules. To confirm the versions of R8-NECT1, use monitoring function of PC Configurator Software (model: R8CFG).

| I/O MODULE | R8-NECT1 Ver. |
|------------|----------------|
| R8-DAT8A2 | 1.60 or higher |
| R8-DAT8B2 | |
| R8-DCT8A2 | |
| R8-DCT8B2 | |
| R8-PA4F | 1.50 or higher |
| R8-DCT16A2 | 1.40 or higher |
| R8-DCT16B2 | |
| R8-DCM32B2 | 1.30 or higher |
| R8-TC2 | 1.20 or higher |
| Others | |

Download the latest ESI file from our web site.

■ COMBINATION WITH OTHER POWER/NETWORK MODULES

When using other modules as power/network modules, I/O modules that can be combined are not limited.

BASIC CONFIGURATION

The number of I/O modules that can be mounted changes depending on power/network module. Refer to the specifications of each power/network module for details. Although Module address position can be set arbitrary, avoid from address overlap.

4-point analog I/O module takes two addresses per module. For example with the model R8-SV4N located at the module address 5, the inputs 1 and 2 are assigned to the address 5, and the inputs 3 and 4 are to the address 6. Do not assign another module to the address 6. All 4 inputs (input 1 through 4) can be used with Data Allocation 2, while only the inputs 1 and 3 can be used with Data Allocation 1. Totalize pulse input 4 points module have 4 addresses available per module. Set to allocation area 2.

For modules which use more than 2 address, set address so that end address does not exceed 31. For totalize pulse input 4 points module, address should not exceed 28. Only for rightmost module, set termination resistor to enable. Protective cover included for power/network modules.

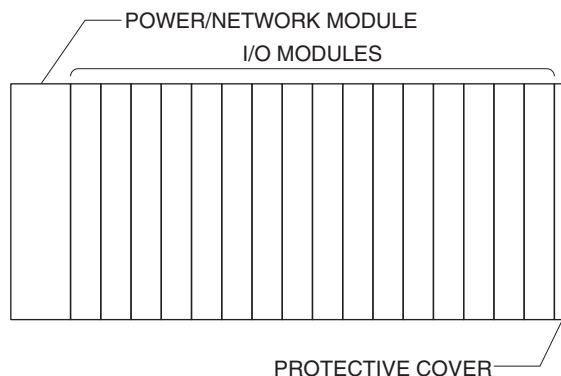

■ HOW TO MOUNT THE MODULE ON DIN RAIL

• Power/Network Module

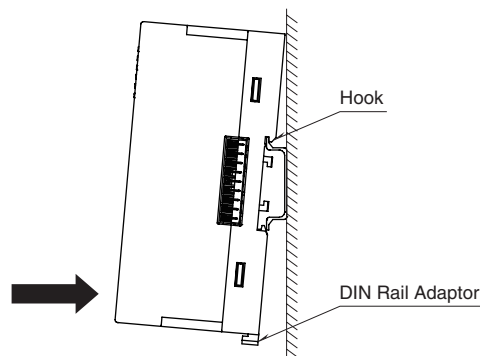

Position the upper hook at the rear on the DIN rail and push in the lower. When removing the module, push down the DIN rail adaptor utilizing a minus screwdriver and pull.

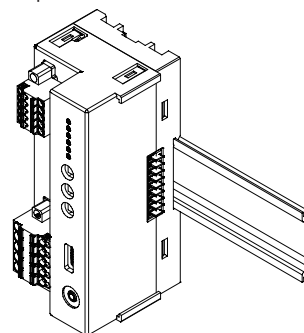

• I/O Module

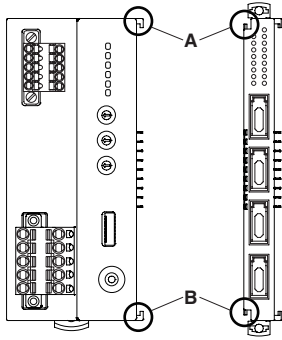

Confirm that the locking clamps of the I/O module are set.
 Insert the module in parallel to the next one while aligning the grooves of both modules (A & B in the above figure).
 Maintain it perpendicularly to the rail.

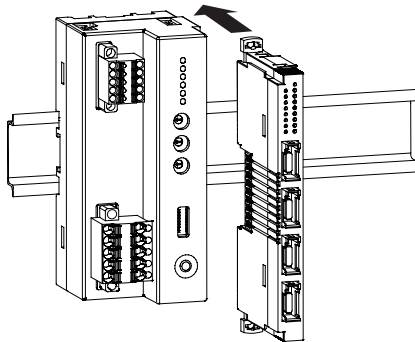

More I/O modules can be added in the same manner.

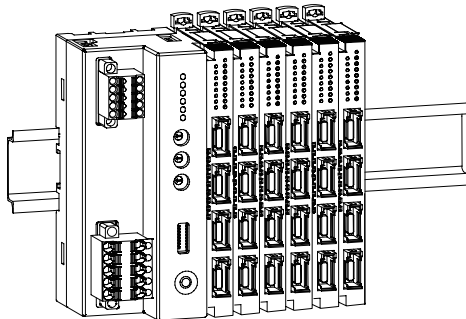

• Protective Cover

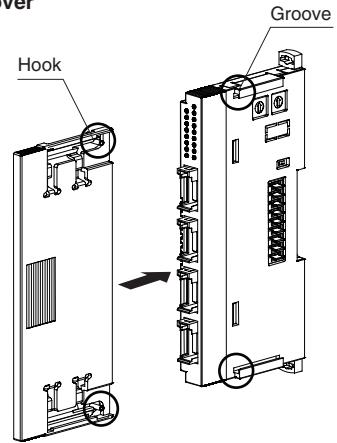

The protective cover is to be attached over the connected I/O module at the right end.
 Align the hooks on the cover with the grooves of the module and slide it straight until the hooks are latched.

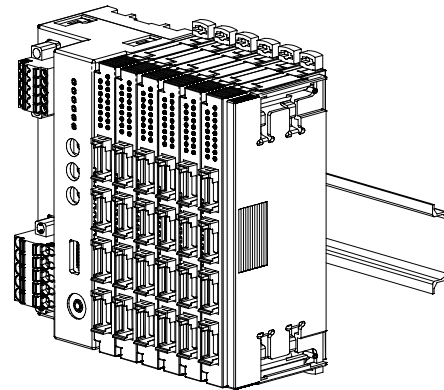

When removing the cover, pull it out while squeezing the hooks inward.

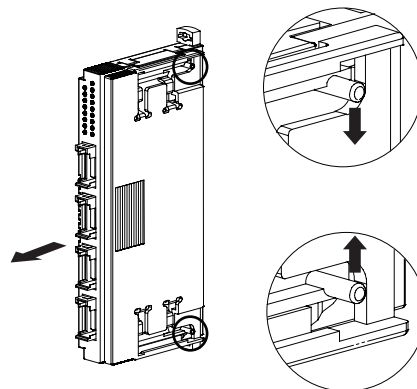

■ HOW TO UNMOUNT MODULES

Release the locking clamps and pull out straight the module.

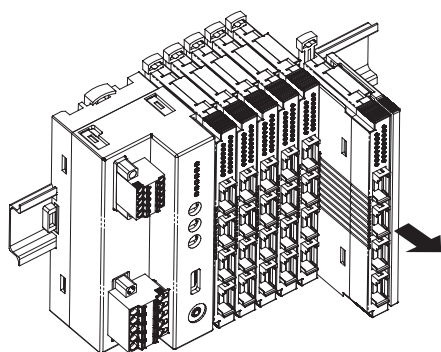
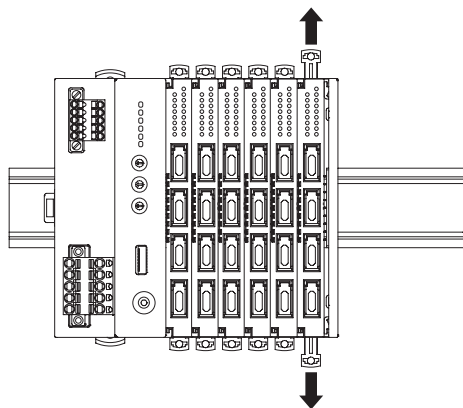

• Removing an intermediate module

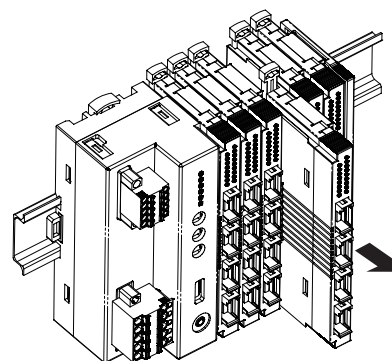
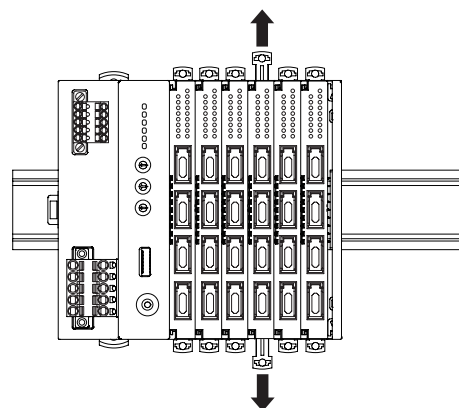

Caution !

- 1) Be careful not to hurt your hand by pointed edges of the internal bus connector.
- 2) I/O modules cannot hold tightly on the DIN rail by themselves without power/network module.
Secure them to the position if necessary by using DIN rail end plates.

MOUNTING REQUIREMENTS unit: mm (inch)

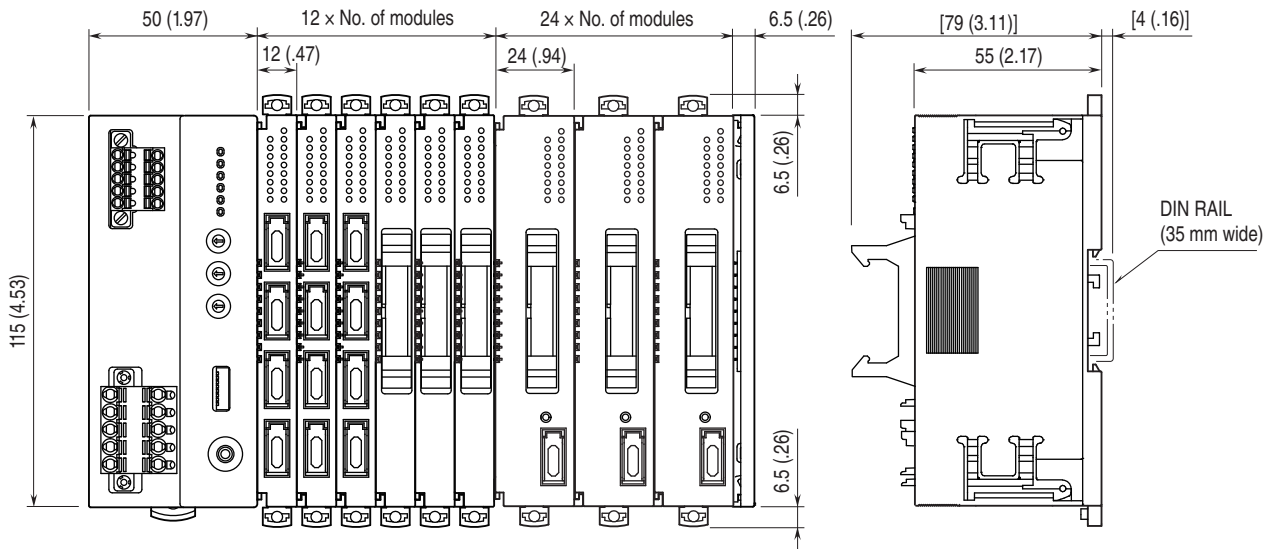

■ MOUNTING DIRECTION

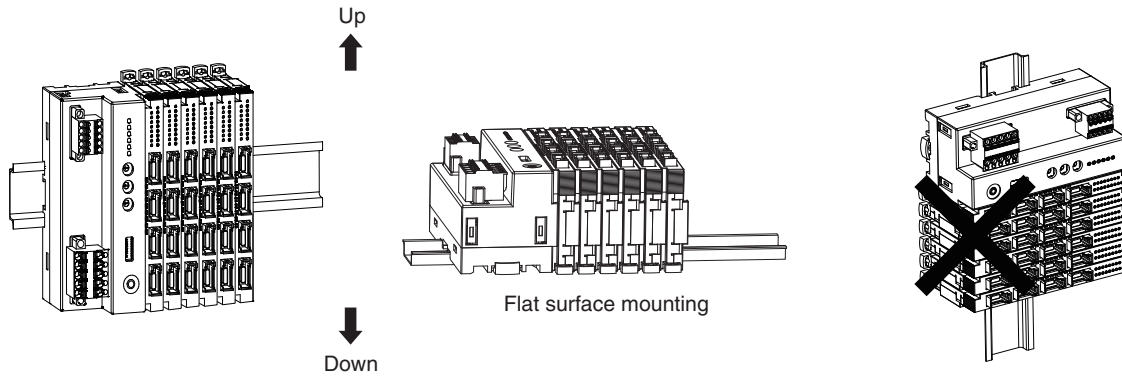

■ MOUNTING TO PANEL: mm (inch)

Leave enough space between the unit and the mounting panel.

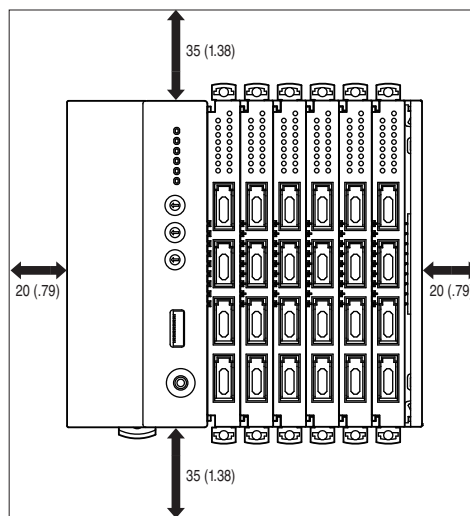

SYSTEM CONFIGURATION EXAMPLES

■ POWER/NETWORK MODULE: R8-NM1

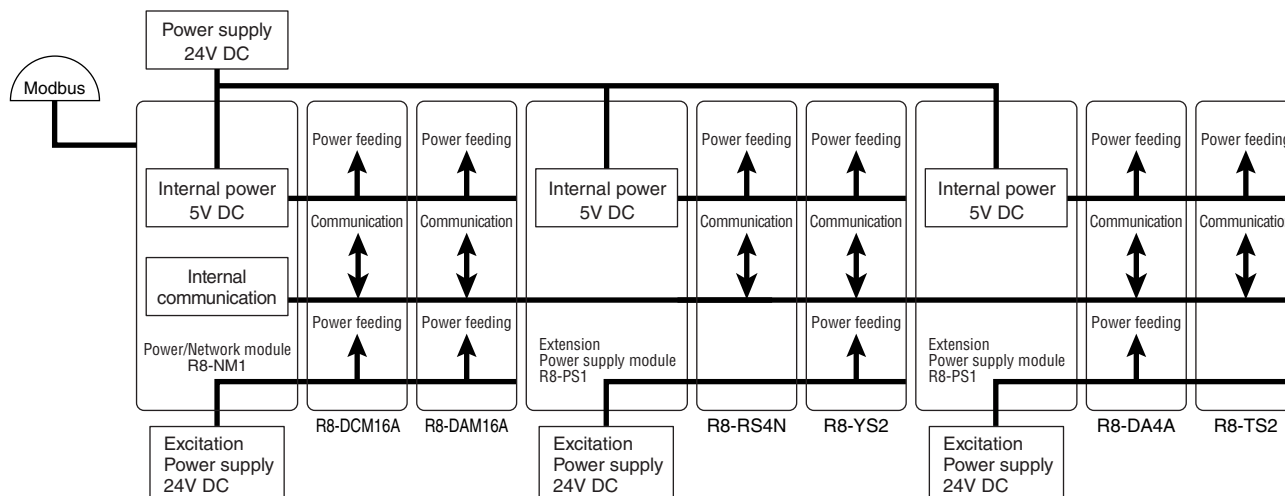

Note 1: Use same power source for Power/Network module and Extension power supply module.
 Note 2: Extension power supply module can be used up to two units at the same time.



Specifications are subject to change without notice.