

## Remote I/O R8 Series

### NPN TRANSISTOR OUTPUT MODULE, 16 points

(with shortcircuit protection, full and partial interlock)

#### Functions & Features

- 16 channels for discrete output, compact size remote I/O module
- 20 pin MIL connector
- With interlock input it is available to turn all or half of outputs off

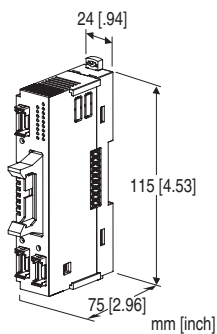

### MODEL: R8-DCM16ALH[1]

#### ORDERING INFORMATION

- Code number: R8-DCM16ALH[1]  
Specify a code from below for [1].  
(e.g. R8-DCM16ALH/Q)
- Specify the specification for option code /Q  
(e.g. /C01)

#### [1] OPTIONS

blank: none

/Q: With options (specify the specification)

#### SPECIFICATIONS OF OPTION: Q

**COATING (For the detail, refer to our web site.)**

/C01: Silicone coating

/C02: Polyurethane coating

#### RELATED PRODUCTS

- PC Configurator cable (model: MCN-CON or COP-US)
  - PC configurator software (model: R8CFG)
- Downloadable at our web site.  
Note: When using with Power/Network module (model: R8-NM1), firmware version Ver1.04 or later is supported.

#### GENERAL SPECIFICATIONS

##### Connection

- **Input:** 4-pin e-CON connector  
Unit side connector XN2D-1474-S002 (Omron)  
Recommended cable side connector XN2A-1470 (Omron)  
Applicable wire size 0.08 - 0.5 mm<sup>2</sup> (AWG28 - 20)  
Outer sheath diameter: max. 1.5 dia  
(The cable side connector is not included in the package. Refer to the specifications of the product.)
- **Output:** 20-pin MIL connector  
Unit side connector XG4A-2034 (Omron)  
Recommended socket XG5N-201 (Omron)  
Recommended contact XG5W-0231 (Omron)  
Applicable wire size AWG22, number of conductor 17, diameter of conductor 0.16 mm  
(The socket and contact are not included in the package. Refer to the specifications of the product.)
- **Excitation supply, internal bus:**  
Connected to internal bus connector
- **Internal power:** Supplied from internal bus connector

**Isolation:** I/O or exc. supply to internal bus or internal power

**Module address:** DIP switches

**Terminating resistor:** Built-in (DIP Switch, default: disable)  
(The others switches depend on operating mode settings)

**Indicator LEDs:** Bi-color (red/green) LED; Refer to the instruction manual.

**Discrete output status indicators:** Green LED; Refer to the instruction manual.

**Interlock status indicators:** Red LED; Refer to the instruction manual.

#### INTERLOCK INPUT SPECIFICATION

**Common:** Negative common (PNP)

**Number of input:** 3 point

**Rated input voltage:** 24 V DC  $\pm 10\%$ ; ripple 5 %p-p max.

**ON voltage / current:**  $\geq 15$  V DC (input - 0V) /  $\geq 2.3$  mA

**OFF voltage / current:**  $\leq 5$  V DC (input - 0V) /  $\leq 1$  mA

**Input current:**  $\leq 4.5$  mA per point at 24 V DC

**Input resistance:** Approx. 5.7 k $\Omega$

**ON delay:**  $\leq 2.0$  msec.

**OFF delay:**  $\leq 2.0$  msec.

The output turns to OFF during interlock is input.

#### OUTPUT SPECIFICATIONS

**Common:** Negative common (NPN) per 16 points

**Maximum outputs applicable at once:** No limit (at 24 V DC)

**Number of output:** 16 points

**Rated load voltage:** 24 V DC  $\pm 10\%$

**Rated output current:** 0.1 A per point, 1.6 A per common

**Residual voltage:**  $\leq 0.5$  V

**Leakage current:**  $\leq 0.1$  mA

**ON delay:**  $\leq 0.5$  msec.

**OFF delay:**  $\leq 1.5$  msec.

With shortcircuit protection

With overheat protection

(When driving an inductive load, connect a diode in parallel with the load.)

## INSTALLATION

**Max. current consumption:** 160 mA

**Operating temperature:** -10 to +55°C (14 to 131°F)

**Operating humidity:** 30 to 90 %RH (non-condensing)

**Atmosphere:** No corrosive gas or heavy dust

**Mounting:** DIN rail

**Weight:** 110 g (0.24 lb)

## PERFORMANCE

**Data allocation:** 1

**Module addresses in use:** 1

**Power output (input connector):** Rated current 50 mA DC per channel

**Power output (output connector):** Rated current 3 A DC (rated current 3 A for internal fuse (slow blow fuse  $i^2t$  ( $A^2sec.$ ) max. 5.04)

**Insulation resistance:**  $\geq 100$  M $\Omega$  with 500 V DC

**Dielectric strength:** 1500 V AC @ 1 minute (I/O or exc. supply to internal bus or internal power to ground)

## STANDARDS & APPROVALS

**EU conformity:**

EMC Directive

EMI EN 61000-6-4

EMS EN 61000-6-2

RoHS Directive

## EXTERNAL VIEW

### LEFT SIDE VIEW

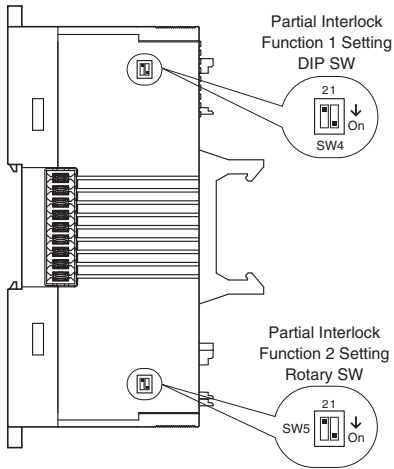

### FRONT VIEW

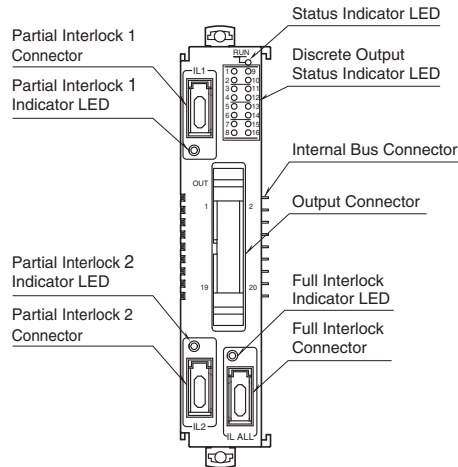

### RIGHT SIDE VIEW

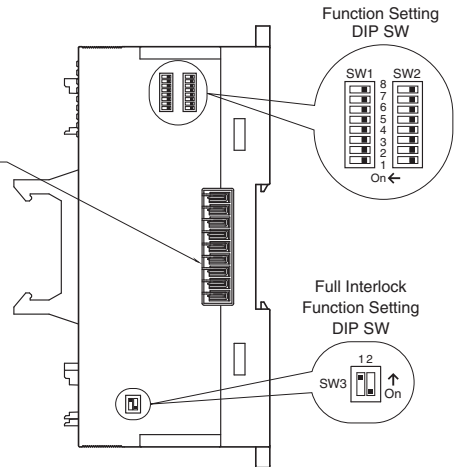

## OPERATING MODE SETTING

(\*) Factory default setting

Note: Be sure to set unused SW2-2 through 2-4, 2-7, SW3-2, SW4-2 and SW5-2 to OFF.

### ■ MODULE ADDRESS (SW1)

SW1-1 through 1-4 determine the tenth place digit, while SW1-5 through 1-8 do the ones place digit of the module address.

Address is selected between 0 to 31.

(Factory setting: 0)

MODULE ADDRESS	SW1				
	×10	1	2	3	4
	×1	5	6	7	8
0		OFF	OFF	OFF	OFF
1		OFF	OFF	OFF	ON
2		OFF	OFF	ON	OFF
3		OFF	OFF	ON	ON
4		OFF	ON	OFF	OFF
5		OFF	ON	OFF	ON
6		OFF	ON	ON	OFF
7		OFF	ON	ON	ON
8		ON	OFF	OFF	OFF
9		ON	OFF	OFF	ON

### ■ INTERLOCK COMMUNICATION LOGIC REVERSAL (SW2)

Setting internal communication bus logic.

INTERLOCK COMMUNICATION LOGIC REVERSAL	SW2-1
Interlock function setting off: 1 Interlock function setting on: normal = 1, interlock = 0	ON
Interlock function setting off: 0 (*) Interlock function setting on: normal = 0, interlock = 1	OFF

Note: 1 and 0 values are validated as logic through internal communication bus logic.

### ■ OUTPUT AT THE LOSS OF COMMUNICATION (SW2)

Same output for all channels.

OUTPUT AT THE LOSS OF COMMUNICATION	SW2-5
Output Hold (*) (last data correctly received is hold)	OFF
Stop output (output fixed at OFF)	ON

### ■ TERMINATOR (SW2)

TERMINATOR	SW2-6
Without (*)	OFF
With	ON

### ■ CONFIGURATION MODE (SW2)

CONFIGURATION MODE	SW2-8
DIP switch setting (*)	OFF
PC Configurator and communication	ON

### ■ FULL INTERLOCK FUNCTION (SW3)

It is available to apply full interlock function to all outputs (Do1 through Do16)

FULL INTERLOCK FUNCTION	SW3-1
OFF	OFF
ON (*) (all outputs OFF if input OFF)	ON

### ■ PARTIAL INTERLOCK (SW4, 5)

#### • Partial Interlock Function 1

At output, it is available to apply interlock function to Do1 through Do8.

PARTIAL INTERLOCK FUNCTION 1	SW4-1
OFF	OFF
ON (*) (Input OFF with output OFF)	ON

#### • Partial Interlock Function 2

At output, it is available to apply interlock function to Do9 through Do16.

PARTIAL INTERLOCK FUNCTION 2	SW5-1
OFF	OFF
ON (*) (Input OFF with output OFF)	ON

**EXTERNAL DIMENSIONS unit: mm [inch]**

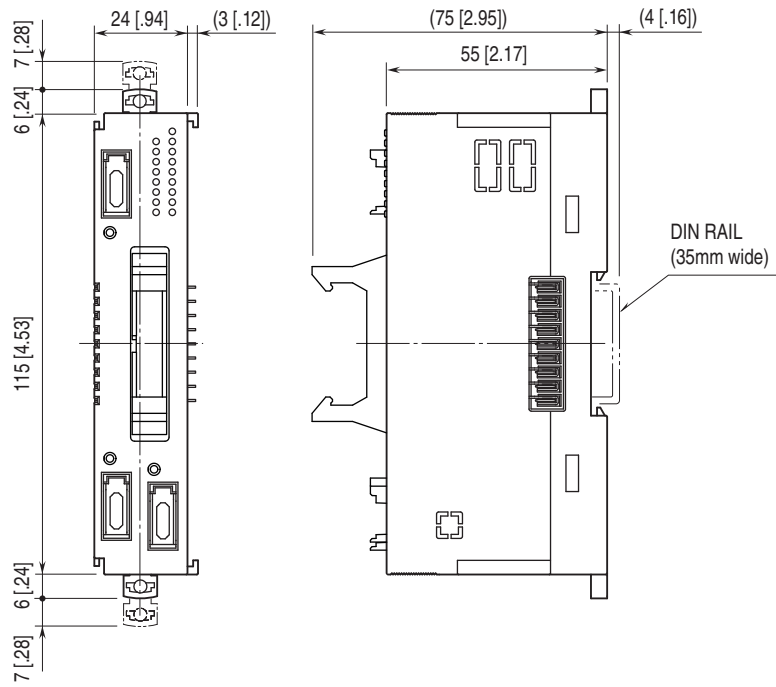

**SCHEMATIC CIRCUITRY & CONNECTION DIAGRAM**

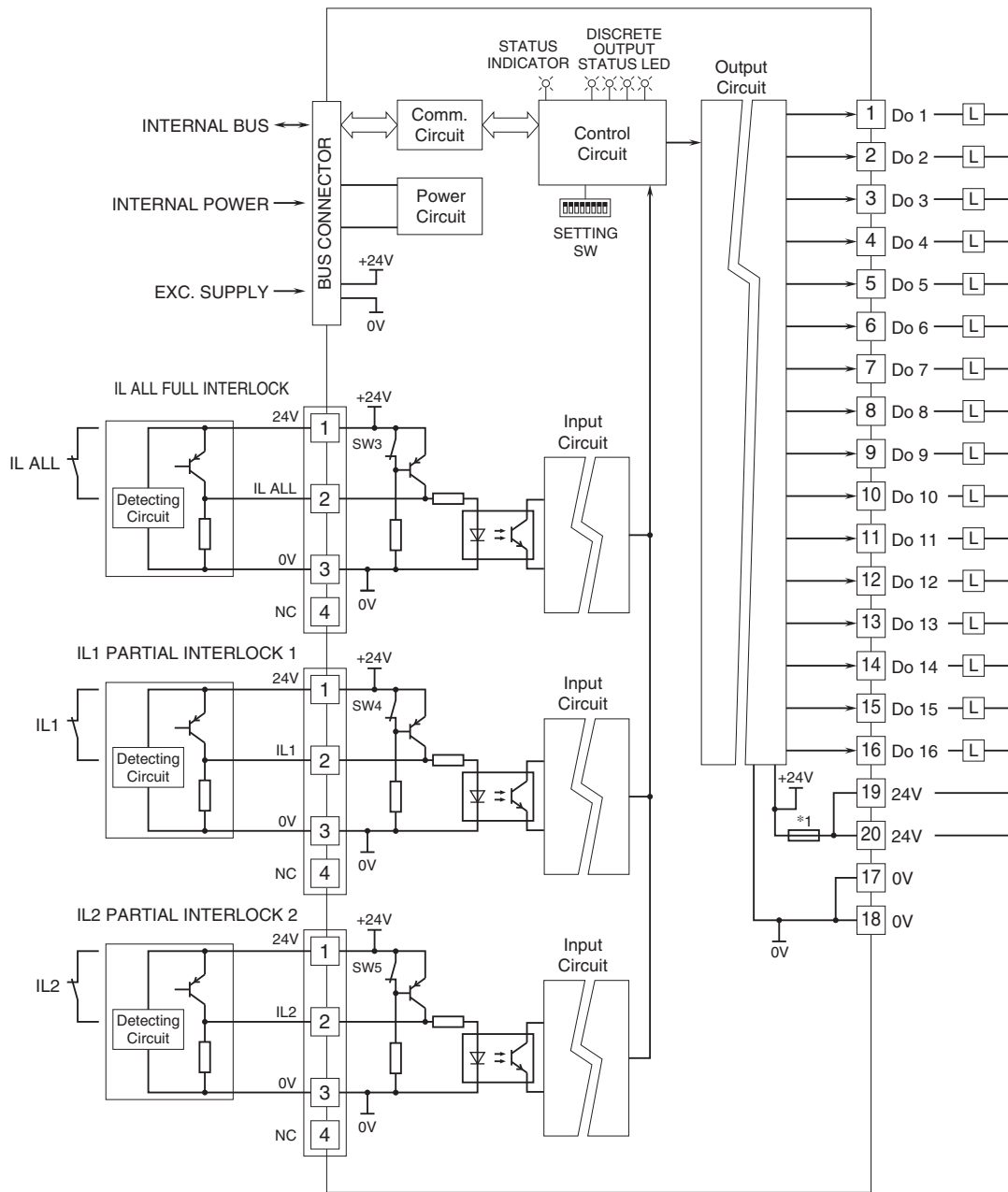

\*1. Fuse is not replaceable.

## ■ OUTPUT CIRCUIT

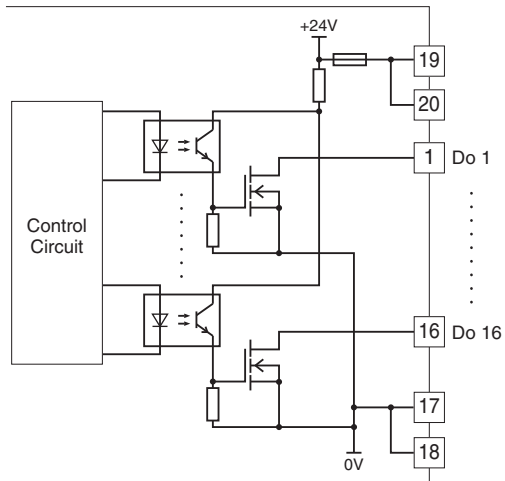

Specifications are subject to change without notice.