

<h1>外形図</h1>	<h2>ST/STL</h2> <h3>ソフトターミナル</h3>	<h2>共通機器</h2>
--------------	-----------------------------------	---------------

特記事項

外形寸法図 (単位: mm)

■ST

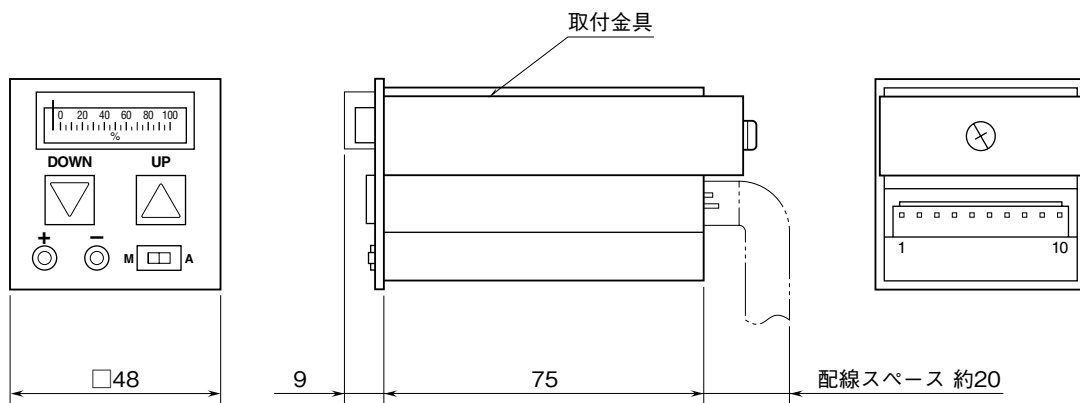

■STL

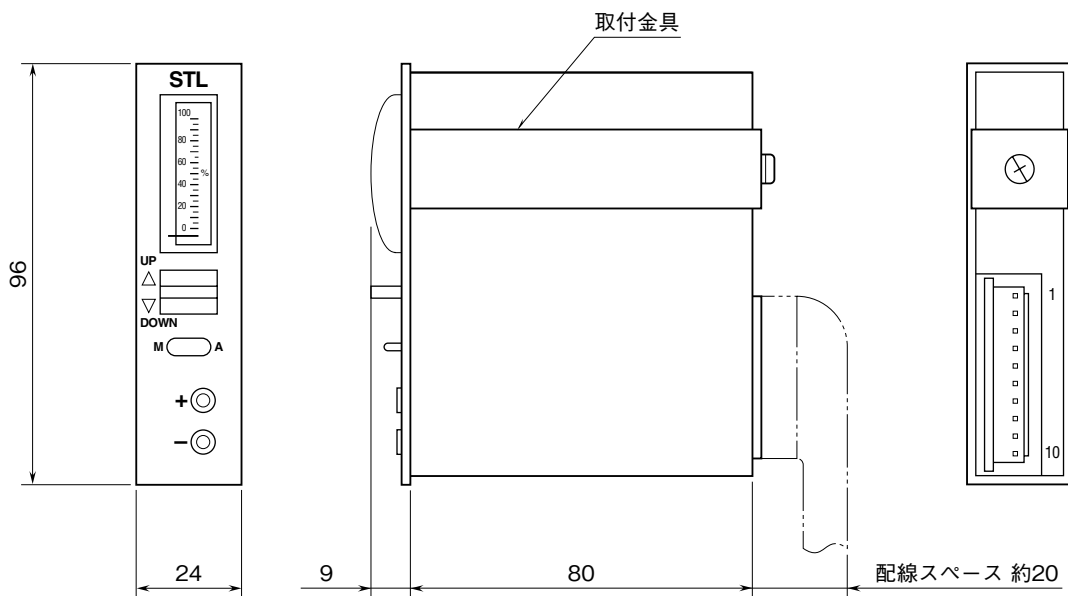

●コネクタ付ケーブル

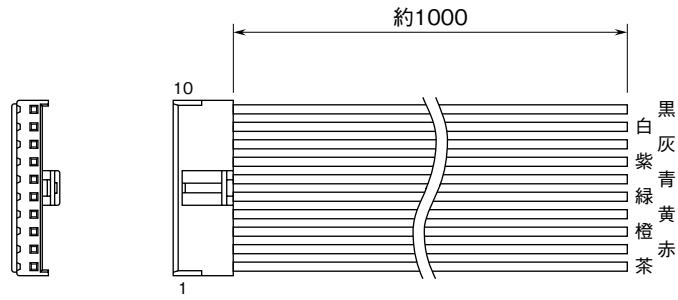

※、端末は切り落としです。

端子接続図

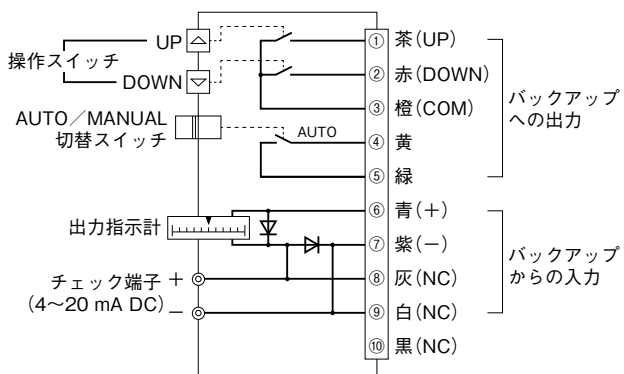

取付寸法図 (単位: mm)

■パネルカット寸法図

取付板厚: 0.5 ~ 6

●ST

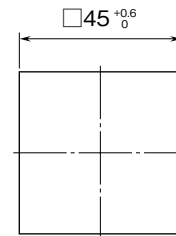

●STL

